

**MERITOR®  
TRAILER WHEEL END &  
SUSPENSION PARTS CATALOGUE**



**MERITOR®**



**ALLFIT**



# IMPORTANT INFORMATION

## AFTERMARKET PARTS WARRANTY

We warrant all new parts for one year from date of shipment to the buyer against defective material or workmanship (but not against damage caused by accident, abuse or improper installation, maintenance or repair) when such parts are used on vehicles the specifications of which have been approved by our Engineering Department.

As the exclusive remedy under this warranty, we will, at our option, repair or replace such parts free of charge, or take back the nonconforming parts and refund the monies paid by buyer for such parts, if found on examination by us to be nonconforming and if necessary return charges are prepaid.

If it is necessary to return any parts under this warranty, buyer agrees not to make any deduction on account thereof from remittances on current accounts while claims are in the process of disposition. Any expense incurred without our consent for repairs or replacement will not be allowed.

THIS WARRANTY IS EXPRESSLY IN LIEU OF ALL OTHER WARRANTIES OR CONDITIONS, EXPRESS, IMPLIED OR STATUTORY, INCLUDING ANY IMPLIED WARRANTY OF MERCHANTABILITY OR FITNESS FOR PARTICULAR PURPOSE. IN NO EVENT SHALL SELLER BE LIABLE FOR INCIDENTAL OR CONSEQUENTIAL DAMAGES OF ANY NATURE.

Only genuine Meritor replacement parts are covered by this aftermarket parts warranty.

## DISCLAIMER

Information contained in this publication is in effect at the time the publication was approved for printing and is subject to change without notice or liability. Meritor, reserves the right to revise the information presented or discontinue the production of parts described at any time.

Manufacturers names, part numbers, symbols or other references appearing in this catalogue are used for reference for order of goods only. Images are also for reference only and not to scale.

## TRADEMARK

The designated trademarks are registered marks of their respective owners and Meritor and its affiliates are not commercially connected, affiliated, or associated with any of the owners of such marks. The Meritor products presented herein are not endorsed or authorised by any of the trademark owners.

## COPYRIGHT

All rights reserved. The Meritor and Euclid logo(s) or any part or layout of the catalogue cannot be printed or reproduced without written authorisation from Meritor.



### Found an error?

If you detect any errors in this catalogue, please let us know. We want to ensure the information we publish is as accurate as possible. We appreciate your help in making this happen.

Please forward your enquiries to:

**Email:** [meritoraftermarketau@meritor.com](mailto:meritoraftermarketau@meritor.com)

**Phone:** (03) 8353 6050



# TABLE OF CONTENTS

## AXLE WHEEL END PARTS

### DANA SPICER

D21/D22 & K21/K22 Axles - 16-1/2" x 7" brakes .....	4-9
Standard Forge Early Axle - 12-1/4" x 7 1/2" brakes (Cast Shoes) .....	10-13
Standard Forge Late Axle - 12-1/4" x 7 1/2" brakes (Fabricated Shoes) .....	14-17

### EATON

JE 501 - 16 1/2" x 7" brakes .....	18-21
E34 - 15" Axle - 12-1/4" x 7-1/2" brakes .....	22-23
541 Series Brakes - 16-1/2" brakes .....	24-25
"ES" Extended Service Brakes - 16-1/2" brakes .....	26-27
"ESII" Extended Service Brakes - 16-1/2" brakes .....	28-29

### FREIGHTER

Standard Forge Late Axle - 12-1/4" x 7 1/2" brake (Fabricated Shoes) .....	14-17
MKV - 16-1/2" X 7" brakes .....	30-33
Ingersoll (IMT) - A22H / F22H Axle 16-1/2" X 7" brakes .....	34-37

### FRUEHAUF

Round & I Beam Axle - 16-1/2" x 7" brakes .....	38-41
Propar Axle - 16-1/2" x 7" brakes .....	42-45
Propar Axle - 12-1/4" x 8" brakes .....	46-49

### HENDRICKSON

Intraax Trailer Axle - 16-1/2" X 7 / 16-1/2" X 8-5/8" brakes .....	50-53
--	-------

### HOLLAND

P Series Trailer Axle - Propar Parralel Bearings - 16-1/2" x 7" brakes .....	54-57
T Series Trailer Axle - Tapered Bearings - 16-1/2" x 7" brakes .....	58-61

### MERITOR

Rockwell - ARN/ATN (10 Spline), 4000/6000 (28 Spline) .....	62-67
Rockwell - RN / TN Axle - 16-1/2" x 7" brakes .....	68-73
TN/TQ Axle - Fabricated Brake Spider - 16-1/2" x 7" brakes .....	74-79
TN Metric Axle - Cast Brake Spider/Stepped Camshafts (to June 1991) - 16-1/2" x 7" brakes .....	80-83
TM Metric Axle - Cast Brake Spider/Stepped Camshafts (from June 1991) - 16-1/2" x 7" brakes .....	84-87
16 1/2" diameter - "Q" & "P" brakes .....	88-91
15" & 16 1/2" diameter - "Q" PLUS Brakes Steering & Drive Axles .....	92-95
15" diameter "Q" Series - Steer Axle Brake .....	96-97
"T" Series - 15" diameter Brakes - Steer Axle Brake WITH 1 1/4" & 1 1/2" diameter Camshaft .....	98-99
Rockwell - Stopmaster 12° Wedge Brakes, 15" x 3" Brake - Steer Axle (Backing Plate Mounted Dual Act.) .....	100
Rockwell - Stopmaster 12° Wedge Brakes, 15" x 7" Brake - Drive & Trailer Axle (Brake Spider Mount) .....	101



# TABLE OF CONTENTS

## AIR SUSPENSION PARTS

### AIRGLIDE

100 Air Glide Suspension .....	102-103
200 Air Suspension .....	104

### FAS II

Air Ride Suspension .....	105
---------------------------	-----

### HENDRICKSON

Intraax Air Suspension -AA230T/AA250T .....	106-107
Air Suspension - HA Series .....	108
Air Suspension - HAS Series .....	109
Air Suspension - HT190U/HT230/HT250 Series .....	110-111
Air Suspension - T15/T17/HT300 .....	112-113
Auxiliary Air Suspension -HLM/HLM-1/HLM-1-TR .....	114-115

### MERITOR

CS9i - Top/Low Mount Air Suspension .....	116-117
ROR FlexAir Suspension - FL9000 .....	118-119
ROR FlexAir Suspension - FL9000L .....	120-121
ROR FlexAir Suspension - FL9000M .....	122-123
ROR FlexAir Suspension - FL11000/FL11000L .....	124-125

### NEWAY

Suspension -ARDST/ARDSTM&L Series, Models -123-6, -244-6, -246-6 .....	126-127
Suspension -AD-123/246 -6.5, -8.75, -10 Series .....	128-129

## MECHANICAL SUSPENSION PARTS

### FRUEHAUF

'F' Type Overlsung .....	130-131
F-2 Suspension .....	132-133

### HENDRICKSON

HN-402/462 .....	134-135
------------------	---------

### REYCO

21B .....	136-137
102W .....	138
Transpro .....	139

### VOLVO

"T-Ride" Suspension .....	140-141
---------------------------	---------



# TABLE OF CONTENTS

## ACCESSORIES

Cam Spring Brakes .....	142
Coiled Air Hoses .....	142
Gladhands .....	142
Air Brake Service Tools .....	142
Brake Shoe Anchor Pin Press .....	143
Wheel Bearing Lock-Nut Wrench .....	143
Suspension Service Tools .....	144
Front End Service Tools .....	144
Truck Wheel Bearing Lock-Nut Assortments .....	145

## ADDITIONAL INFORMATION

Meritor Brake Shoe Kits .....	146
Euclid Brake Shoe Kits .....	147
Steellite X30 Brake Drums .....	148
U-Bolt .....	149
Uni Rod Kits .....	149-150
Wheel Bearing Sets .....	151
Wheel Bearings (Individual) .....	151
Wheel Bearing Kits .....	152-153
Wheel Seals .....	153

## PARTS CROSS REFERENCE

Meritor to Competitor Parts Cross Reference .....	154-161
---	---------



# DANA SPICER

D21, D22 AND K21, K22 AXLES  
16-1/2" x 7" BRAKES

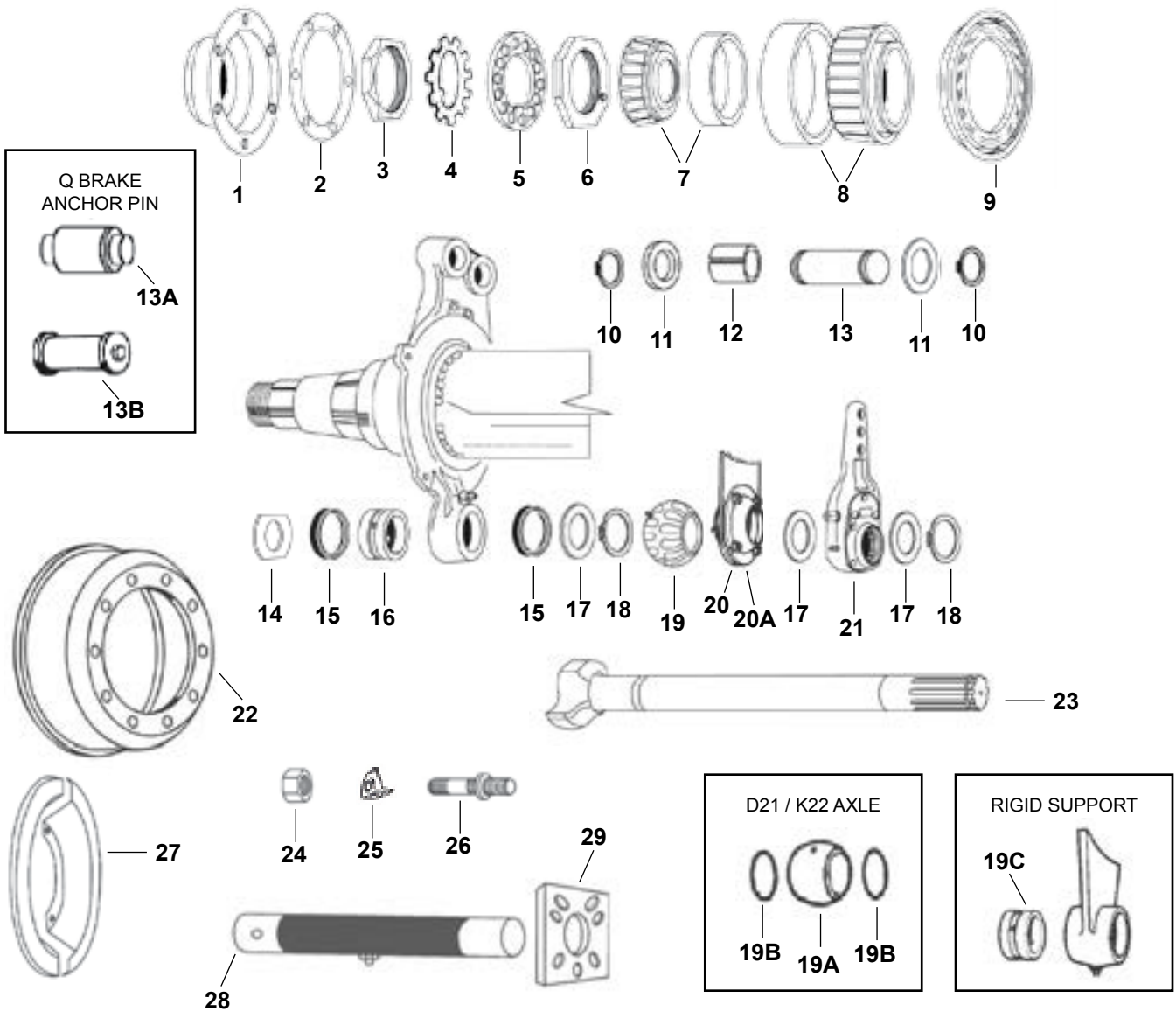

## "Q" TYPE BRAKE

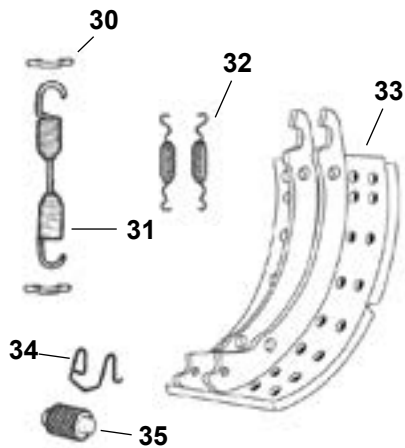

## "P" TYPE BRAKE

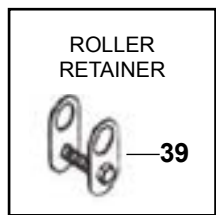
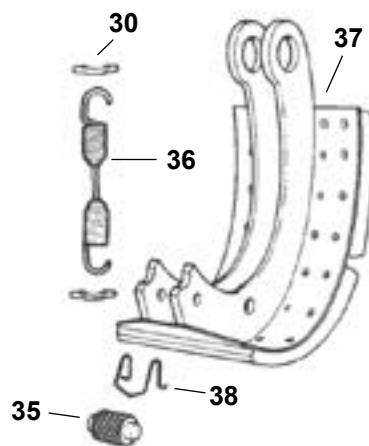

# DANA SPICER

## D21, D22 AND K21, K22 AXLES 16-1/2" x 7" BRAKES

ITEM NUMBER	PART NUMBER	DESCRIPTION
1	E-975	HUB CAP - GREASE
2	E-03009	HUB CAP GASKET - MULTI DRILLED 3, 5, 6 HOLE
3	E-572	OUTER AXLE SPINDLE NUT
4	E-2237	LOCK TAB WASHER
5	E-573	LOCK WASHER
6	E-540	INNER AXLE SPINDLE NUT
7	MERSET413	OUTER BEARING SET (HM212049/HM212011)
8	MERSET405	INNER BEARING SET - D21/K21 (663/653)
8	MERSET414	INNER BRG SET D22/K22 (HM218248/HM218210)
9	MER0113	HUB SEAL D21/K21
9	MER0143	HUB SEAL D22/K22
10	1229X1116	CIRCLIP - TO SUIT 1-1/4" SHAFT
11	E-1113	WASHER - 1-7/8" OD X 1-1/4" ID X 1/16"
12	E-1893	ANCHOR PIN BUSH - STAINLESS STEEL
12	1225B496	ANCHOR PIN BUSH BRONZE LINED
13	1259M1131	ANCHOR PIN - STANDARD (CIRCLIP TYPE)
13A	1259N274	Q' BRAKE ANCHOR PIN
13B	-	BOLT ON ANCHOR PIN LONG (NOT SOLD SEPARATELY - PART OF KIT E-8465AU)
14	E-656	D' WASHER
15	E-1416	SEAL
16	E-759	OUTER CAM BUSH - NYLON
17	E-580	WASHER - 2.25" OD X 1.53" ID X 0.06" THICKNESS
18	1229Z1118	CIRCLIP
19	E-2102	BUSH (D22 - K22)
19A	E-2517	BUSH (D21 + K21)
19B	E-1314	'O' RING (D21 + K21)
19C	E-661	INNER CAM BUSH - OLD STYLE WITH RIGID BRACKET
20	E-2104	CAM BUSH & BRACKET ASSEMBLY
20A	E-2365	RETAINER PLATE
21	E-612S-BK	SLACK ADJUSTER - 3 HOLE X 10 SPLINE
22	03-122222-002	BRAKE DRUM 11" PCD 9.44" SPIGOT 5 & 6 BOLT HOLES
23	E-1425A	S' CAM LH 10 SPLINE - PLEASE CONTACT CUSTOMER SERVICE FOR ALTERNATES
23	E-1424A	S' CAM RH 10 SPLINE - PLEASE CONTACT CUSTOMER SERVICE FOR ALTERNATES
24	E-7775	WHEEL NUT
25	E-5571A	WHEEL CLAMP (FOR 5/6 SPOKE HUBS ONLY)

[More Parts Next Page](#)



# DANA SPICER

D21, D22 AND K21, K22 AXLES  
16-1/2" x 7" BRAKES

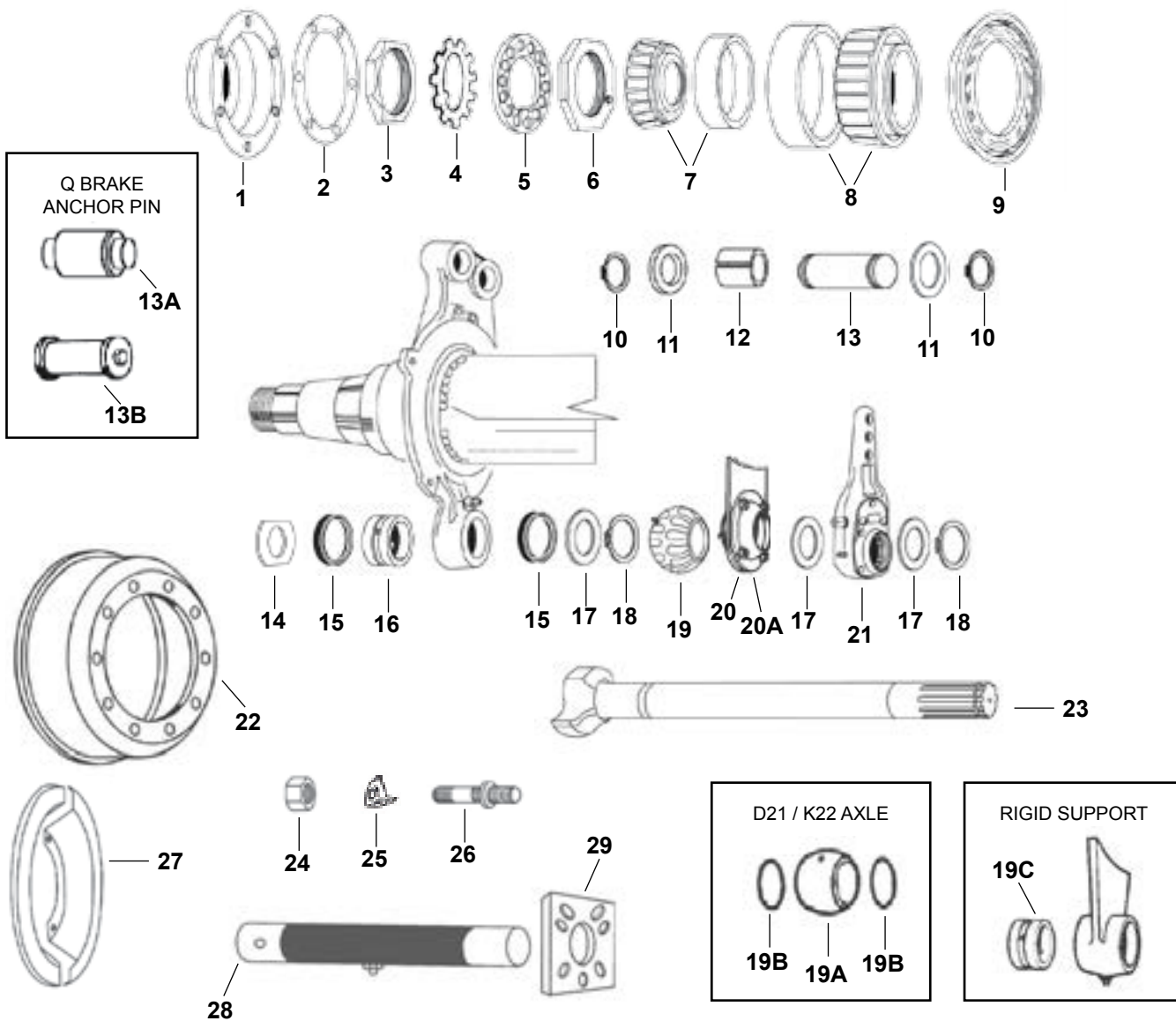

## "Q" TYPE BRAKE

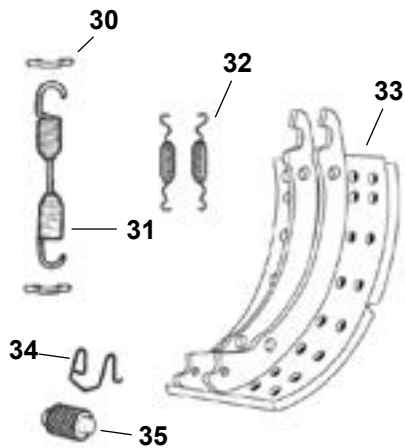

## "P" TYPE BRAKE

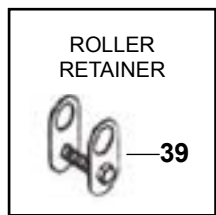
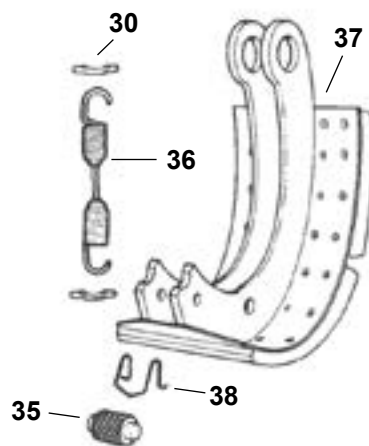



# DANA SPICER

## D21, D22 AND K21, K22 AXLES 16-1/2" x 7" BRAKES

ITEM NUMBER	PART NUMBER	DESCRIPTION
26	R004956A	WHEEL STUD
27	E-886	BACKING PLATE (STEEL)
27	E-3775	BACKING PLATE (PLASTIC)
28	E-4737A	CAM ENCLOSURE
29	E-4739	CAM ENCLOSURE PLATE
30	E-747	SPRING RETAINING PIN
31	2258W803	RETURN SPRING - 'Q' BRAKE
32	E-2767	RETAINING SPRING - 'Q' BRAKE
33	SMG2A4515Q	LINED BRAKE SHOE (NOT SOLD SEPARATELY - PART OF KITS KSMA2124515Q & EKSMG2A4515Q)
34	3105B210	ROLLER RETAININER - 'Q' BRAKE
35	2297T7222	ROLLER - SMOOTH
35	E-2177	ROLLER - KNURLED
35	E-2215	ROLLER - KNURLED 1/8" OVERSIZE
35	E-781	ROLLER - SMOOTH 1/8" OVERSIZE
35	E-586	ROLLER - SMOOTH 1/4" OVERSIZE
36	E-1880B	RETURN SPRING - P-BRAKE
37	SMA2124515P	LINED BRAKE SHOE (NOT SOLD SEPARATELY - PART OF KIT PKSMA2124515P)
37	SMG2A4515PHD	LINED BRAKE SHOE (NOT SOLD SEPARATELY - PART OF KIT EKSMG2A4515PHD)
38	E-539	ROLLER RETAINER - P-BRAKE
39	-	CAM ROLLER RETAINER KIT. (NOT SOLD SEPARATELY - PART OF KIT E-8465AU)

[More Parts Next Page](#)



# DANA SPICER

D21, D22 AND K21, K22 AXLES  
16-1/2" x 7" BRAKES

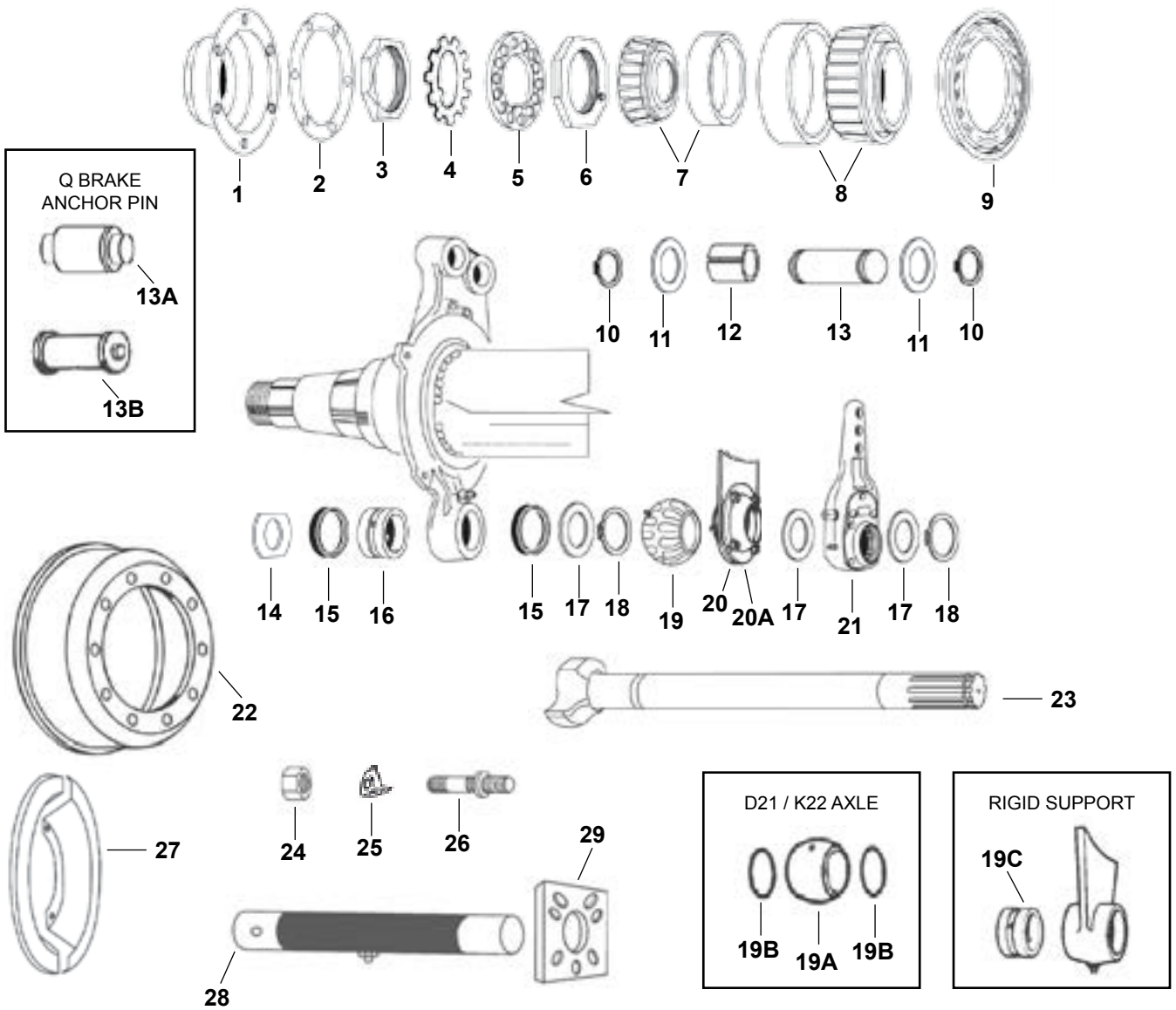

## "Q" TYPE BRAKE

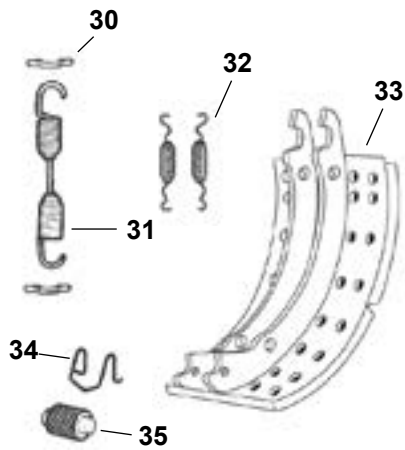

## "P" TYPE BRAKE

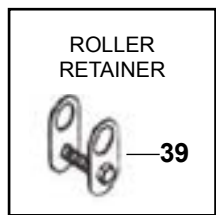
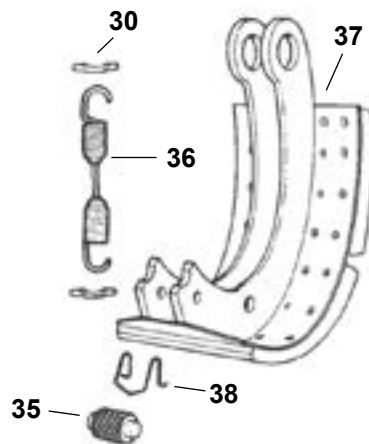

# DANA SPICER

D21, D22 AND K21, K22 AXLES  
16-1/2" x 7" BRAKES

ITEM NUMBER	PART NUMBER	DESCRIPTION
KIT	E-8466AU	HARDWARE KIT 'P' BRAKE FOR SHOES WITH WELDED WASHERS (KNURLED ROLLERS). SERVICES 1 WHEEL
KIT	E-8465AU	HARDWARE KIT 'P' BRAKE FOR SHOES WITH WELDED WASHERS (SMOOTH ROLLERS). SERVICES 1 WHEEL
KIT	KIT9000**	HARDWARE KIT 'P' BRAKE - SERVICES 1 WHEEL.
KIT	E-1816SHD	HARDWARE KIT 'P' BRAKE - SERVICES 1 WHEEL.
KIT	KIT8000HD**	HARDWARE KIT 'Q' BRAKE. INCLUDES ENOUGH COMPONENTS TO SERVICE 1 WHEEL.
KIT	E-2769HD	HARDWARE KIT 'Q' BRAKE. INCLUDES ENOUGH COMPONENTS TO SERVICE 1 WHEEL.
KIT	R615008	CAMSHAFT BUSH KIT. CAMSHAFT REPAIR KIT SERVICE 1 AXLE.
KIT	E-2287	CAMSHAFT BUSH KIT. CAMSHAFT REPAIR KIT SERVICE 1 AXLE.
KIT	KSMA2124515Q**	4515-Q MAJOR BRAKE SHOE KIT - CONSISTS OF 2 LINED SHOES & HARDWAREKIT - SERVICES 1 WHEEL.
KIT	EKSMG2A4515Q*	4515-Q MAJOR BRAKE SHOE KIT - CONSISTS OF 2 LINED SHOES & HARDWARE KIT - SERVICES 1 WHEEL.
KIT	PKSMA2124515P**	4515-P MAJOR BRAKE SHOE KIT - CONSISTS OF 2 LINED SHOES & HARDWARE KIT - SERVICES 1 WHEEL.
KIT	EKSMG2A4515PHD*	4515-P MAJOR BRAKE SHOE KIT - CONSISTS OF 2 LINED SHOES & HARDWARE KIT - SERVICES 1 WHEEL.
KIT	PKSMA2124515PSS**	4515-P (WITH WELDED WASHER) MAJOR BRAKE SHOE KIT - CONSISTS OF 2 LINED SHOES & HARDWARE KIT - SERVICES 1 WHEEL.
KIT	EKSMG2A4515PSS*	4515-P (WITH WELDED WASHER) MAJOR BRAKE SHOE KIT - CONSISTS OF 2 LINED SHOES & HARDWARE KIT - SERVICES 1 WHEEL.

\* Please contact Customer Service for details on other grades of friction material available.

\*\* Restricted sale.



# DANA SPICER

## STANDARD FORGE EARLY AXLE 12-1/4" x 7 1/2" BRAKES (CAST SHOES)

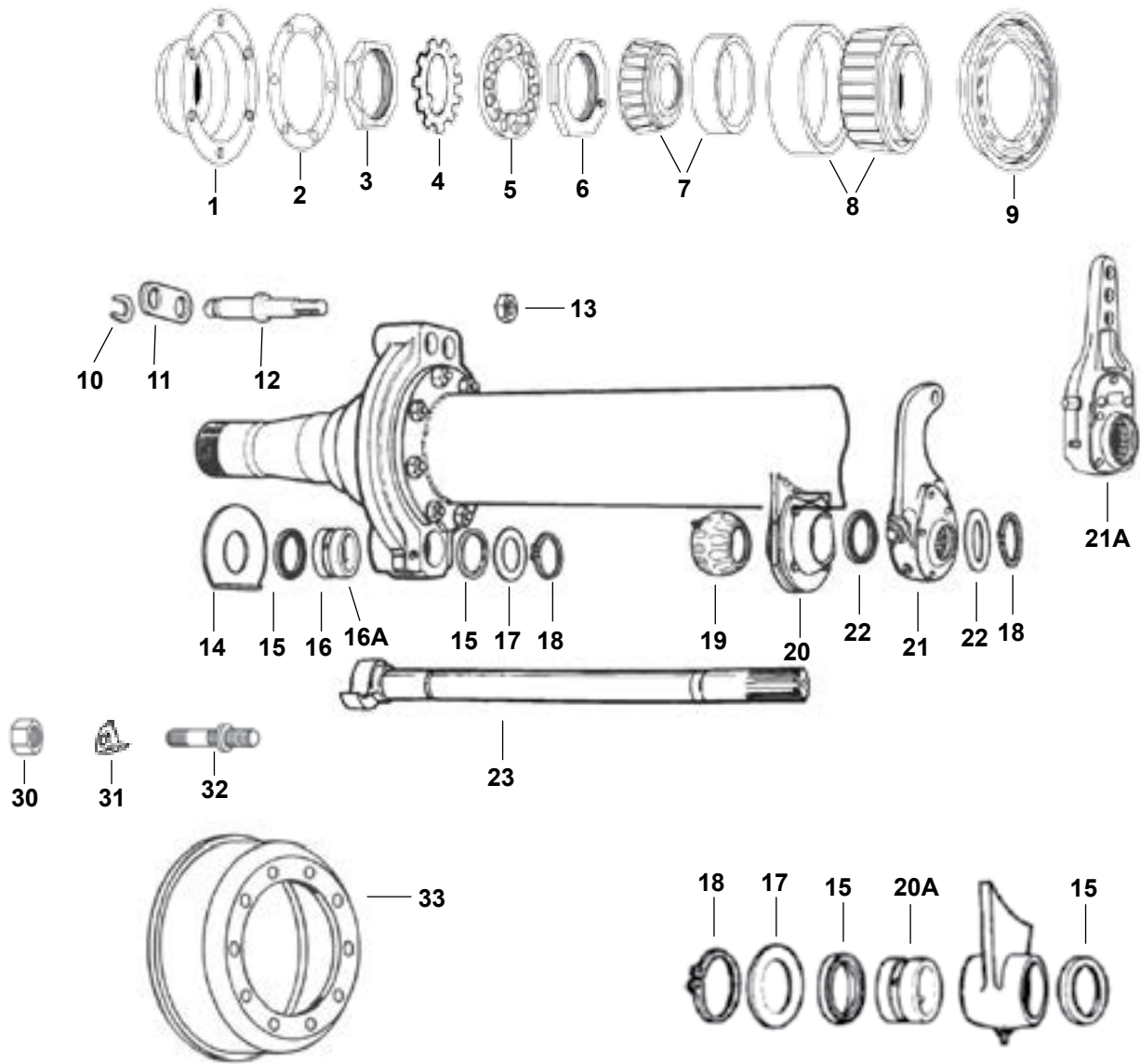

EARLY MODEL

LATE MODEL

OLD STYLE

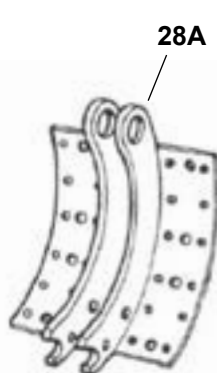
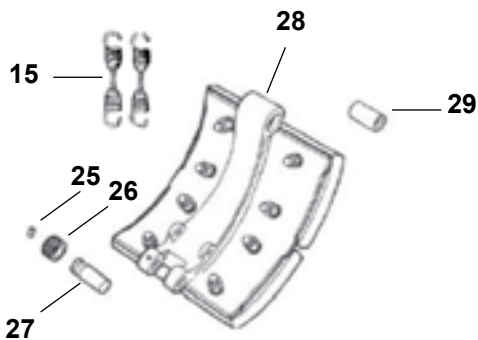

USE WITH H/W KIT  
E-3374HD  
FMSI: 4692

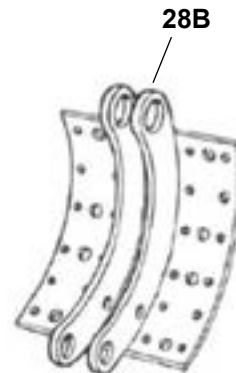

USE WITH H/W KIT  
E-2403  
FMSI: 4591

# DANA SPICER

## STANDARD FORGE EARLY AXLE 12-1/4" X 7 1/2" BRAKES (CAST SHOES)

ITEM NUMBER	PART NUMBER	DESCRIPTION
1	E-975	HUB CAP - GREASE
2	E-03009	HUB CAP GASKET - MULTI DRILLED 3, 5 & 6 HOLE
3	E-572	OUTER AXLE SPINDLE NUT
4	E-2237	LOCK TAB WASHER
5	E-573	LOCK WASHER GP AXLE
6	E-540	INNER AXLE SPINDLE NUT
7	MERSET413	OUTER BEARING SET (HM212011/HM212049)
8	MERSET405	INNER BEARING SET (663/653)
9	MER0113	HUB SEAL
10	E-1106	'C' CLIP
11	E-2401	PLATE
12	E-2029	ANCHOR PIN
13	E-1107	LOCK NUT 3/4" X 16 THD
14	E-1408	WASHER
15	E-1416	SEAL
16	E-759	OUTER CAM BUSH - NYLON
16A	E-807	OUTER CAM BUSH - BRONZE
17	E-2409	CAMSHAFT SPACER WASHER
18	1229Z1118	CIRCLIP
19	E-2102	INNER CAM BUSH
20	E-2365	RETAINER PLATE
20A	1225L1208	INNER CAM BUSH FOR RIGID SUPPORT ONLY
21	E-2091	SLACK ADJUSTER - 1 HOLE CURVED, 10 SPLINE
21A	E-612S-BK	SLACK ADJUSTER - 3 HOLE, 10 SPLINE
22	E-2409	CAMSHAFT SPACER WASHER
23	E-1411	'S' CAM LH - CALL CUSTOMER SERVICE FOR ALTERNATES
23	E-1410	'S' CAM RH - CALL CUSTOMER SERVICE FOR ALTERNATES
24	E-2101	RETURN SPRING
25	E-773	GRUB SCREW
26	E-500	SMOOTH ROLLER
26	E-2176	KNURLED ROLLER
27	E-501	ROLLER PIN

[More Parts Next Page](#) 



# DANA SPICER

## STANDARD FORGE EARLY AXLE 12-1/4" x 7 1/2" BRAKES (CAST SHOES)

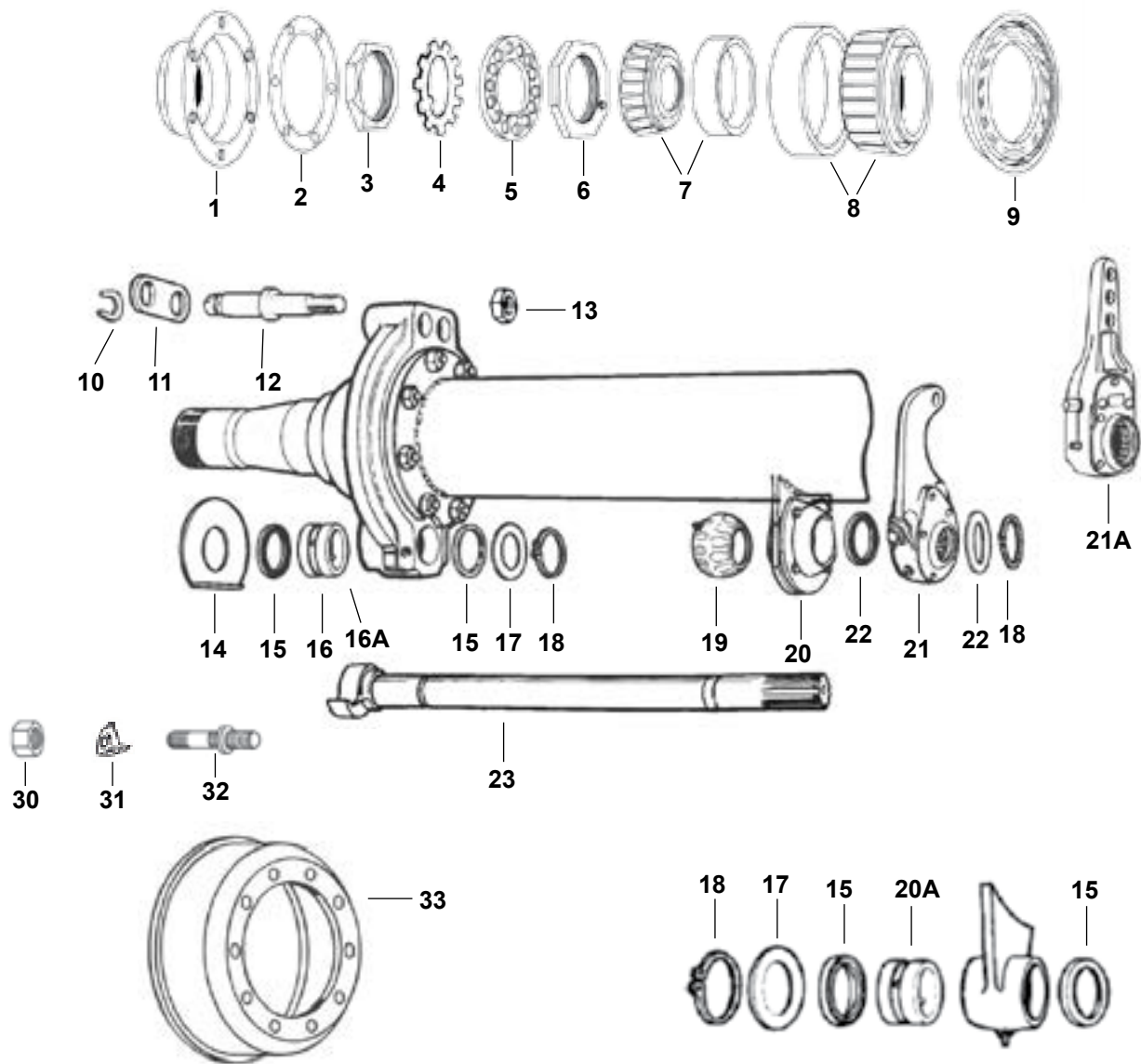

EARLY MODEL

LATE MODEL

OLD STYLE

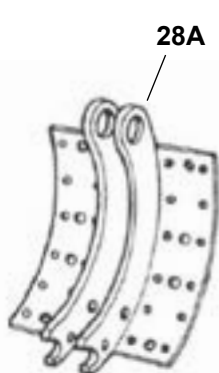
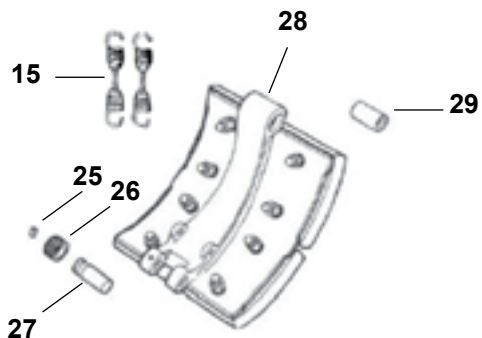

USE WITH H/W KIT  
E-3374HD  
FMSI: 4692

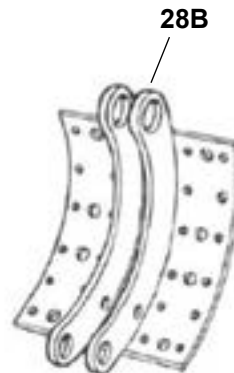

USE WITH H/W KIT  
E-2403  
FMSI: 4591

# DANA SPICER

## STANDARD FORGE EARLY AXLE 12-1/4" X 7 1/2" BRAKES (CAST SHOES)

ITEM NUMBER	PART NUMBER	DESCRIPTION
28	-	CAST BRAKE SHOE
28A	-	LINED BRAKE SHOE (NOT SOLD SEPARATELY - PART OF KIT KSMA2124692FC2)
28A	-	LINED BRAKE SHOE (NOT SOLD SEPARATELY - PART OF KIT EKSMG2A4692)
28B	-	LINED BRAKE SHOE (NOT SOLD SEPARATELY - PART OF KIT KMG14591S)
29	E-1808	BUSH
30	E-7775	WHEEL NUT
31	E-5571A	WHEEL CLAMP (FOR 5/6 SPOKE HUBS ONLY)
32	R004956A	STUD
33	03-122963-002	BRAKE DRUM - 8-1/2" SPIGOT / 10" PCD

KIT	E-3374HD	HARDWARE KIT - CONVERTS CAST SHOES TO FABRICATED SHOES (FMSI: 4692). SERVICES 1 WHEEL.
KIT	E-2403HD	HARDWARE KIT - CONVERTS CAST SHOES TO FABRICATED SHOES (FMSI: 4591). SERVICES 1 WHEEL.
KIT	E-2030HD	HARDWARE KIT FOR MINOR REPAIR FOR CAST SHOES. SERVICES 1 WHEEL
KIT	KSMA2124692FC2**	4692 MAJOR BRAKE SHOE KIT - CONSISTS OF 2 LINED SHOES & HARDWARE KIT - SERVICES 1 WHEEL.
KIT	EKSMG2A4692*	4692 MAJOR BRAKE SHOE KIT - CONSISTS OF 2 LINED SHOES & HARDWARE KIT - SERVICES 1 WHEEL.
KIT	KMG14591S	4591 MAJOR BRAKE SHOE KIT - CONSISTS OF 2 LINED SHOES & HARDWARE KIT - SERVICES 1 WHEEL.

\* Please contact Customer Service for details on other grades of friction material available.

\*\* Restricted sale.



# FREIGHTER A19H & F22H / DANA SPICER STANDARD FORGE LATE AXLE

12-1/4" x 7 1/2 BRAKE (FABRICATED SHOE)

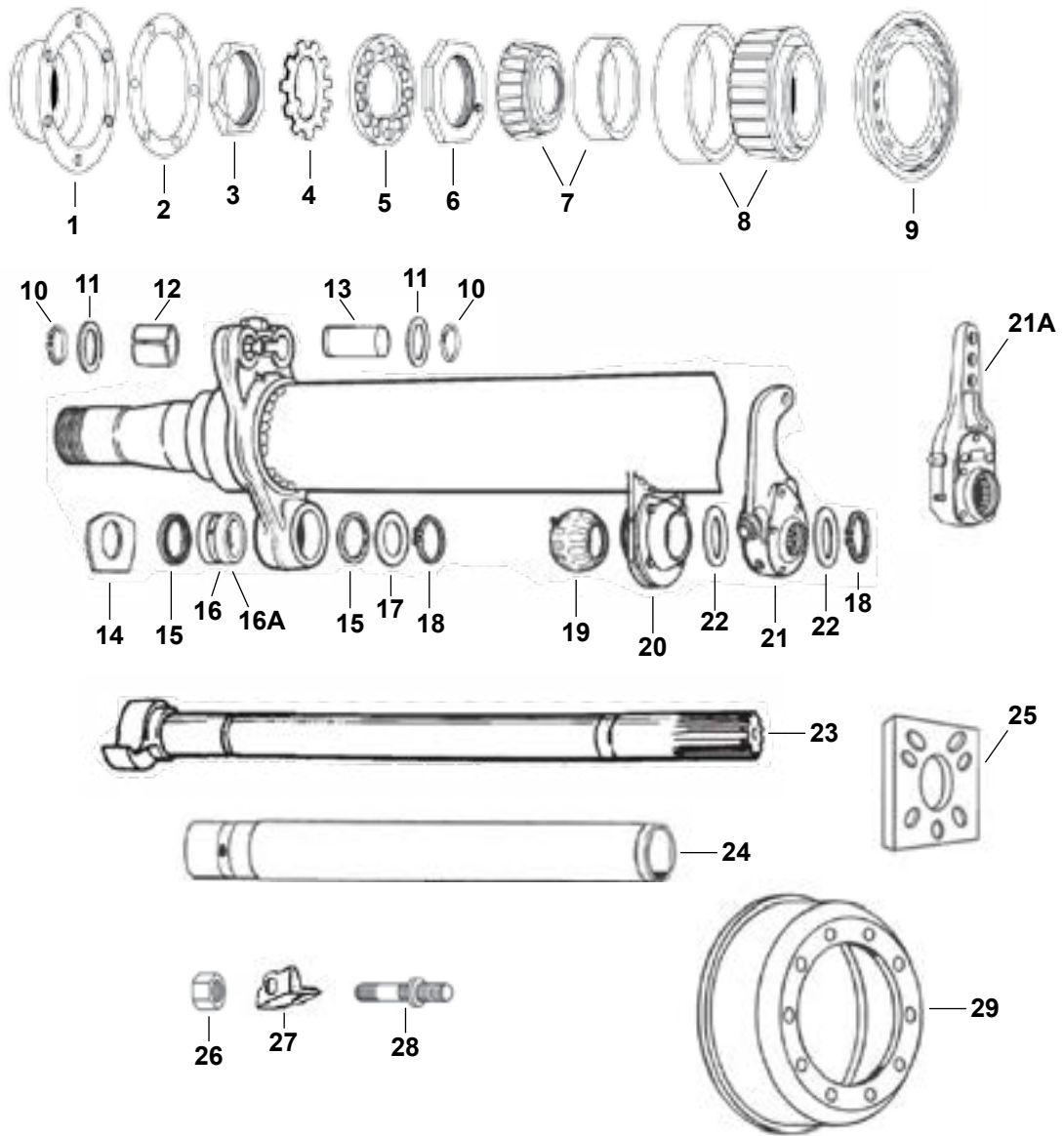

## EARLY BRAKE SHOE

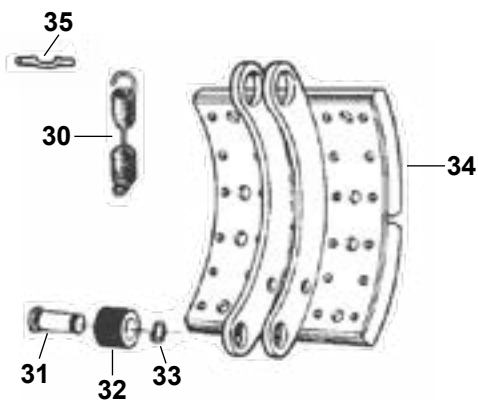

## LATE BRAKE SHOE

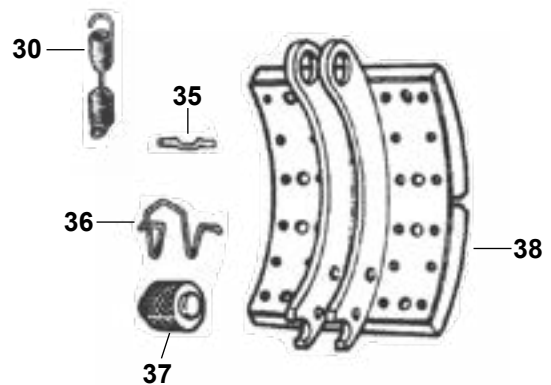



# FREIGHTER A19H & F22H / DANA SPICER STANDARD FORGE LATE AXLE

12-1/4" x 7 1/2 BRAKE (FABRICATED SHOE)

ITEM NUMBER	PART NUMBER	DESCRIPTION
1	E-975	HUB CAP - GREASE
2	E-03009	HUB CAP GASKET - MULTI DRILLED 3, 5, 6 HOLE
3	E-572	OUTER AXLE SPINDLE NUT
4	E-2237	LOCK TAB WASHER
5	E-573	LOCK WASHER
6	E-540	INNER AXLE SPINDLE NUT
7	MERSET413	OUTER BEARING SET (HM212011/49) (SEE NOTE 1)
8	MERSET405	INNER BEARING SET (663/653) (SEE NOTE 2)
8	MERSET414	INNER BEARING SET (HM218210/48) (SEE NOTE 3)
9	MER0113	HUB SEAL - A19H AXLE
9	MER0143	HUB SEAL - F22H, DANA, S/FORGE AXLE
10	E-2392	CIRCLIP
11	E-2391	WASHER
12	E-2389	ANCHOR PIN BUSH
13	E-2390	ANCHOR PIN
14	E-656	D' WASHER
15	E-1416	SEAL
16	E-759	OUTER CAM BUSH - NYLON
16A	E-807	OUTER CAM BUSH - BRONZE
17	E-2409	CAMSHAFT SPACER WASHER
18	1229Z1118	CIRCLIP
19	E-2102	INNER CAM BUSH
20	E-2365	RETAINER PLATE
21	E-2091	SLACK ADJUSTER - 1 HOLE CURVED, 10 SPLINE
21A	E-612S-BK	SLACK ADJUSTER - 3 HOLE, 10 SPLINE
22	E-580	CAMSHAFT SPACER WASHER
23	E-1411	S' CAM LH - CONTACT CUSTOMER SERVICE FOR ALTERNATES
23	E-1410	S' CAM RH - CONTACT CUSTOMER SERVICE FOR ALTERNATES
24	E-4737A	CAM ENCLOSURE
25	E-4739	PLATE
26	E-7775	WHEEL NUT
27	E-5571A	WHEEL CLAMP (FOR 5/6 SPOKE HUBS ONLY)
28	R004956A	STUD
29	03-122963-002	BRAKE DRUM - 8-1/2" SPIGOT / 10" PCD

More Parts Next Page 



# FREIGHTER A19H & F22H / DANA SPICER STANDARD FORGE LATE AXLE

12-1/4" x 7 1/2 BRAKE (FABRICATED SHOE)

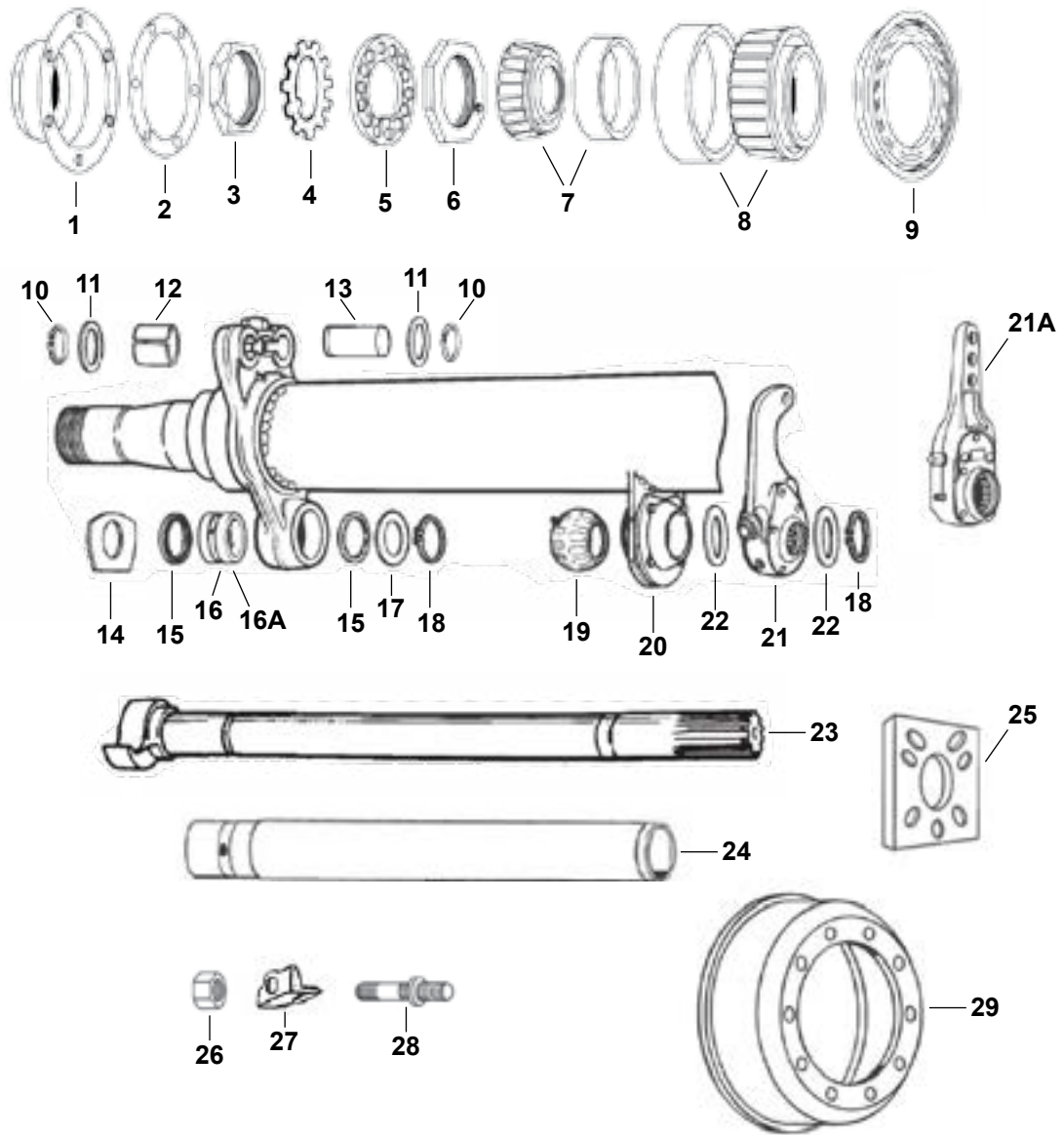

## EARLY BRAKE SHOE

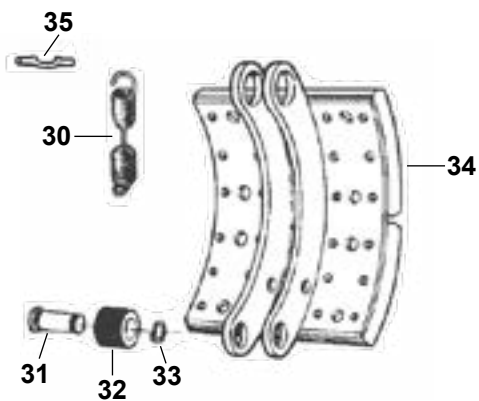

## LATE BRAKE SHOE

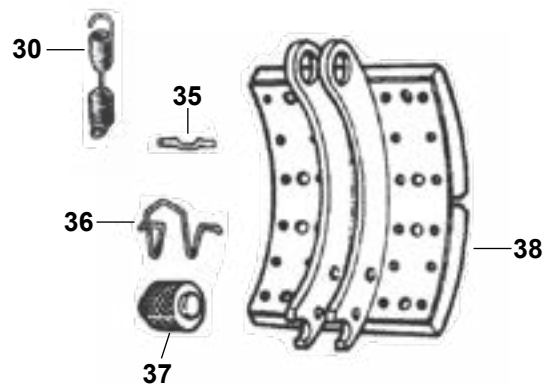

# FREIGHTER A19H & F22H / DANA SPICER STANDARD FORGE LATE AXLE

12-1/4" x 7 1/2 BRAKE (FABRICATED SHOE)

ITEM NUMBER	PART NUMBER	DESCRIPTION
30	2258V256	RETURN SPRING
31	E-2396	ROLLER PIN
32	E-2395	ROLLER
33	E-527	CIRCLIP
34	-	LINED BRAKE SHOE (NOT SOLD SEPARATELY - PART OF KIT KMG14591S)
35	E-747	SPRING RETAINER
36	E-539	ROLLER RETAINER
37	2297T7222	ROLLER - SMOOTH
37	E-2177	ROLLER - KNURLED
37	E-2215	ROLLER - KNURLED 1/8" OVERSIZE
37	E-781	ROLLER - SMOOTH 1/8" OVERSIZE
37	E-586	ROLLER - SMOOTH 1/4" OVERSIZE
38	SMA2124692FC2	LINED BRAKE SHOE (NOT SOLD SEPARATELY - PART OF KIT KSMA2124692FC2)
38	SMG2A4692	LINED BRAKE SHOE (NOT SOLD SEPARATELY - PART OF KIT EKSMG2A4692)

KIT	E-2402HD	HEAVY DUTY BRAKE KIT, EARLY TYPE BRAKE SHOE - SERVICES 1 WHEEL
KIT	E-3373HD	HEAVY DUTY BRAKE KIT, LATE TYPE BRAKE SHOE - SERVICES 1 WHEEL
KIT	E-2287	CAMSHAFT BUSH KIT. CAMSHAFT BUSH KIT SERVICES 1 AXLE.
KIT	E-2402HD	HEAVY DUTY BRAKE KIT, EARLY TYPE BRAKE SHOE. BRAKE HARDWARE KITS SERVICE 1 WHEEL.
KIT	E-3373HD	HEAVY DUTY BRAKE KIT, LATE TYPE BRAKE SHOE. BRAKE HARDWARE KITS SERVICE 1 WHEEL.
KIT	E-2287	CAMSHAFT BUSH KIT. CAMSHAFT BUSH KIT SERVICES 1 AXLE.
KIT	KMG14591S	4591 MAJOR BRAKE SHOE KIT - CONSISTS OF 2 LINED SHOES & HARDWARE KIT - SERVICES 1 WHEEL.
KIT	KSMA2124692**	4692 MAJOR BRAKE SHOE KIT - CONSISTS OF 2 LINED SHOES & HARDWARE KIT - SERVICES 1 WHEEL.
KIT	EKSMG2A4692*	4692 MAJOR BRAKE SHOE KIT - CONSISTS OF 2 LINED SHOES & HARDWARE KIT - SERVICES 1 WHEEL.
KIT	KSMA2124692FC2**	4692 MAJOR BRAKE SHOE KIT - CONSISTS OF 2 LINED SHOES & HARDWARE KIT - SERVICES 1 WHEEL.

\* Please contact Customer Service for details on other grades of friction material available.

\*\* Restricted sale.

Note 1: For Freighter A19H, F22H, Dana Spicer, Standard Forge

Note 2: For Freighter A19H, F22H

Note 3: For Freighter F22H, Dana Spicer, Standard Forge



# EATON JE 501

16 1/2" x 7" BRAKES

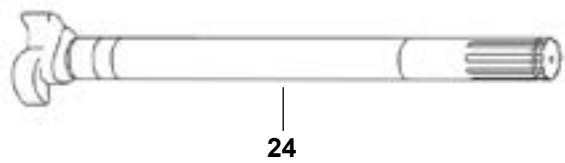
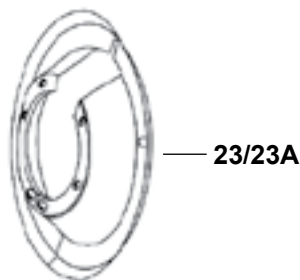
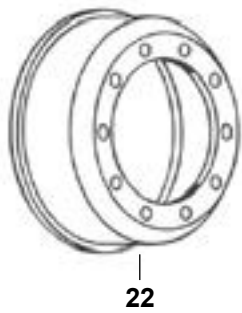
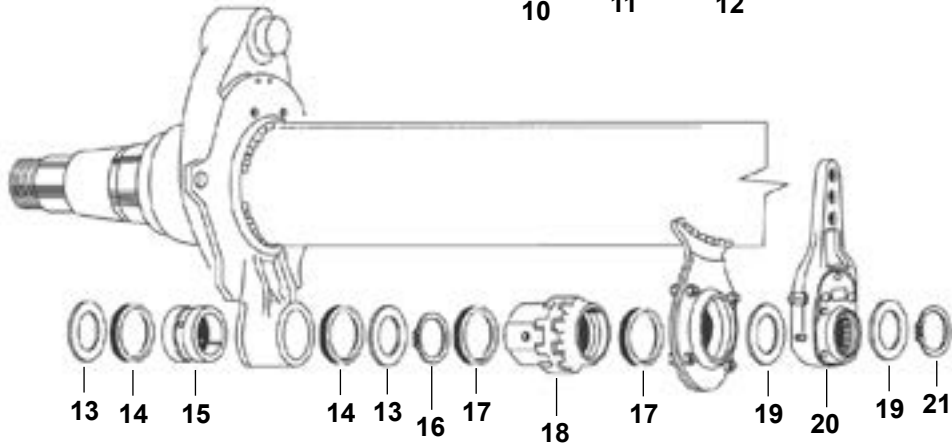
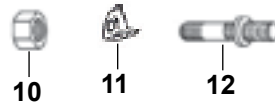
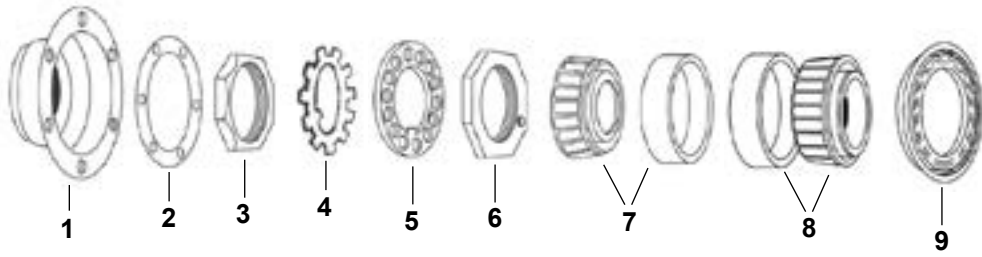

## "Q" TYPE BRAKE

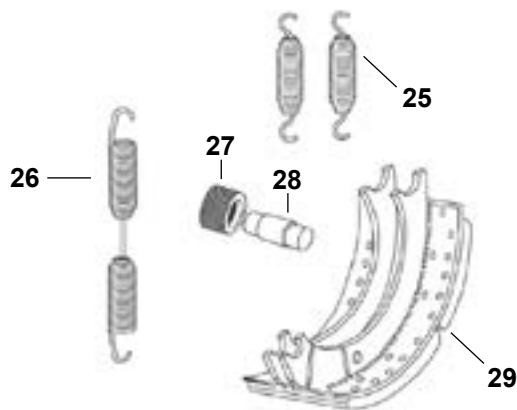

# EATON JE 501

16 1/2" x 7" BRAKES

ITEM NUMBER	PART NUMBER	DESCRIPTION
1	E-975	HUB CAP - GREASE
2	E-03009	HUB CAP GASKET - MULTI DRILLED 3, 5, 6 HOLE
3	E-572	OUTER AXLE SPINDLE NUT
4	E-2237	LOCK TAB WASHER
5	E-573	LOCK WASHER
6	E-540	INNER AXLE SPINDLE NUT
7	MERSET413	OUTER BEARING SET (HM212049 / HM212011)
8	MERSET414	INNER BEARING SET (HM218248 / HM218210)
9	MER0143	HUB SEAL
10	E-7775	WHEEL NUT
11	E-5571A	WHEEL CLAMP (FOR 5/6 SPOKE HUBS ONLY)
12	R004956A	WHEEL STUD
13	E-1565	WASHER - 2'3/8" OD X 1-5/8" X 1/16"
14	E-2405	CAMSHAFT SEAL
15	E-2690A	BUSH
16	E-1569	CAMSHAFT LOCK RING
17	E-1416A	CAMSHAFT SEAL INNER
18	E-2695	BUSH
19	E-580	WASHER - 2-1/4" OD X 1-1/2" ID X 1/16"
20	E-612S-BK	SLACK ADJUSTER - 3 HOLE X 10 SPLINE
21	1229Z1118	CIRCLIP
22	03-122222-002	BRAKE DRUM 11" PCD 9.44" SPIGOT 5 & 6 BOLT HOLES
23	E-886	BACKING PLATE (STEEL)
23A	E-3775	BACKING PLATE (PLASTIC)
24	E-2693	S' CAM LH
24	E-2694	S' CAM RH
25	E-1418	SPRING - 2 PER WHEEL
26	E-2785	SPRING - 1 PER WHEEL
27	E-595	ROLLER, SMOOTH
27	E-2217A	ROLLER, KNURLED

More Parts Next Page 



# EATON JE 501

16 1/2" x 7" BRAKES

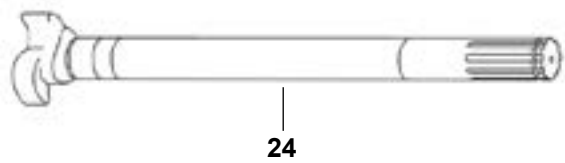
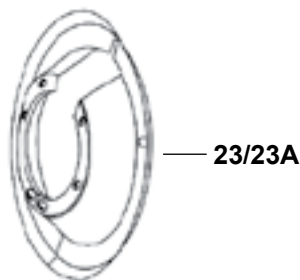
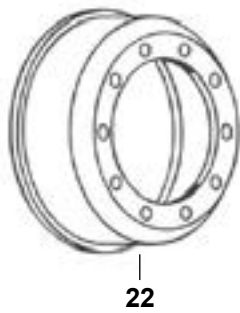
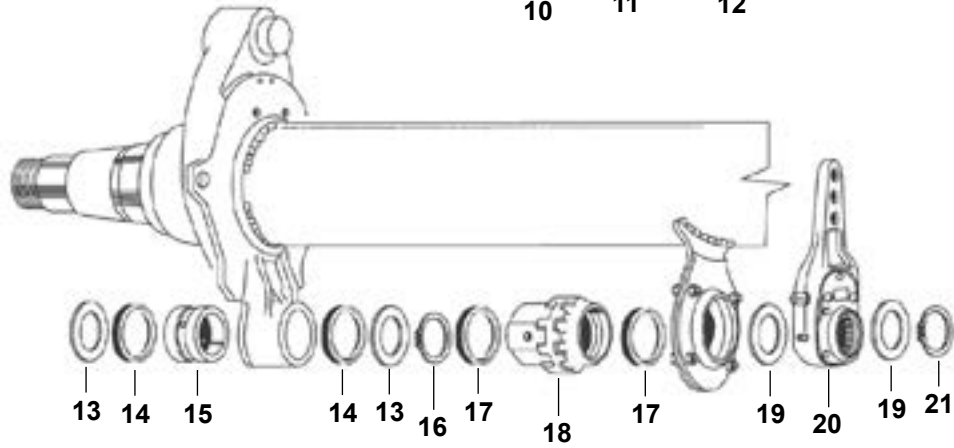
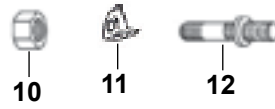
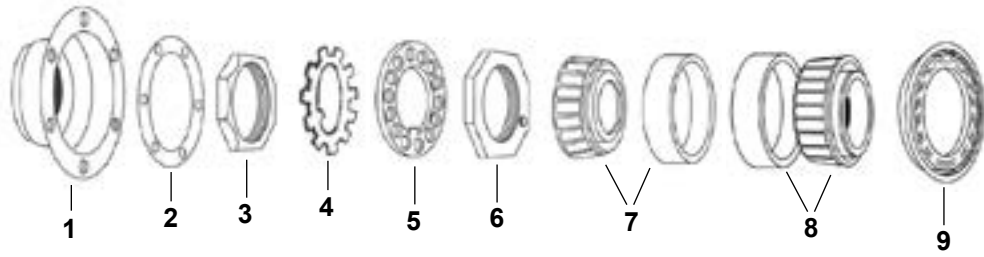

## "Q" TYPE BRAKE

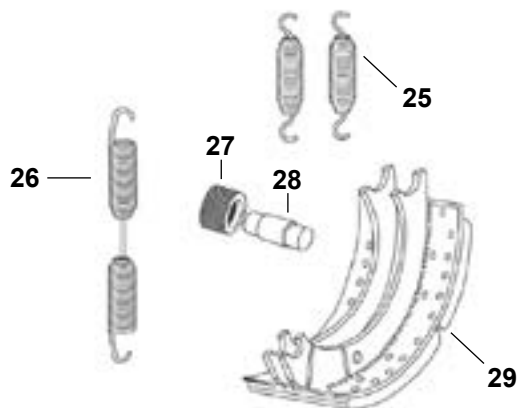

# EATON JE 501

16 1/2" x 7" BRAKES

ITEM NUMBER	PART NUMBER	DESCRIPTION
28	E-596A	ROLLER SHAFT
29	E-2819	BRAKE SHOE - UNLINED
29	-	LINED BRAKE SHOE (NOT SOLD SEPARATELY - PART OF KITS KSMA2124311E & EKSMG2A4311E)

KIT	E-2696A	CAMSHAFT BUSH KIT INCLUDES ITEMS 13, 14, 15, 16, 18, 19 & 21. CAMSHAFT REPAIR KIT SERVICES 1 AXLE
KIT	E-1887AHD	HARDWARE KIT FOR MINOR REPAIR. SERVICES 1 WHEEL
KIT	KSMA2124311E**	4311J - MAJOR BRAKE SHOE KIT - CONSISTS OF 2 LINED SHOES & HARDWARE KIT - SERVICES 1 WHEEL.
KIT	EKSMG2A4311E*	4311J - MAJOR BRAKE SHOE KIT - CONSISTS OF 2 LINED SHOES & HARDWARE KIT - SERVICES 1 WHEEL.

\* Please contact Customer Service for details on other grades of friction material available.

\*\* Restricted sale.



# EATON E34

15" AXLE - 12-1/4" x 7-1/2" BRAKES

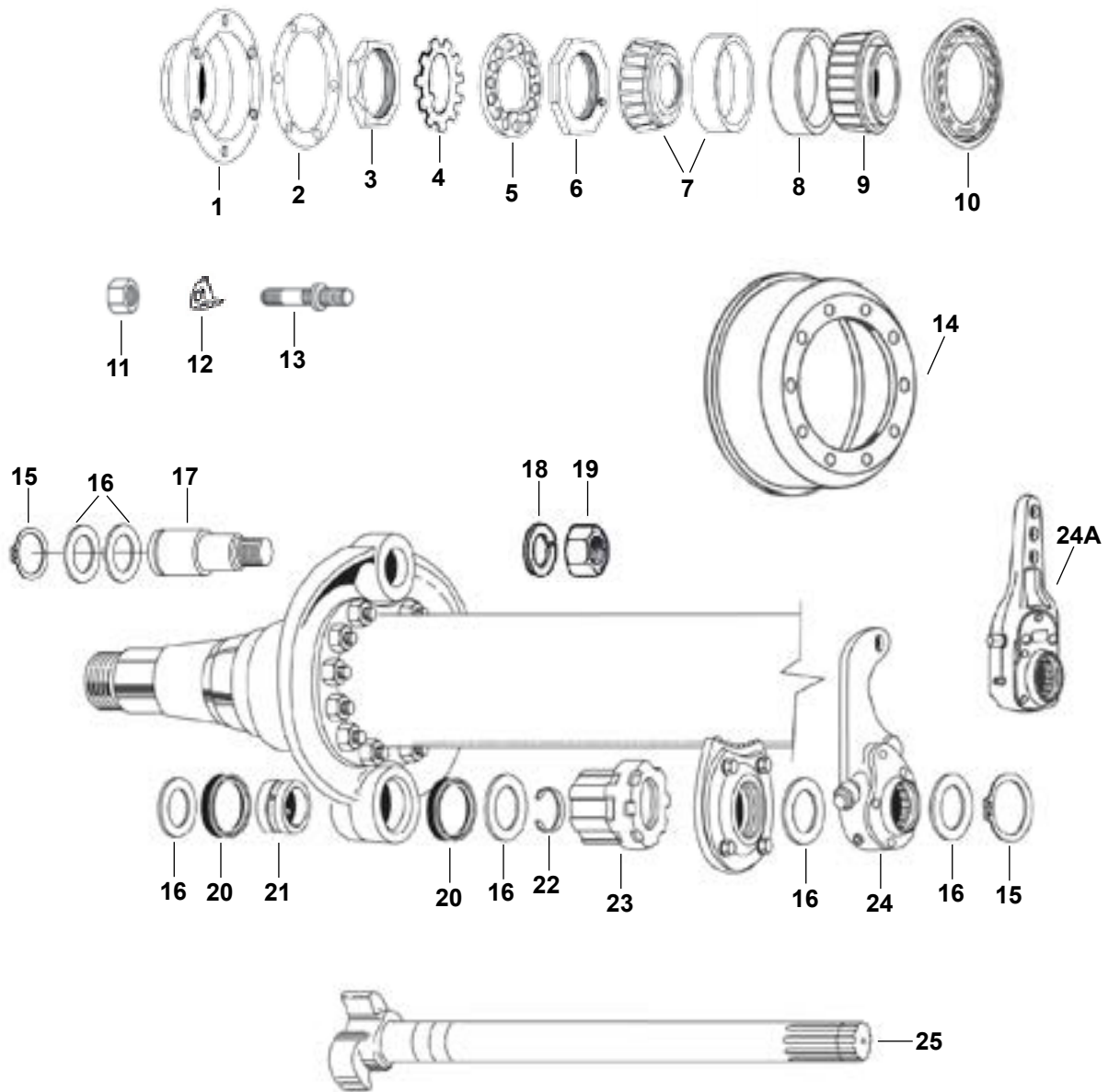

## "Q" TYPE BRAKE

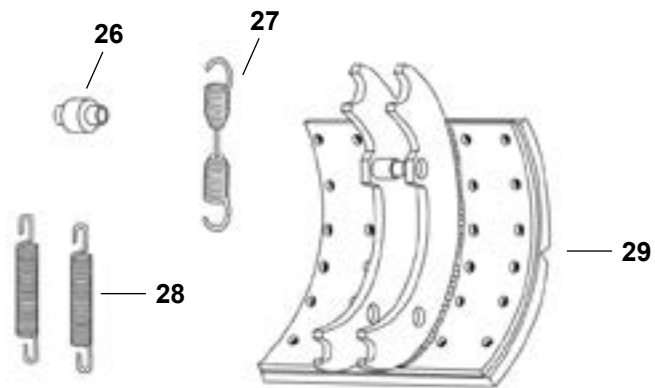



# EATON E34

## 15" AXLE - 12-1/4" x 7-1/2" BRAKES

ITEM NUMBER	PART NUMBER	DESCRIPTION
1	E-975	HUB CAP - GREASE
2	E-03009	HUB CAP GASKET - MULTI DRILLED
3	E-572	OUTER AXLE SPINDLE NUT
4	E-2237	LOCK TAB WASHER
5	E-573	LOCK WASHER
6	E-540	INNER AXLE SPINDLE NUT
7	MERSET413	OUTER BEARING SET (HM212049 / HM212011)
8	653	INNER BEARING CUP
9	665A	INNER BEARING CONE
10	TBA	HUB SEAL
11	E-7775	WHEEL NUT
12	E-5571A	WHEEL CLAMP (FOR 5/6 SPOKE HUBS ONLY)
13	R004956A	STUD
14	03-122963-002	BRAKE DRUM - 8-1/2" SPIGOT / 10" PCD
14	03-122971-002	BRAKE DRUM - 7-1/4" SPIGOT / 8-1/4" PCD
15	1229Z1118	CIRCLIP
16	E-580	WASHER
17	-	ANCHOR PIN (PART OF KIT E-2126)
18	-	LOCK WASHER (PART OF KIT E-2126)
19	-	NUT (PART OF KIT E-2126)
20	E-1416A	SEAL
21	1225L1208	BUSH
22	E-1569	CAMSHAFT LOCK RING
23	E-1385	BUSH
24	E-2091	SLACK ADJUSTER - 1 HOLE. CURVED, 10 SPLINE
24A	E-612S-BK	SLACK ADJUSTER - 3 HOLE. STRAIGHT, 10 SPLINE
25	E-1394	S' CAM LH
25	E-1393	S' CAM RH
26	E-2208	ROLLER
26A	E-1406	ROLLER 1/4" OVERSIZE
27	R567004	SPRING - 1 PER WHEEL
28	E-1400	SPRING - 2 PER WHEEL
29	E-1398	BRAKE SHOE - UNLINED
KIT	E-2126	HARDWARE KIT (INCLUDES ITEMS 15, 16, 17, 18, 19, 26A, 27 & 28)



# EATON 541 SERIES BRAKES

16-1/2" DIAMETER BRAKES

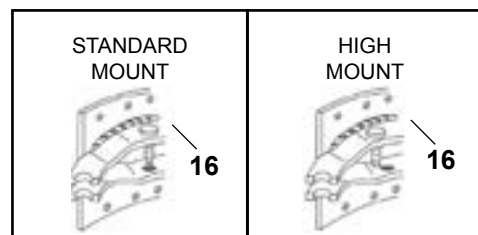
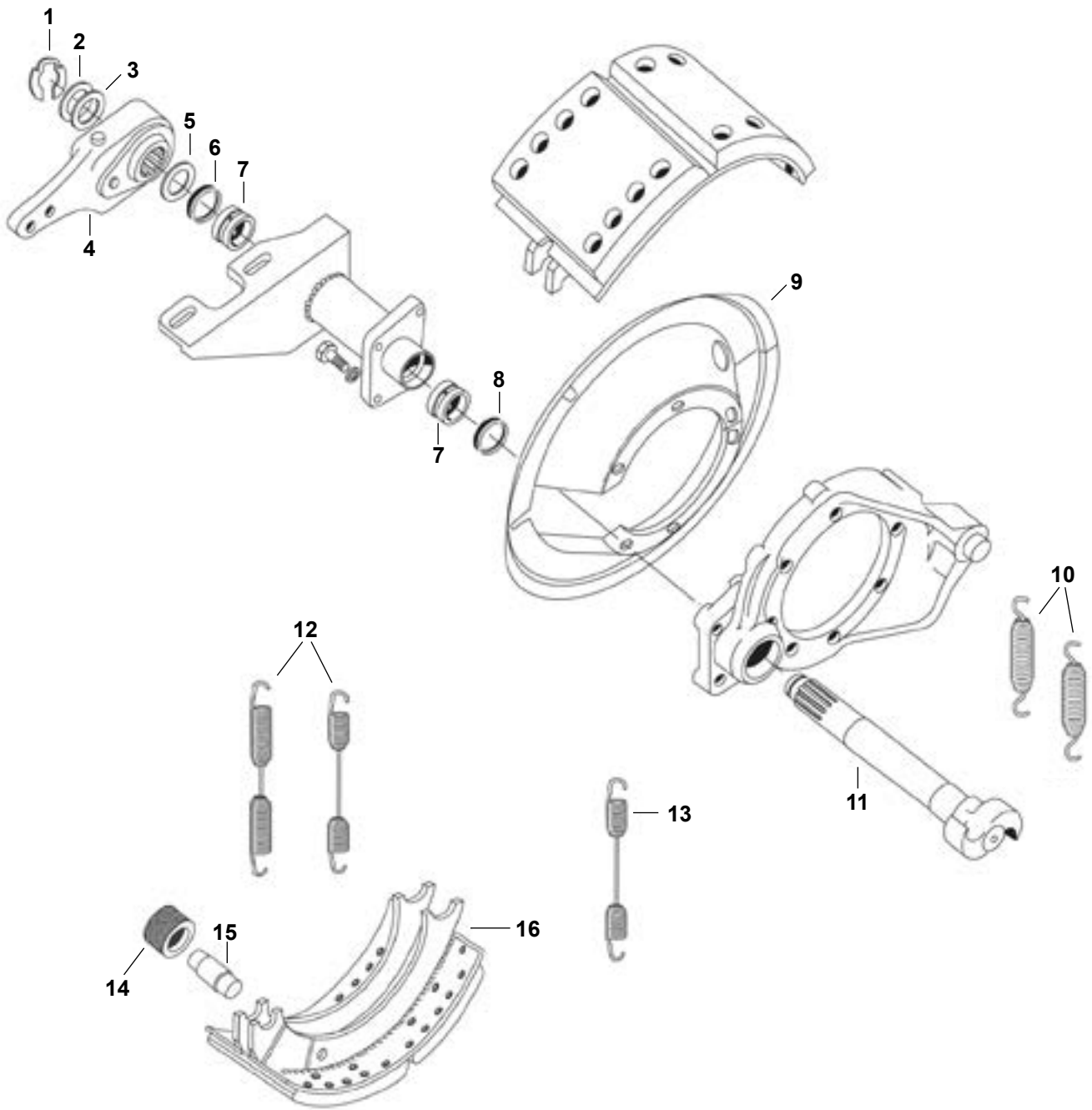

# EATON 541 SERIES BRAKES

## 16-1/2" DIAMETER BRAKES

PART NUMBER	PART NUMBER	DESCRIPTION
1	E-3234	SNAP RING
2	E-1781	WASHER OD 2" X ID 1.14" X TH 0.03"
3	R627005	WASHER OD 2" X ID 1.14" X TH 0.06"
4	E-940SBK	SLACK ADJUSTER
5	E-580	WASHER OD 2.25" X ID 1.53" X TH 0.06"
6	E-1416	SEAL
7	1225L1208	BUSH
8	E-1416A	SEAL
9	E-2807	DUST SHIELD
10	E-1418	RETAINING SPRING
11	E-2800	S' CAM L/H 8 9/16" - CONVENTIONAL BRAKE
11	E-2799	S' CAM R/H 8 9/16" - CONVENTIONAL BRAKE
11	E-1776	S' CAM L/H 11 5/8" - CONVENTIONAL BRAKE
11	E-1775	S' CAM R/H 11 5/8" - CONVENTIONAL BRAKE
12	E-1428A	RETURN SPRING
13	E-2785	RETURN SPRING (OPTIONAL)
13	E-2475	RETURN SPRING HIGH MOUNT SHOES
14	E-595	ROLLER - SMOOTH
14	E-2217A	ROLLER - KNURLED
15	E-596A	ROLLER SHAFT
16	-	LINED BRAKE SHOE (NOT SOLD SEPARATELY - PART OF KIT KSMA2124311E)
16	-	LINED BRAKE SHOE (NOT SOLD SEPARATELY - PART OF KIT EKSMG2A4311E)
16	E-1777	UNLINED BRAKE SHOE - 6" 4317G
16	E-2474	UNLINED BRAKE SHOE - 5" 4223A

KIT	E-1887AHD	BRAKE HARDWARE KITS SERVICE 1 WHEEL
KIT	KSMA2124311E**	4311 MAJOR BRAKE SHOE KIT - CONSISTS OF 2 LINED SHOES & HARDWARE KIT - SERVICES 1 WHEEL.
KIT	EKSMG2A4311E*	4311 MAJOR BRAKE SHOE KIT - CONSISTS OF 2 LINED SHOES & HARDWARE KIT - SERVICES 1 WHEEL.

\* Please contact Customer Service for details on other grades of friction material available.

\*\* Restricted sale.



**EATON "ES"**  
EXTENDED SERVICE BRAKES  
16-1/2" DIAMETER

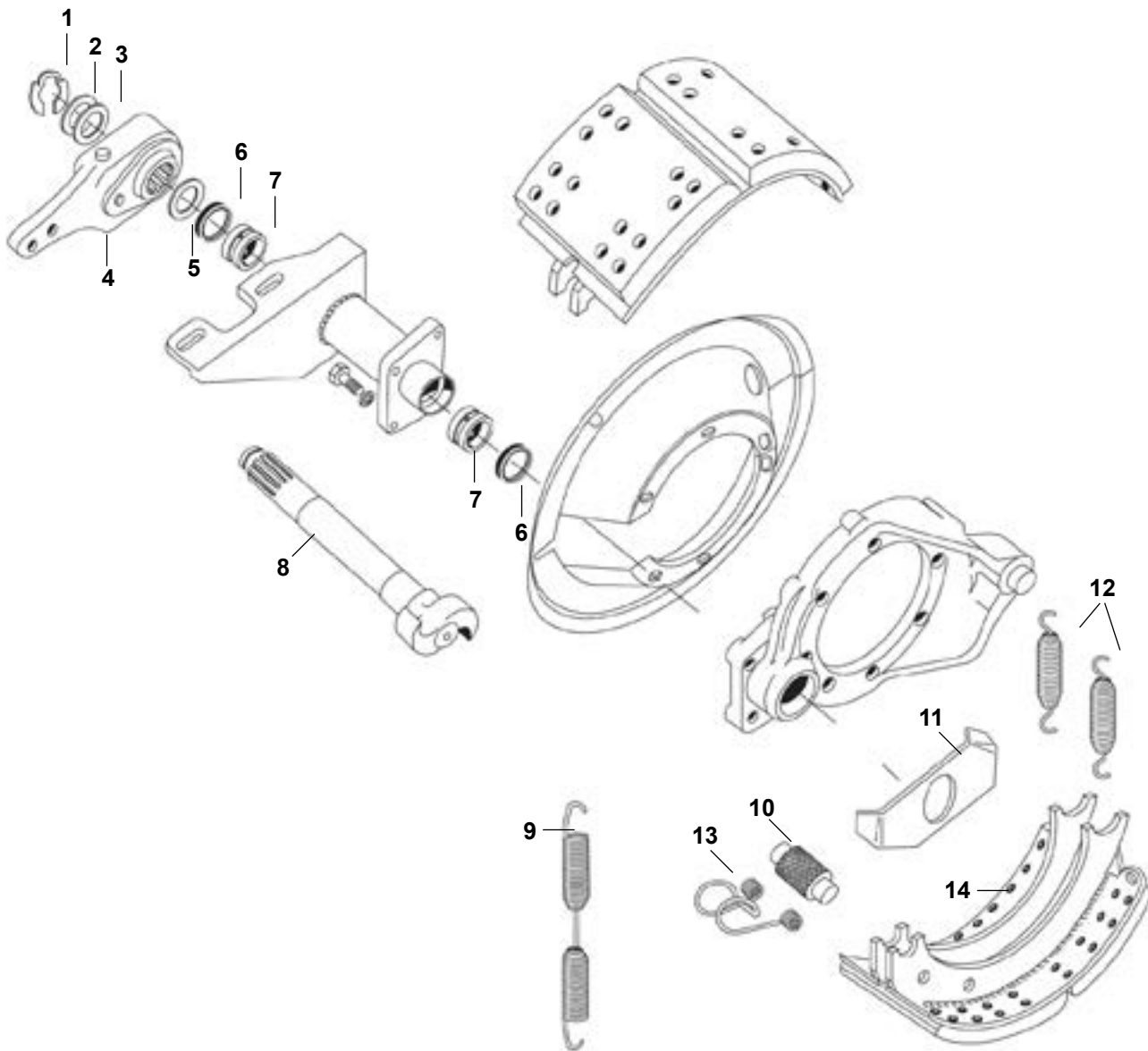

# EATON "ES"

## EXTENDED SERVICE BRAKES

### 16-1/2" DIAMETER

ITEM NUMBER	PART NUMBER	DESCRIPTION
1	E-3234	SNAP RING
2	E-1781	WASHER OD 2" X ID 1.14" X TH 0.03"
3	R627005	WASHER OD 2" X ID 1.14" X TH 0.06"
4	E-940SBK	SLACK ADJUSTER
5	E-580	WASHER OD 2.25" X ID 1.53" X TH 0.06"
6	E-1416A	SEAL
7	1225L1208	BUSH
8	E-9771	1/2" X 1/2: 10 SPLINE CAMSHAFT LH
9	E-10197	RETURN SPRING
10	E-5477	BRAKE ROLLER
11	E-5482	CAM HEAD WASHER
12	E-1418	RETAINING SPRING
13	E-539	CAM ROLLER RETAINER
14	-	LINED BRAKE SHOE 7" 4709 - NOT SOLD SEPARATELY - PART OF KIT KSMA2124709E1
14	-	LINED BRAKE SHOE 7" 4709 - NOT SOLD SEPARATELY - PART OF KIT EKSMG2A4709E1

KIT	E-4709ES-N	BRAKE HARDWARE KIT - STANDARD MOUNT
KIT	KSMA2124709E1**	4709 - MAJOR BRAKE SHOE KIT - CONSISTS OF 2 LINED SHOES & HARDWARE KIT - SERVICES 1 WHEEL.
KIT	EKSMG2A4709E1*	4709 - MAJOR BRAKE SHOE KIT - CONSISTS OF 2 LINED SHOES & HARDWARE KIT - SERVICES 1 WHEEL.

\* Please contact Customer Service for details on other grades of friction material available.

\*\* Restricted sale.



# EATON "ESII"

EXTENDED SERVICE BRAKES  
16-1/2" DIAMETER BRAKES

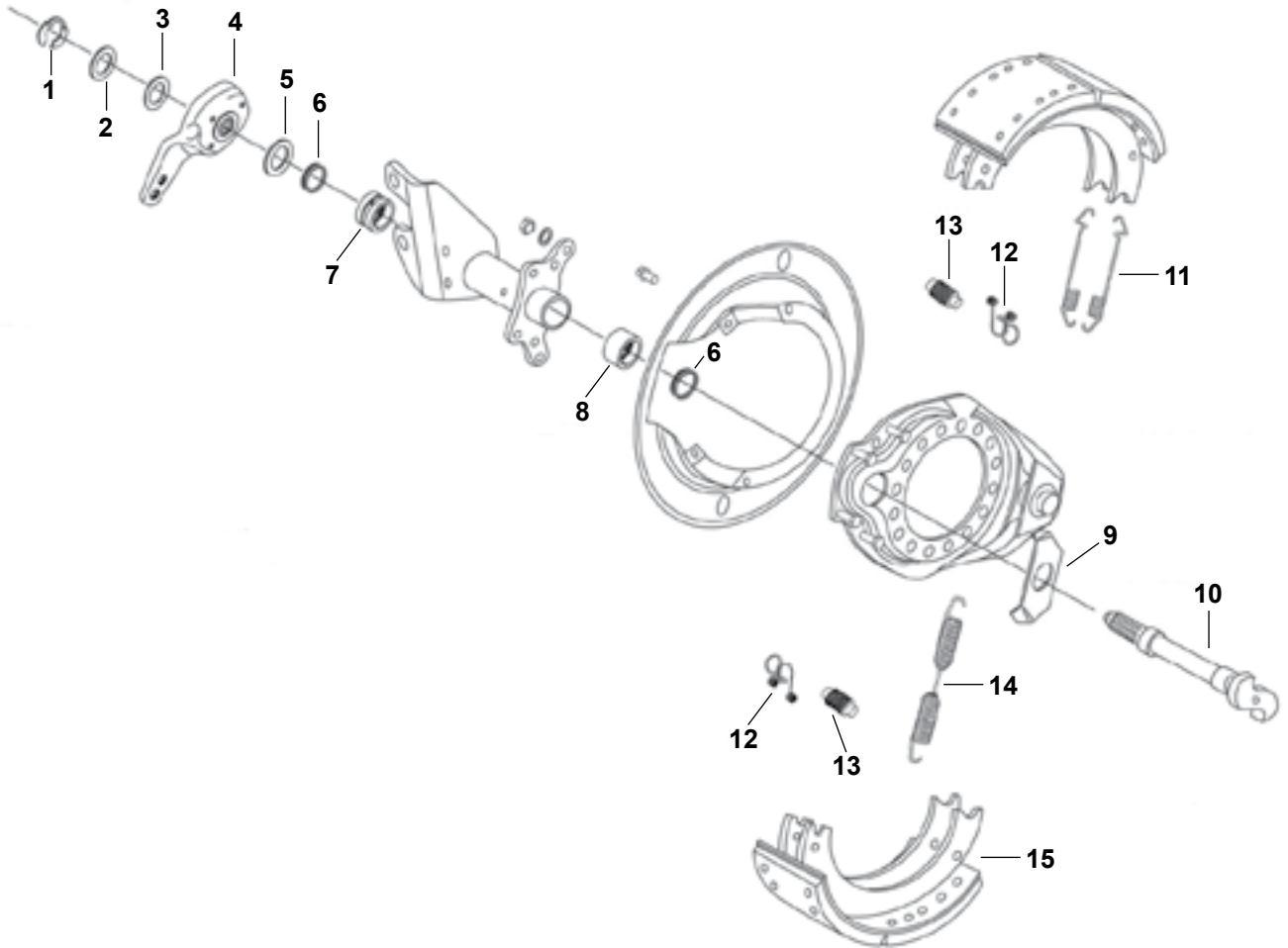

# EATON "ESII"

## EXTENDED SERVICE BRAKES 16-1/2" DIAMETER BRAKES

ITEM NUMBER	PART NUMBER	DESCRIPTION
1	E-3234	SNAP RING
2	E-1781	WASHER OD 2" X ID 1.14" X TH 0.03"
3	R627005	WASHER OD 2" X ID 1.14" X TH 0.06"
4	E-940SBK	SLACK ADJUSTER
5	E-580	WASHER OD 2.25" X ID 1.53" X TH 0.06"
6	E-1416	SEAL
7	1225L1208	BUSH
8	E-667	BUSH (BRONZE)
9	E-5482	CAM HEAD WASHER
10	E-9771	1/2" X 1/2: 10 SPLINE CAMSHAFT LH
10	E-9772	1/2" X 1/2: 10 SPLINE CAMSHAFT RH
11	E-10198	RETAINING SPRING
12	E-5478	CAM ROLLER RETAININER
13	E-5477	BRAKE ROLLER
14	E-10197	RETURN SPRING
15	-	LINED BRAKE SHOE (NOT SOLD SEPARATELY - PART OF KIT KSMA2124709E2)
15	-	LINED BRAKE SHOE (NOT SOLD SEPARATELY - PART OF KIT EKSMG2A4709E2)
15	E-10270	UNLINED BRAKE SHOE 5" (4719)
15	E-10271	UNLINED BRAKE SHOE 6" (4725)

KIT	E-10244	BRAKE HARDWARE KIT. SERVICES 1 WHEEL
KIT	KSMA2124709E2**	4709 - MAJOR BRAKE SHOE KIT - CONSISTS OF 2 LINED SHOES & HARDWARE KIT - SERVICES 1 WHEEL.
KIT	EKSMG2A4709E2*	4709 - MAJOR BRAKE SHOE KIT - CONSISTS OF 2 LINED SHOES & HARDWARE KIT - SERVICES 1 WHEEL.
KIT	E-10897	CAM SHAFT REPAIR KIT

\* Please contact Customer Service for details on other grades of friction material available.

\*\* Restricted sale.



# FREIGHTER MKV

16-1/2" X 7" BRAKES

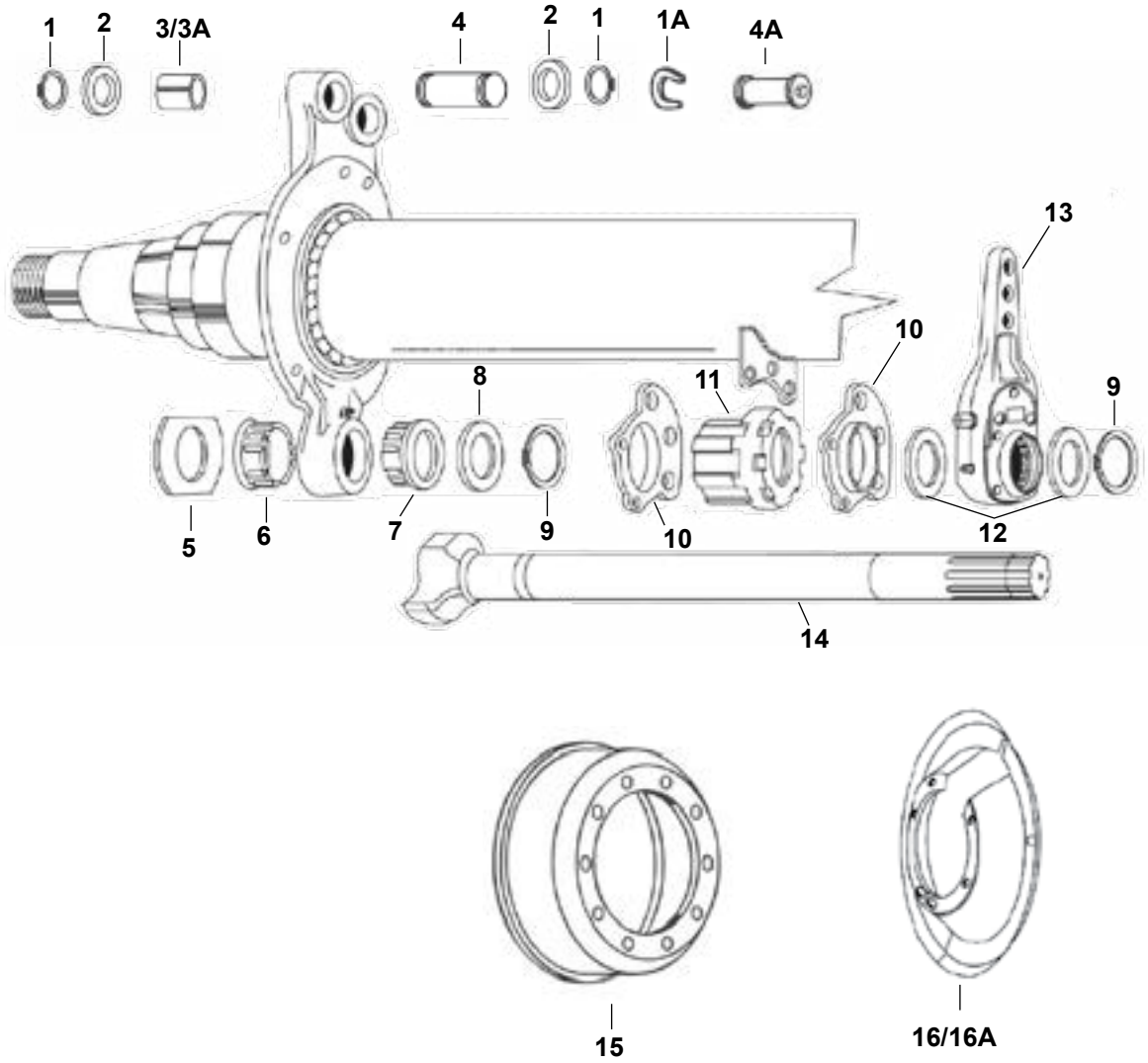

## H/D RETAINER OPTION

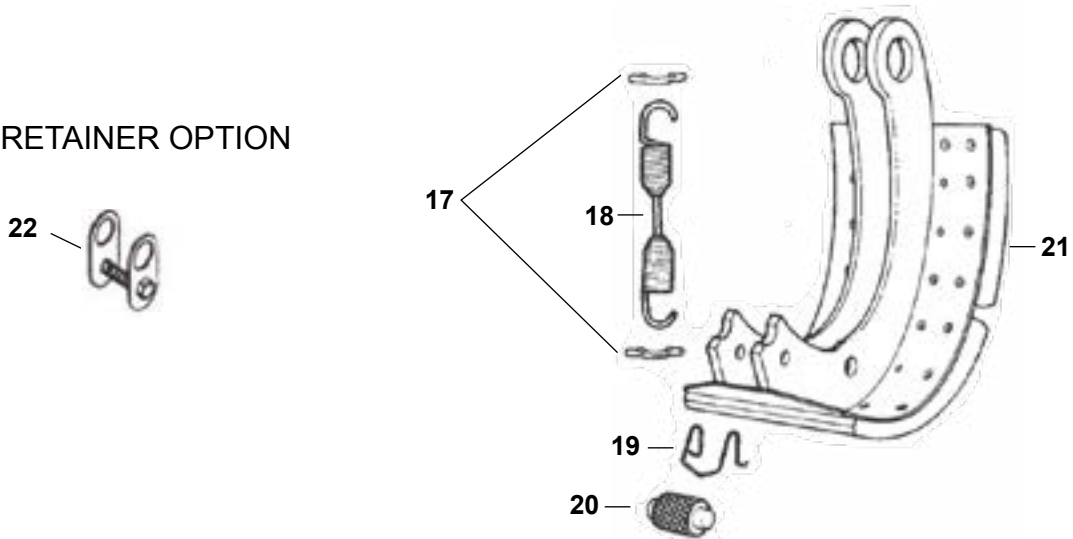



# FREIGHTER MKV

16-1/2" X 7" BRAKES

ITEM NUMBER	PART NUMBER	DESCRIPTION
1	1229X1116	CIRCLIP
1A	E-1106	OPTIONAL 'C' TYPE CIRCLIP
2	E-1113	WASHER
3	E-1893	ANCHOR PIN BUSH - STAINLESS STEEL
3A	1225B496	ANCHOR PIN BUSH - BRONZE LINED
4	1259M1131	ANCHOR PIN - STANDARD (CIRCLIP TYPE)
4A	-	ANCHOR PIN - BOLT ON TYPE LONG (NOT SOLD SEPARATELY - PART OF KIT E-8465AU)
5	E-656	D' WASHER
6	E-943	BUSH (WHITE)
7	E-943	BUSH (YELLOW)
8	E-580	WASHER - 2.25" OD X 1.53" ID X0.06"
9	1229Z1118	CIRCLIP
10	E-603	RETAINER PLATE
11	E-535	BUSH
12	1229Q771	WASHER CAMSHAFT SPACER
13	E-612SBK	SLACK ADJUSTER - 1-1/2" X 10 SPLINE
14	E-1425A	CAMSHAFT - LH
14	E-1424A	CAMSHAFT - RH
15	TBA	BRAKE DRUM, 10 HOLE
16	E-886	BACKING PLATE (STEEL)
16A	E-3775	BACKING PLATE (PLASTIC)
17	E-747	RETAINING PIN
18	E-1880B	RETURN SPRING
19	E-539	ROLLER RETAINER
20	2297T7222	ROLLER - SMOOTH
20	E-2177	ROLLER - KNURLED
20	E-2215	ROLLER - KNURLED 1/8" OVERSIZE
20	E-781	ROLLER - SMOOTH 1/8" OVERSIZE
20	E-586	ROLLER - SMOOTH 1/4" OVERSIZE
21	E-2241	BRAKE SHOE - UNLINED (LINING REF. 4515E)
21	-	LINED BRAKE SHOE (NOT SOLD SEPARATELY - PART OF KIT EKSMG2A4515PHD)
22	-	BOLT-ON ROLLER RETAINER KIT (NOT SOLD SEPARATELY - PART OF KIT E-8465AU)

More Parts Next Page 



# FREIGHTER MKV

16-1/2" X 7" BRAKES

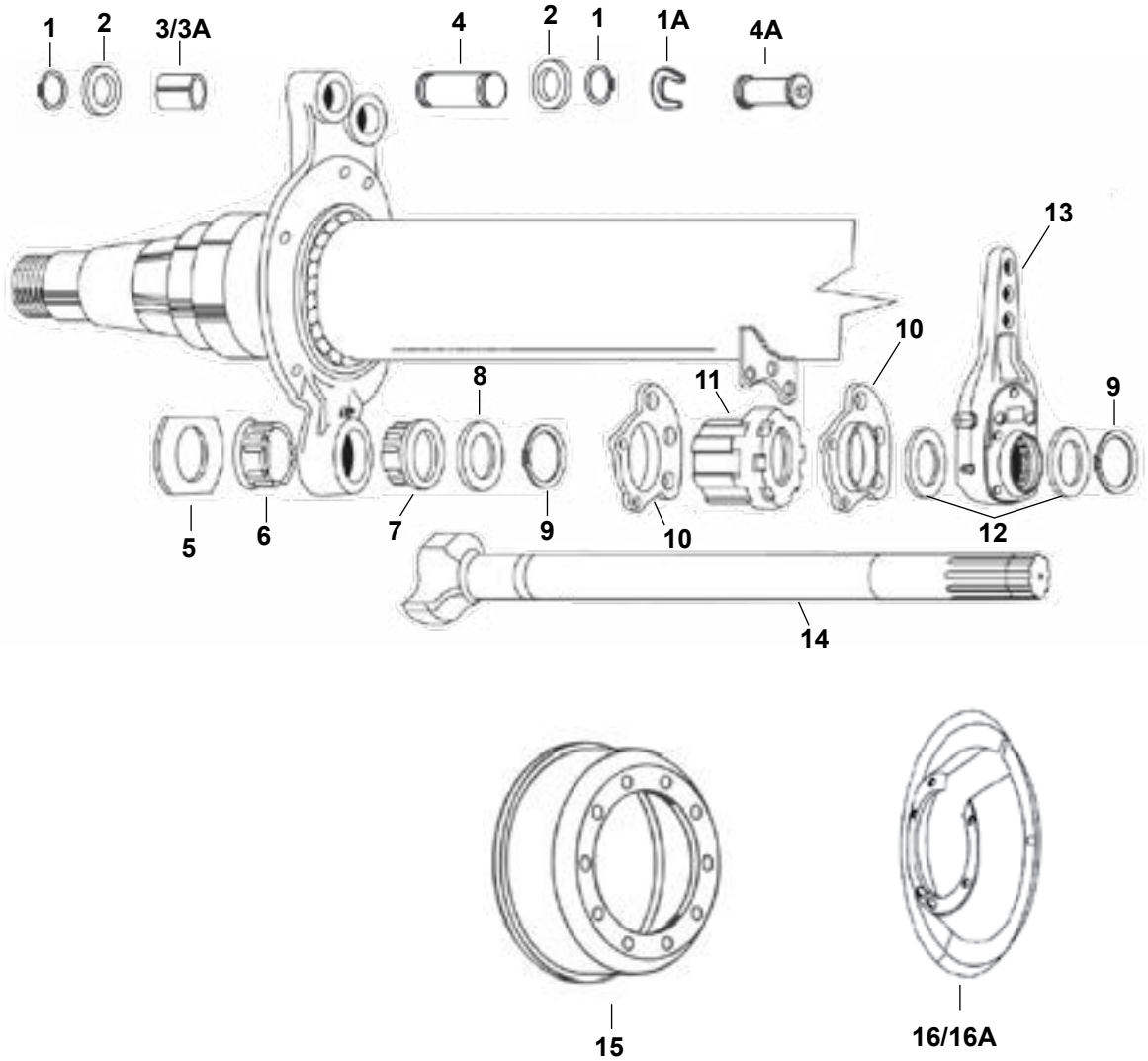

H/D RETAINER OPTION

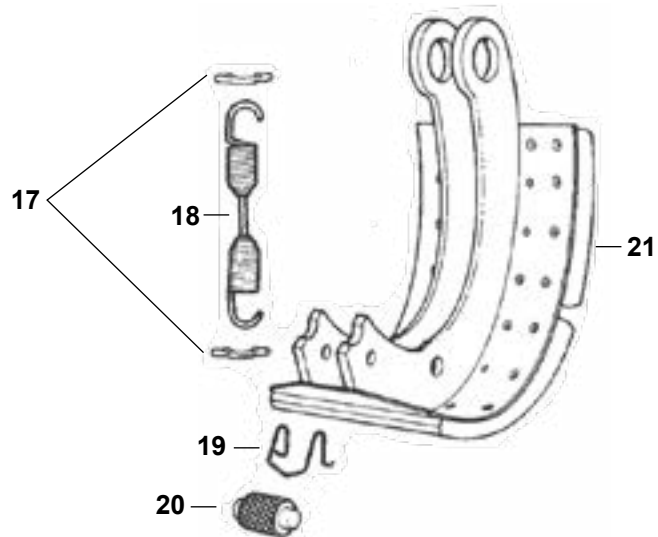
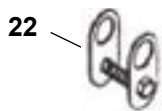

# FREIGHTER MKV

16-1/2" X 7" BRAKES

ITEM NUMBER	PART NUMBER	DESCRIPTION
KIT	E-1357A	CAMSHAFT BUSH KIT. CAMSHAFT REPAIR KIT SERVICES 1 AXLE.
KIT	EKSMG2A4515PHD*	4515P - MAJOR BRAKE SHOE KIT - CONSISTS OF 2 LINED SHOES & HARDWARE KIT - SERVICES 1 WHEEL.
KIT	EKSMG2A4515PSS*	4515P - SHOE WITH WELDED WASHERS AND SMOOTH ROLLERS - MAJOR BRAKE SHOE KIT - CONSISTS OF 2 LINED SHOES & HARDWARE KIT - SERVICES 1 WHEEL.
KIT	EKSMG2A4515PSSK*	4515P - SHOE WITH WELDED WASHERS AND KNURLED ROLLERS - MAJOR BRAKE SHOE KIT - CONSISTS OF 2 LINED SHOES & HARDWARE KIT - SERVICES 1 WHEEL.
KIT	PKSMA2124515P**	4515-P MAJOR BRAKE SHOE KIT - CONSISTS OF 2 LINED SHOES & HARDWARE KIT - SERVICES 1 WHEEL.
KIT	PKSMA2124515PSS**	4515-P (WITH WELDED WASHER) MAJOR BRAKE SHOE KIT - CONSISTS OF 2 LINED SHOES & HARDWARE KIT - SERVICES 1 WHEEL.



### Found an error?

If you detect any errors in this catalogue, please let us know. We want to ensure the information we publish is as accurate as possible. We appreciate your help in making this happen.

Please forward your enquiries to:  
**Email:** [meritoraftermarketau@meritor.com](mailto:meritoraftermarketau@meritor.com)  
**Phone:** (03) 8353 6050

\* Please contact Customer Service for details on other grades of friction material available.

\*\* Restricted sale.



# FREIGHTER - INGERSOLL (IMT)

A22H / F22H AXLE  
16-1/2" X 7" BRAKES

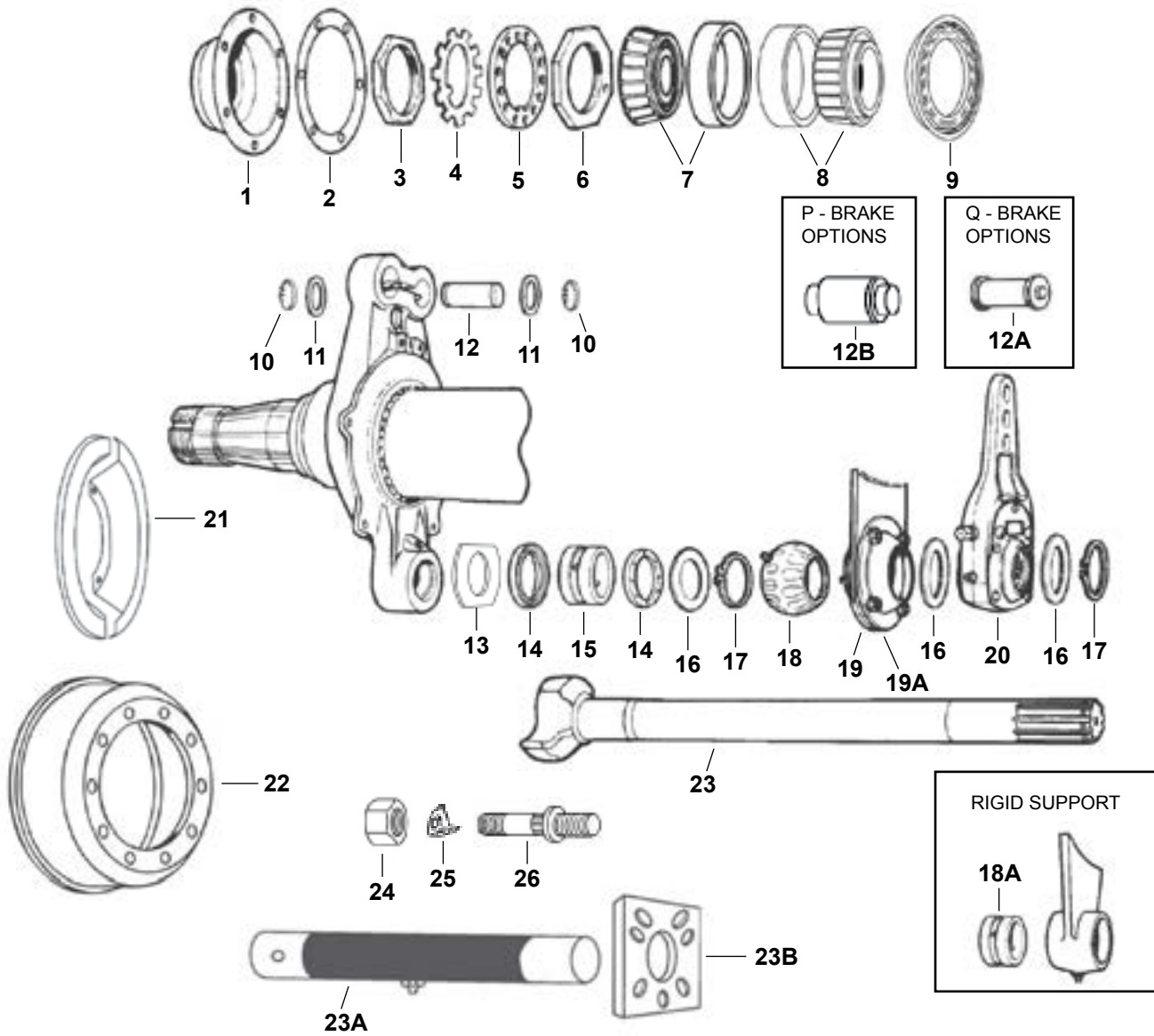

## "Q" TYPE BRAKE

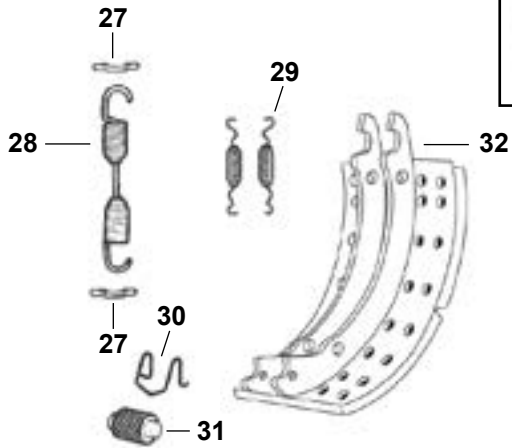

## "P" TYPE BRAKE

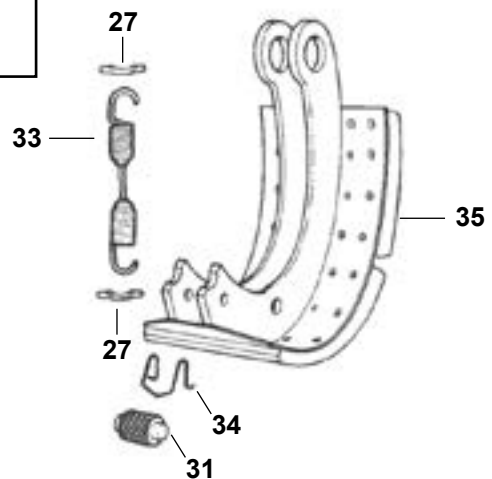

# FREIGHTER - INGERSOLL (IMT)

A22H / F22H AXLE  
16-1/2" X 7" BRAKES

ITEM NUMBER	PART NUMBER	DESCRIPTION
1	E-975	HUB CAP - GREASE
2	E-03009	HUB CAP GASKET - MULTI DRILLED 3, 5, 6 HOLE
3	E-572	OUTER AXLE SPINDLE NUT
4	E-2237	LOCK TAB WASHER
5	E-573	LOCK WASHER
6	E-540	INNER AXLE SPINDLE NUT
7	MERSET413	OUTER BEARING SET (HM212049/HM212011)
8	MERSET414	INNER BEARING SET (HM218248/HM218210)
9	MER0143	HUB SEAL
10	1229X1116	CIRCLIP - TO SUIT 1-1/4" SHAFT
11	E-1113	WASHER - 1-7/8" OD X 1-1/4" ID X 1/16"
12	1259M1131	ANCHOR PIN - STANDARD (CIRCLIP TYPE)
12A	-	BOLT ON ANCHOR PIN LONG (PART OF KITS E-8465AU / E-8466AU)
12B	1259N274	Q' BRAKE ANCHOR PIN
13	E-656	D' WASHER
14	E-1416	SEAL
15	E-759	OUTER CAM BUSH - NYLON
16	E-580	WASHER - 2.25" OD X 1.53" ID X0.06"
17	1229Z1118	CIRCLIP
18	E-2102	BUSH (D22-K22)
18A	E-661	INNER CAM BUSH - OLD STYLE WITH RIGID BRACKET
19	E-2104	CAM BUSH & BRACKET ASSEMBLY
19A	E-2365	RETAINER PLATE
20	E-612SBK	SLACK ADJUSTER - 3 HOLE, 10 SPLINE
21	E-886	BACKING PLATE (STEEL)
21	E-3775	BACKING PLATE (PLASTIC)
22	03-122222-002	BRAKE DRUM 11" PCD 9.44" SPIGOT 5 & 6 BOLT HOLES
23	E-1425A	S' CAM LH 10 SPLINE
23	E-1424A	S' CAM RH 10 SPLINE
23A	E-4737A	CAM ENCLOSURE
23B	E-4739	CAM ENCLOSURE PLATE
24	E-7775	WHEEL NUT
25	E-5571A	WHEEL CLAMP (FOR 5/6 SPOKE HUBS ONLY)
26	R004956A	WHEEL STUD

More Parts Next Page 



# FREIGHTER - INGERSOLL (IMT)

A22H / F22H AXLE  
16-1/2" X 7" BRAKES

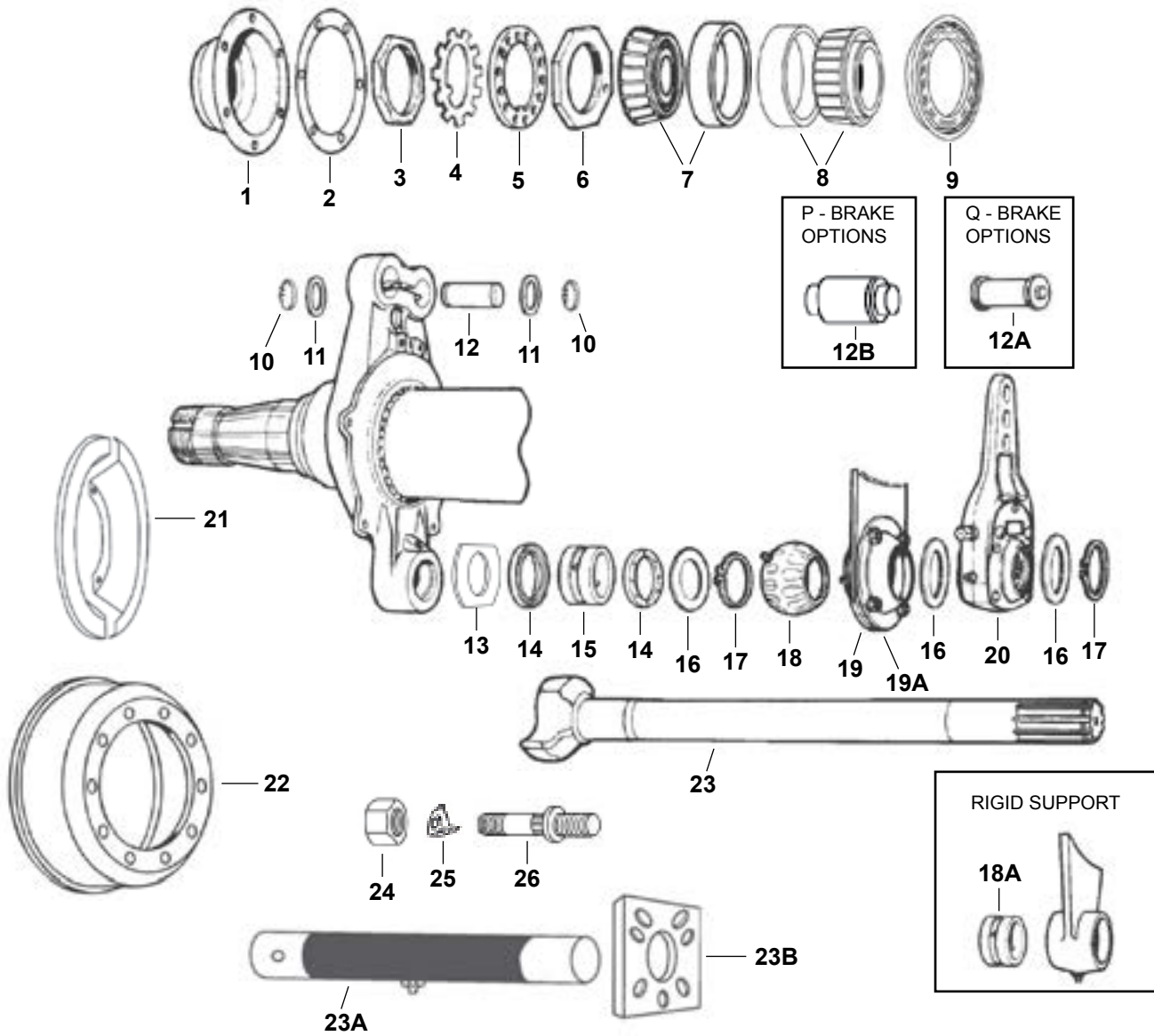

## "Q" TYPE BRAKE

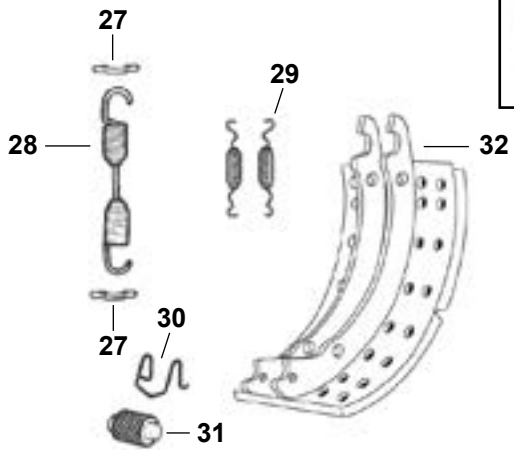

## "P" TYPE BRAKE

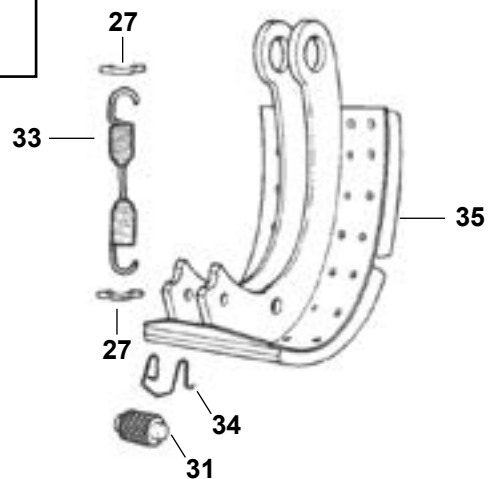

# FREIGHTER - INGERSOLL (IMT)

A22H / F22H AXLE  
16-1/2" X 7" BRAKES

ITEM NUMBER	PART NUMBER	DESCRIPTION
27	E-747	SPRING RETAINING PIN
28	2258W803	RETURN SPRING - 1 PER WHEEL 'Q' BRAKE
29	E-2767	RETAINING SPRING - 2 PER WHEEL, 'Q' BRAKE
30	3105B210	ROLLER RETAINER
31	2297T7222	ROLLER - SMOOTH
31	E-2177	ROLLER - KNURLED
31	E-2215	ROLLER - KNURLED 1/8" OVERSIZE
31	E-781	ROLLER - SMOOTH 1/8" OVERSIZE
31	E-586	ROLLER - SMOOTH 1/4" OVERSIZE
32	SMG2A4515Q	LINED BRAKE SHOE (NOT SOLD SEPARATELY - PART OF KITS EKSMG2A4515Q & KSMA2124515Q)
33	E-1880B	RETURN SPRING - 1 PER WHEEL P-BRAKE
34	E-539	ROLLER RETAINER
35	E-2241	UNLINED BRAKE SHOE - P TYPE
35	-	LINED BRAKE SHOE (NOT SOLD SEPARATELY - PART OF KIT EKSMG2A4515PHD)
36	-	CAM ROLLER RETAINER KIT (NOT SOLD SEPARATELY - PART OF KIT E-8465AU)

KIT	E-1816SHD	BRAKE KIT 'P' BRAKE WITH CIRCLIP ANCHOR PINS. ALL BRAKE HARDWARE KITS INCLUDE ENOUGH COMPONENTS TO SERVICE 1 WHEEL.
KIT	E-8466AU	BRAKE KIT 'P' BRAKE WITH LONG BOLT-ON ANCHOR PINS. ALL BRAKE HARDWARE KITS INCLUDE ENOUGH COMPONENTS TO SERVICE 1 WHEEL.
KIT	E-8465AU	BRAKE KIT 'P' BRAKE - SAME AS E-8466AU BUT SMOOTH ROLLERS. ALL BRAKE HARDWARE KITS INCLUDE ENOUGH COMPONENTS TO SERVICE 1 WHEEL.
KIT	KIT8000HD**	BRAKE KIT 'Q' BRAKE. INCLUDES ENOUGH COMPONENTS TO SERVICE 1 WHEEL.
KIT	E-2769HD	BRAKE KIT 'Q' BRAKE. INCLUDES ENOUGH COMPONENTS TO SERVICE 1 WHEEL.
KIT	E-2287	CAMSHAFT BUSH KIT. CAMSHAFT REPAIR KIT SERVICES 1 AXLE.
KIT	EKSMG2A4515PHD*	4515P - MAJOR BRAKE SHOE KIT - CONSISTS OF 2 LINED SHOES & HARDWARE KIT - SERVICES 1 WHEEL.
KIT	EKSMG2A4515PSS*	4515P - SHOE WITH WELDED WASHERS AND SMOOTH ROLLERS - MAJOR BRAKE SHOE KIT - CONSISTS OF 2 LINED SHOES & HARDWARE KIT - SERVICES 1 WHEEL.
KIT	EKSMG2A4515PSSK*	4515P - SHOE WITH WELDED WASHERS AND KNURLED ROLLERS - MAJOR BRAKE SHOE KIT - CONSISTS OF 2 LINED SHOES & HARDWARE KIT - SERVICES 1 WHEEL.
KIT	PKSMA2124515P**	4515-P MAJOR BRAKE SHOE KIT - CONSISTS OF 2 LINED SHOES & HARDWARE KIT - SERVICES 1 WHEEL.
KIT	PKSMA2124515PSS**	4515-P (WITH WELDED WASHER) MAJOR BRAKE SHOE KIT - CONSISTS OF 2 LINED SHOES & HARDWARE KIT - SERVICES 1 WHEEL.
KIT	EKSMG2A4515Q*	4515-Q MAJOR BRAKE SHOE KIT - CONSISTS OF 2 LINED SHOES & HARDWARE KIT - SERVICES 1 WHEEL.
KIT	KSMA2124515Q**	4515Q - MAJOR BRAKE SHOE KIT - CONSISTS OF 2 LINED SHOES & HARDWARE KIT - SERVICES 1 WHEEL.

\* Please contact Customer Service for details on other grades of friction material available.

\*\* Restricted sale.



# FRUEHAUF ROUND & I BEAM AXLE

16-1/2" x 7" BRAKES

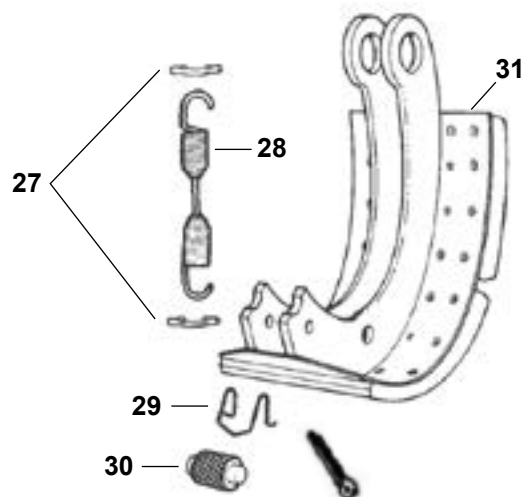
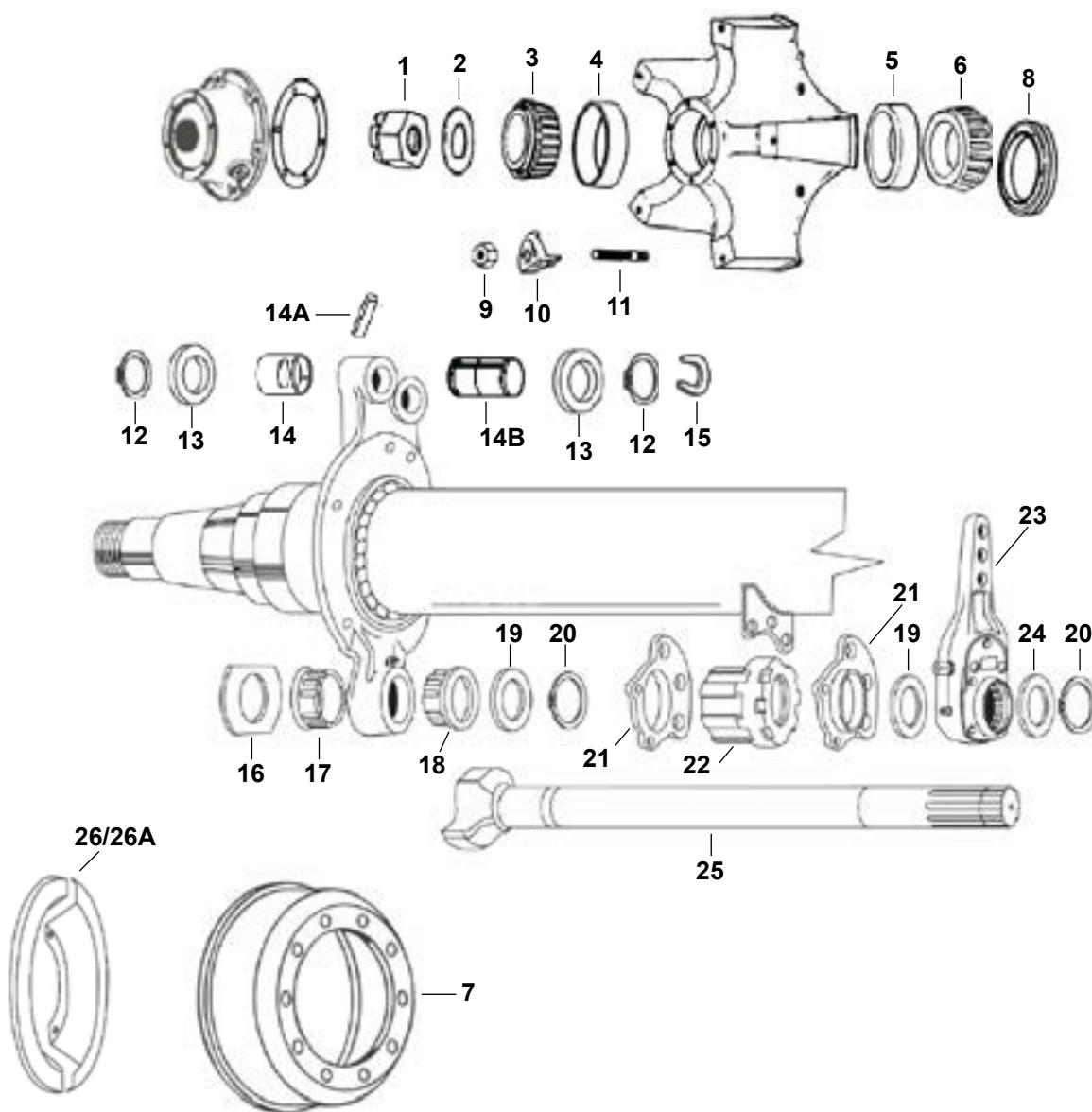



# FRUEHAUF ROUND & I BEAM AXLE

16-1/2" x 7" BRAKES

ITEM NUMBER	PART NUMBER	DESCRIPTION
1	E-576	CASTELLATED NUT
2	E-620	LOCK WASHER
3	HH506348	OUTER BEARING CONE
4	HH506310	OUTER BEARING CUP
5	592A	INNER BEARING CUP
6	593	INNER BEARING CONE
7	85-120586-002	BRAKE DRUM 11 1/4" PCD 9.50" SPIGOT 5 & 6 BOLT HOLES
8	MER0123	HUB SEAL
9	E-7775	WHEEL NUT
10	E-5571A	WHEEL CLAMP (FOR 5/6 SPOKE HUBS ONLY)
11	R004956A	WHEEL STUD
12	1229X1116	CIRCLIP - TO SUIT 1-1/4" SHAFT
13	E-1113	WASHER - 1-7/8" OD X 1-1/4" ID X 1/16"
14	1225U827	BUSH
14A	1199E1695	ROLL PIN
14B	E-1112A	ANCHOR PIN CIRCLIP TYPE
15	E-1106	CIRCLIP, 'C' TYPE, OPTIONAL
16	E-656	D' WASHER
17	E-943	BUSH (WHITE)
18	E-943	BUSH (YELLOW)
19	E-580	WASHER - 2.25" OD X 1.53" ID X0.06"
20	1229Z1118	CIRCLIP
21	E-603	RETAINER PLATE
22	E-535	BUSH
23	E-612SBK	SLACK ADJUSTER 1-1/2" - 10 SPLINE
24	1229Q771	WASHER FLAT
25	E-685	CAMSHAFT LH 10 SPLINE
25	E-684	CAMSHAFT RH 10 SPLINE
26	E-886	DUST COVER (STEEL)
26A	E-3775	DUST COVER (PLASTIC)
27	E-747	PIN
28	E-1880B	RETURN SPRING
29	E-539	ROLLER RETAINER

More Parts Next Page 

# FRUEHAUF ROUND & I BEAM AXLE

16-1/2" x 7" BRAKES

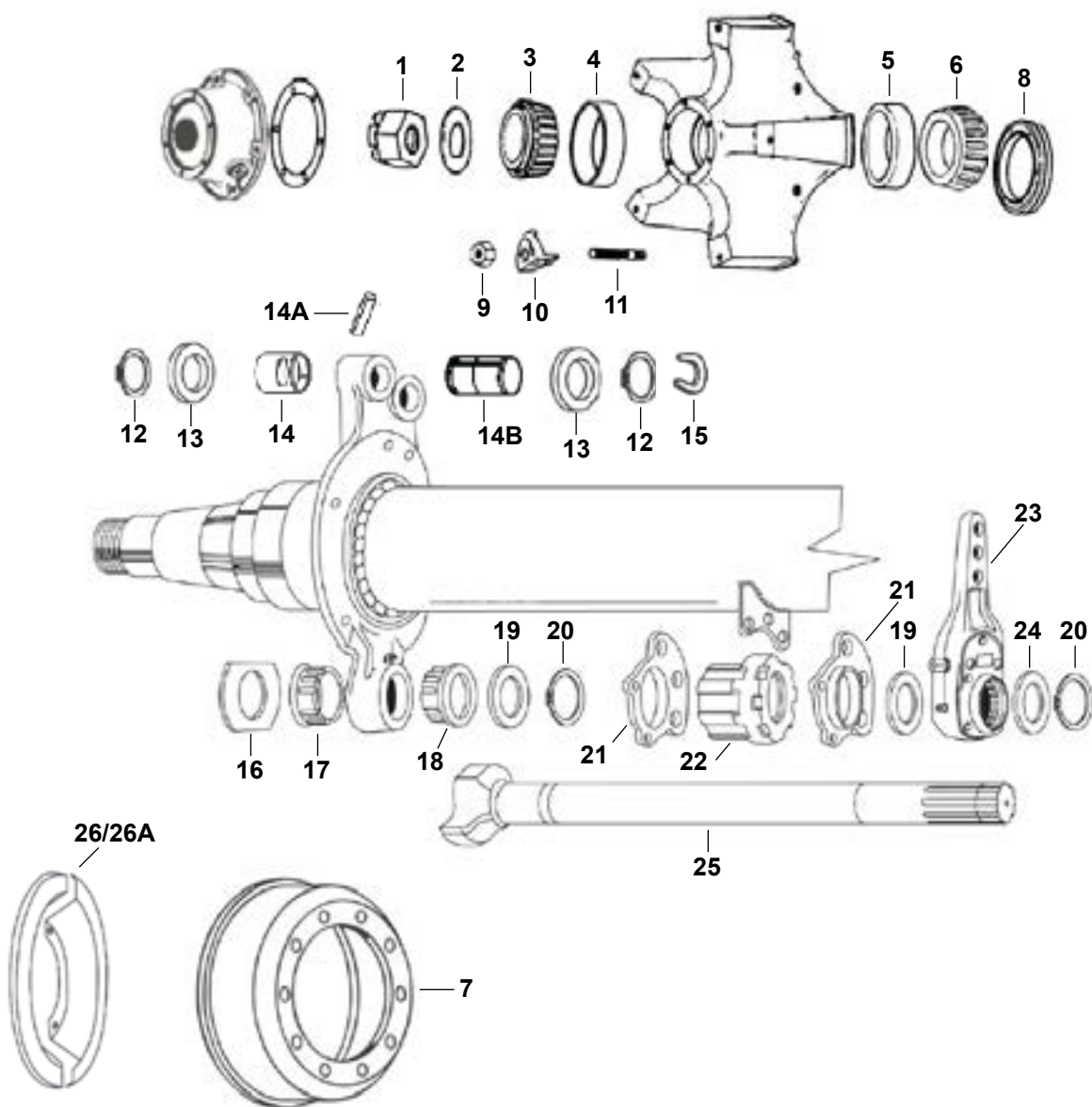

# FRUEHAUF ROUND & I BEAM AXLE

16-1/2" x 7" BRAKES

ITEM NUMBER	PART NUMBER	DESCRIPTION
30	2297T7222	ROLLER - SMOOTH
30	E-2177	ROLLER - KNURLED
30	E-2215	ROLLER - KNURLED 1/8" OVERSIZE
30	E-781	ROLLER - SMOOTH 1/8" OVERSIZE
30	E-586	ROLLER - SMOOTH 1/4" OVERSIZE
31	E-2685	UNLINED BRAKE SHOE (LINING REF. 4515E)
31	SMG2A4515F	LINED BRAKE SHOE (NOT SOLD SEPARATELY - PART OF KIT KSMA2124515F & EKSMG2A4515F)

KIT	E-1357A	CAMSHAFT BUSH KIT. CAMSHAFT REPAIR KIT SERVICES 1 AXLE.
KIT	E-1816SHD	BRAKE KIT 'P' BRAKE WITH CIRCLIP ANCHOR PINS.ALL BRAKE HARDWARE KITS INCLUDE ENOUGH COMPONENTS TO SERVICE 1 WHEEL.
KIT	KSMA2124515F**	4515 FRUEHAUF P TYPE - MAJOR BRAKE SHOE KIT - CONSISTS OF 2 LINED SHOES & HARDWARE KIT - SERVICES 1 WHEEL.
KIT	EKSMG2A4515F*	4515 FRUEHAUF P TYPE - MAJOR BRAKE SHOE KIT - CONSISTS OF 2 LINED SHOES & HARDWARE KIT - SERVICES 1 WHEEL.

\* Please contact Customer Service for details on other grades of friction material available.

\*\* Restricted sale.



# FRUEHAUF PROPAPR AXLE

16-1/2" x 7" BRAKES

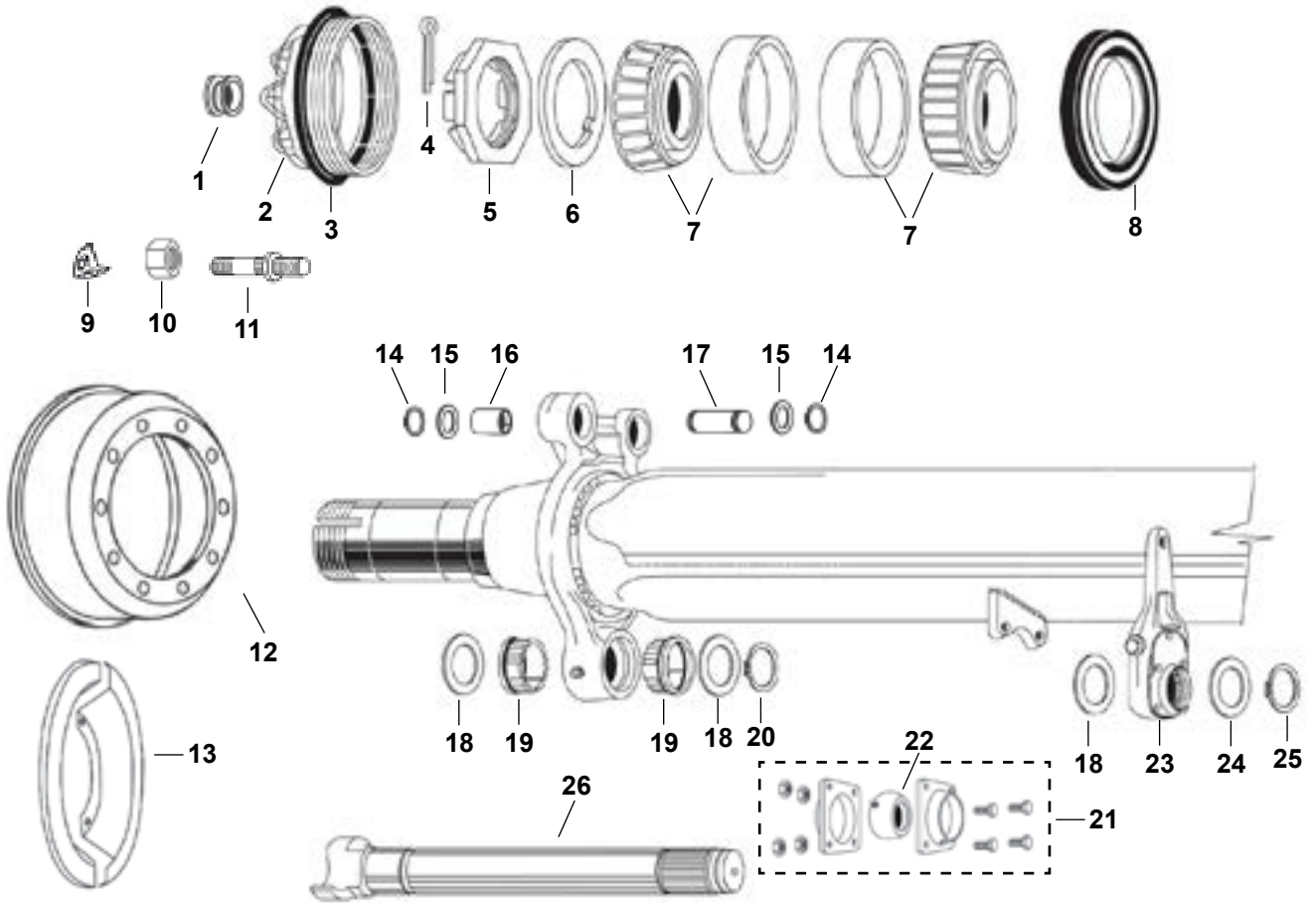

OLD STYLE "XEM" BRAKE

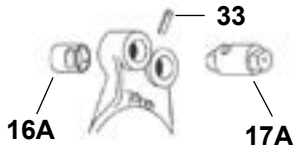

NEW "XEM" ANCHOR PIN HARDWARE



EARLY MODEL BUSH & BRACKET

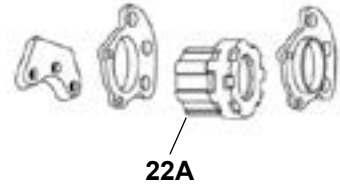

XEM "Q" TYPE BRAKE

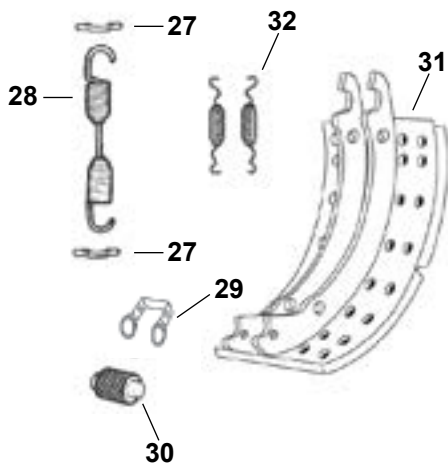

"P" TYPE BRAKE

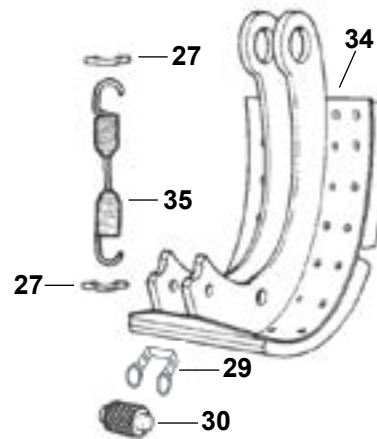

# FRUEHAUF PROPAG AXLE

16-1/2" x 7" BRAKES

ITEM NUMBER	PART NUMBER	DESCRIPTION
1	E-04000	HUB CAP PLUG
2	E-04075	HUB CAP
3	E-05500	HUB CAP 'O' RING
4	E-1559	SPLIT PIN
5	E-2550	CASTELLATED AXLE NUT
6	E-1561	WASHER
7	MERSET415	INNER/OUTER BRG SET (HM518445/HM518410)
8	MER0123	HUB WHEEL SEAL
9	E-5571A	WHEEL CLAMP (FOR 5/6 SPOKE HUBS ONLY)
10	E-7775	WHEEL NUT
11	R004956A	WHEEL STUD
12	85-120586-002	BRAKE DRUM 11 1/4" PCD 9.50" SPIGOT 5 & 6 BOLT HOLES
13	E-886	DUST COVER - STEEL
13	E-3775	DUST COVER - PLASTIC
14	1229X1116	CIRCLIP
15	E-1113	WASHER - 1.88" OD X 1.27" ID X 0.06" THICK
16	E-1893	ANCHOR PIN BUSH - STAINLESS STEEL
16A	1225U827	ANCHOR PIN BUSH (OLD STYLE XEM BRAKE)
17	1259Q251	ANCHOR PIN, P BRAKE, CIRCLIP
17A	E-2773	ANCHOR PIN XEM BRAKE - EARLY TO 1983
17B	E-3711	ANCHOR PIN XEM BRAKE - LATE FROM 1983
18	E-1565	WASHER - 2-3/8" OD X 1-5/8" ID X 1/16"
19	E-1567	BUSH, S-CAM SPIDER
20	E-1569	CAMSHAFT LOCK RING
21	E-4594	BUSH AND BRACKET KIT
22	E-1577A	INNER CAM BUSH, LATE TYPE
22A	E-1571	INNER CAM BUSH, EARLY TYPE
23	E-1574SBK	SLACK ADJUSTER - 3 HOLE, 37 SPLINE
24	E-580	WASHER
25	1229Z1118	CIRCLIP
26	E-2099	'S' CAM, LH - 21-1/8" / 537MM
26	E-2100	'S' CAM, RH - 21-1/8" / 537MM
26	E-1563	'S' CAM, LH - 16-1/8" / 410MM
26	E-1564	'S' CAM, RH - 16-1/8" / 410MM
26	E-3861	'S' CAM, LH - 23-7/8" / 606MM

More Parts Next Page 



# FRUEHAUF PROPAPR AXLE

16-1/2" x 7" BRAKES

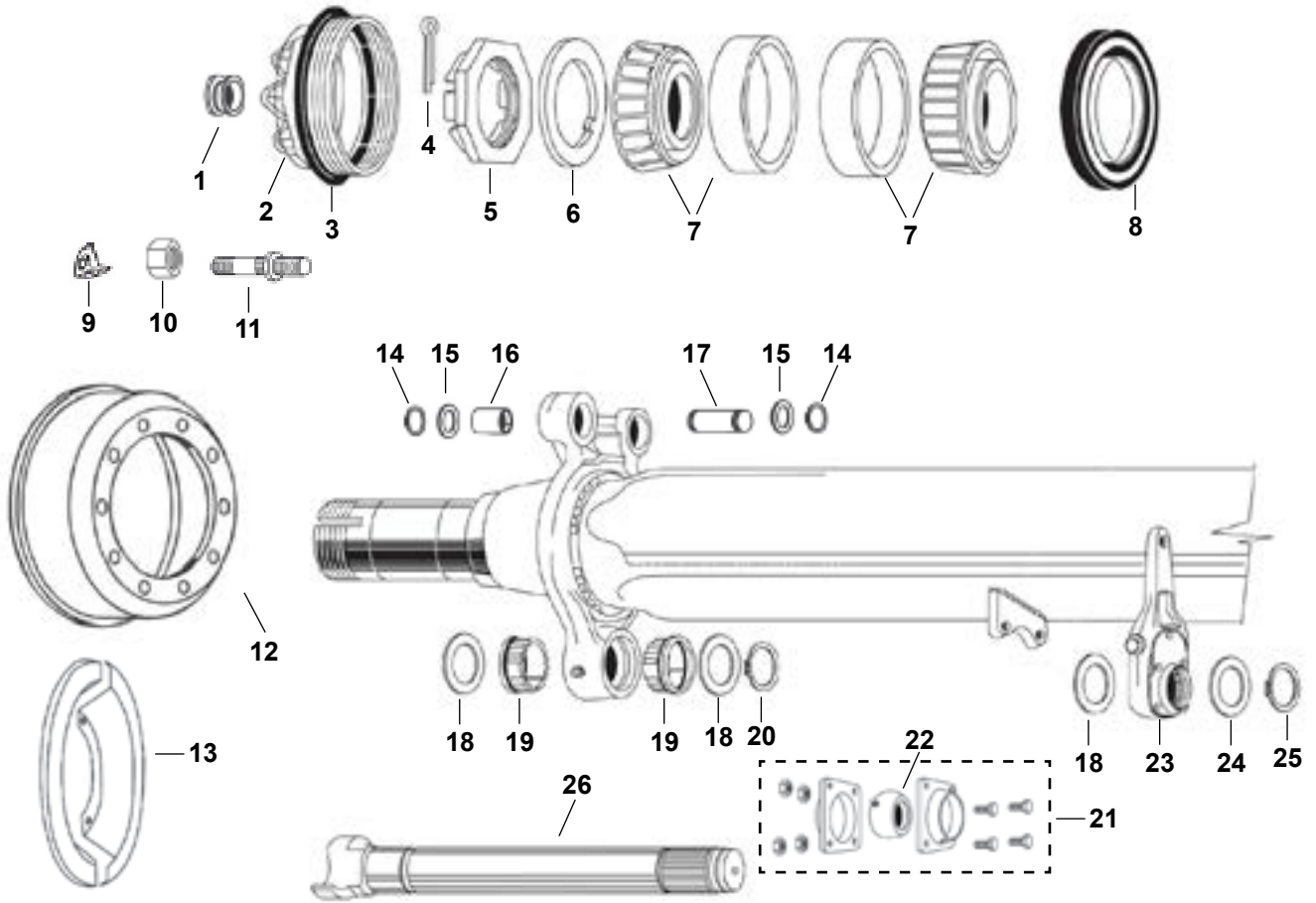

OLD STYLE "XEM" BRAKE

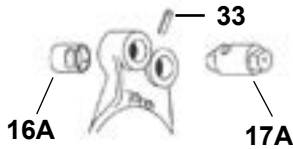

NEW "XEM" ANCHOR PIN HARDWARE



EARLY MODEL BUSH & BRACKET

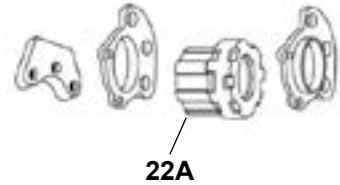

XEM "Q" TYPE BRAKE

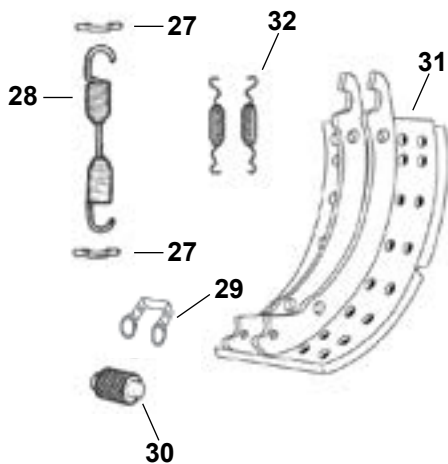

"P" TYPE BRAKE

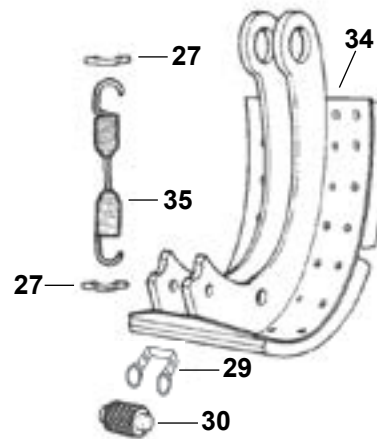

# FRUEHAUF PROPAG AXLE

16-1/2" x 7" BRAKES

ITEM NUMBER	PART NUMBER	DESCRIPTION
27	E-747	SPRING RETAINER
28	2258W803	RETURN SPRING, 1 PER XEM BRAKE
29	E-3227	ROLLER RETAINER
30	2297T7222	ROLLER - SMOOTH
30	E-2177	ROLLER - KNURLED
30	E-2215	ROLLER - KNURLED 1/8" OVERSIZE
30	E-781	ROLLER - SMOOTH 1/8" OVERSIZE
30	E-586	ROLLER - SMOOTH 1/4" OVERSIZE
31	SMG2A4515F3	LINED BRAKE SHOE (NOT SOLD SEPARATELY - PART OF KIT EKSMG2A4515F3)
32	E-2767	RETAINING SPRING - 2 PER XEM BRAKE
33	1199E1695	ROLL PIN
34	E-2685	UNLINED BRAKE SHOE (LINING REF. 4515E)
34	SMG2A4515F	LINED BRAKE SHOE (NOT SOLD SEPARATELY - PART OF KIT EKSMG2A4515F)
35	E-1880B	RETURN SPRING - 1 PER P-BRAKE

KIT	E-8466AU	BRAKE HARDWARE KIT FOR P SHOE WITH A WELDED WASHER (KNURLED ROLLER). SERVICES 1 WHEEL
KIT	E-8465AU	BRAKE HARDWARE KIT FOR P SHOE WITH A WELDED WASHER (SMOOTH ROLLER). SERVICES 1 WHEEL
KIT	R507008	BRAKE HARDWARE KIT QUICK RELEASE XEM SHOE. SERVICES 1 WHEEL
KIT	E-2122	CAMSHAFT REPAIR KIT SERVICES (EARLY TYPE) SERVICES 2 BRAKES
KIT	E-2090	CAMSHAFT REPAIR KIT (LATE TYPE WITH ROUND BUSH). SERVICES 2 BRAKES
KIT	EKSMG2A4515F3*	4515 F3 QUICK RELEASE MAJOR BRAKE SHOE KIT - CONSISTS OF 2 LINED SHOES & HARDWARE KIT - SERVICES 1 WHEEL.
KIT	EKSMG2A4515F*	4515 P TYPE SHOE. MAJOR BRAKE SHOE KIT - CONSISTS OF 2 LINED SHOES & HARDWARE KIT - SERVICES 1 WHEEL.

\* Please contact Customer Service for details on other grades of friction material available.

\*\* Restricted sale.



# FRUEHAUF PROPAPR AXLE

12-1/4" x 8" BRAKES

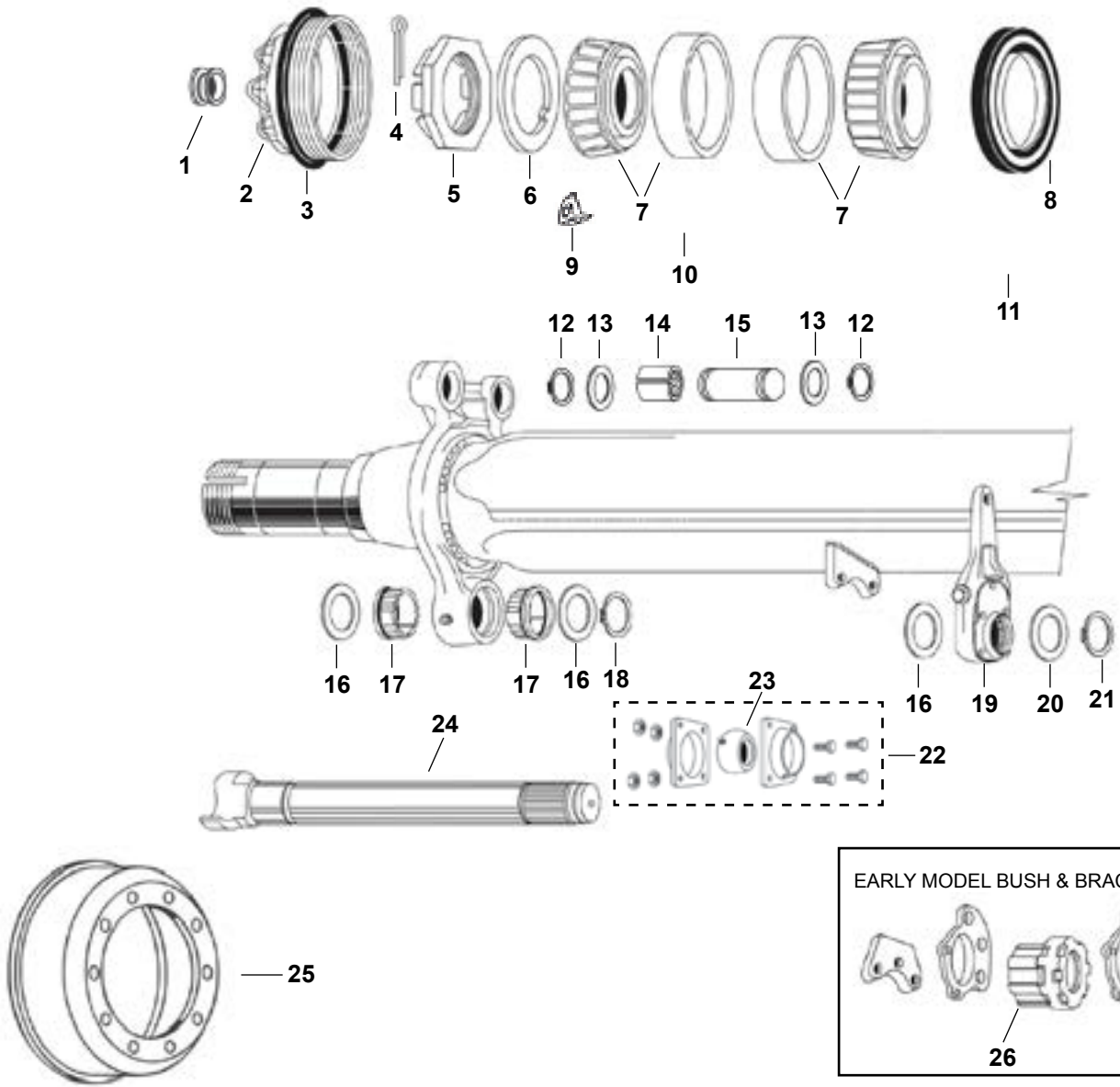

## "P" TYPE BRAKE

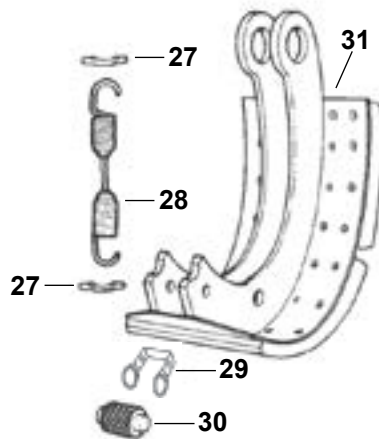



# FRUEHAUF PROPAG AXLE

12-1/4" x 8" BRAKES

ITEM NUMBER	PART NUMBER	DESCRIPTION
1	E-04000	HUB CAP PLUG
2	E-04075	HUB CAP
3	E-05500	HUB CAP 'O' RING
4	E-1559	SPLIT PIN
5	E-2550	CASTELLATED AXLE NUT
6	E-1561	WASHER
7	MERSET415	INNER/OUTER BRG SET (HM518445/HM518410)
8	MER0123	HUB WHEEL SEAL
9	E-7775	WHEEL NUT
10	E-5571A	WHEEL CLAMP (FOR 5/6 SPOKE HUBS ONLY)
11	R004956A	WHEEL STUD
12	1229X1116	CIRCLIP - TO SUIT 1 1/4" SHAFT
13	E-1113	WASHER - 1-7/8" OD X 1-1/4" ID X 1-1/16"
14	E-1893	ANCHOR PIN BUSH - STAINLESS STEEL
15	1259Q251	ANCHOR PIN, P BRAKE, CIRCLIP
16	E-1565	WASHER - 2-3/8" OD X 1-5/8" ID X 1/16"
17	E-1567	BUSH, S-CAM SPIDER
18	E-1569	CAMSHAFT LOCK RING
19	E-1574SBK	SLACK ADJUSTER - 3 HOLE, 37 SPLINE
20	E-580	WASHER - 2.25" OD X 1.53" ID X 0.06"
21	1229Z1118	CIRCLIP
22	E-4594	BUSH AND BRACKET KIT
23	E-1577A	INNER CAM BUSH, LATE TYPE
24	E-4890	'S' CAM, LH - 21 3/16" (538MM)
24	E-4891	'S' CAM, RH - 21 3/16" (538MM)
25	03-122963-002	BRAKE DRUM, 8-1/2" SPIGOT / 10" PCD
25	03-122971-002	BRAKE DRUM, 7-1/4" SPIGOT / 8-1/4" PCD
26	E-1571	INNER CAM BUSH, EARLY TYPE
27	E-747	SPRING RETAINER
28	E-1583	RETURN SPRING - 1 PER WHEEL
29	E-1581	ROLLER RETAINER
30	E-1582	ROLLER
31	E-1580	UNLINED BRAKE SHOE (LINING REF. 4649)

More Parts Next Page 



# FRUEHAUF PROPAG AXLE

12-1/4" x 8" BRAKES

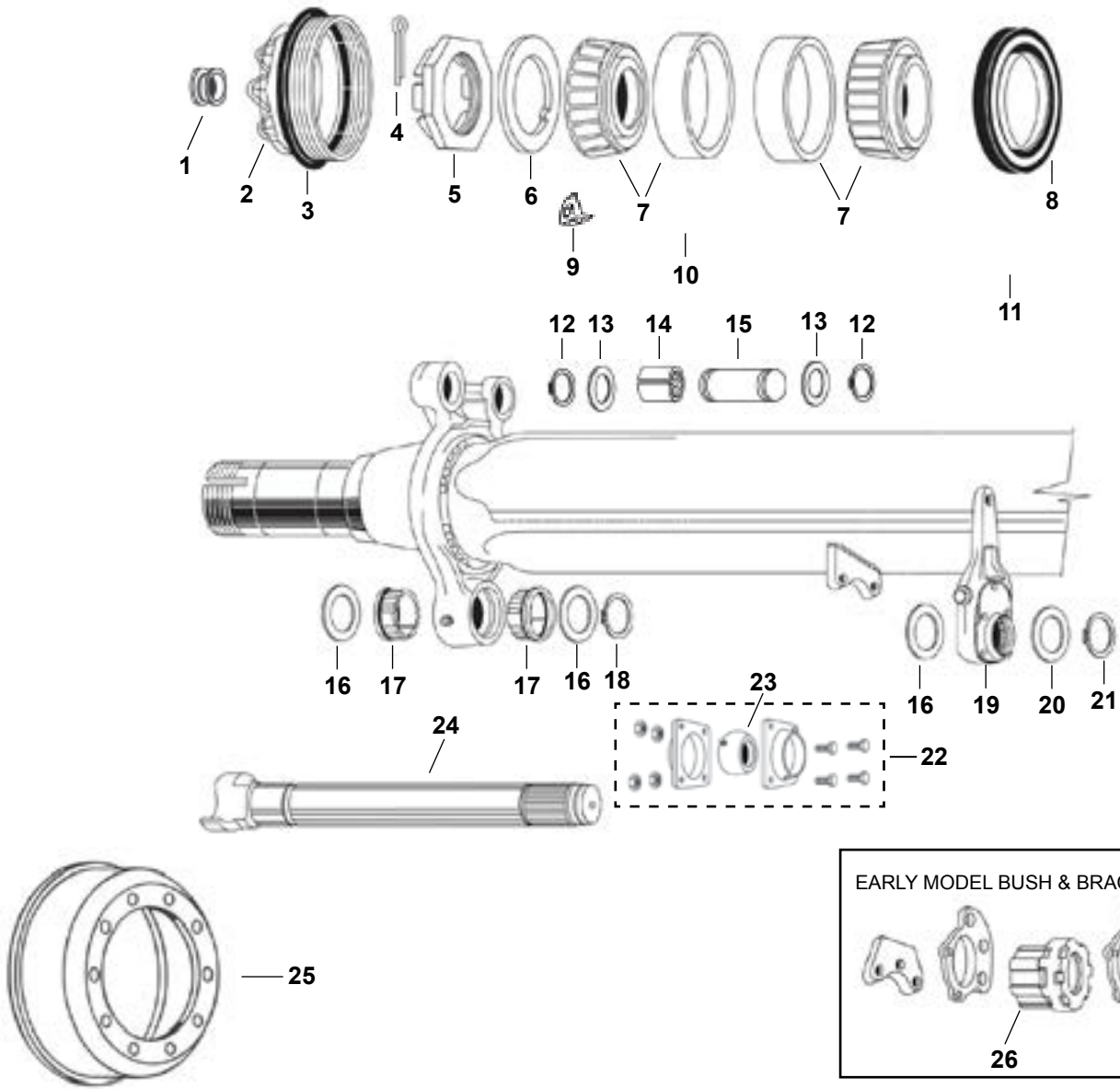

## "P" TYPE BRAKE

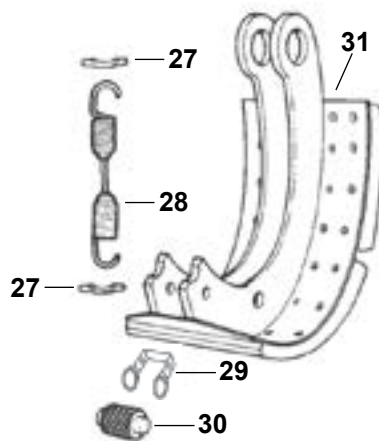

# FRUEHAUF PROPAG AXLE

12-1/4" x 8" BRAKES

ITEM NUMBER	PART NUMBER	DESCRIPTION
KIT	E-2122	CAMSHAFT BUSH KIT (EARLY TYPE). CAMSHAFT REPAIR KIT SERVICES 1 CAMSHAFT. CAMSHAFT BUSH KIT SERVICES 1 AXLE.
KIT	E-2090	CAMSHAFT BUSH KIT (LATE TYPE WITH ROUND BUSH). CAMSHAFT REPAIR KIT SERVICES 1 CAMSHAFT. CAMSHAFT BUSH KIT SERVICES 1 AXLE.
KIT	E-2773	ANCHOR PIN XEM BRAKE - EARLY TO 1983
KIT	E-3711	ANCHOR PIN XEM BRAKE - LATE FROM 1983

\* Please contact Customer Service for details on other grades of friction material available.

\*\* Restricted sale.



# HENDRICKSON INTRAAX TRAILER AXLE

16-1/2" X 7 / 16-1/2" X 8-5/8" BRAKES

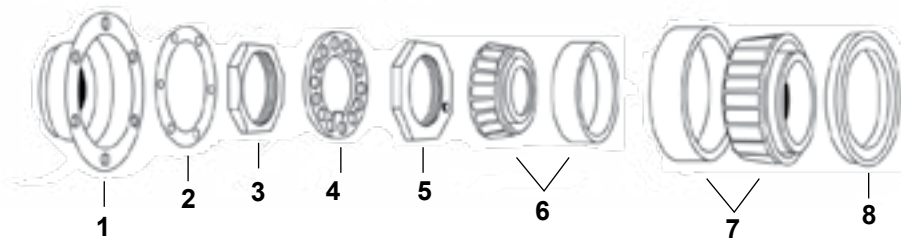

**Camshaft, Bushings & Bracket Parts  
New Style, Enclosed Cam Tube**

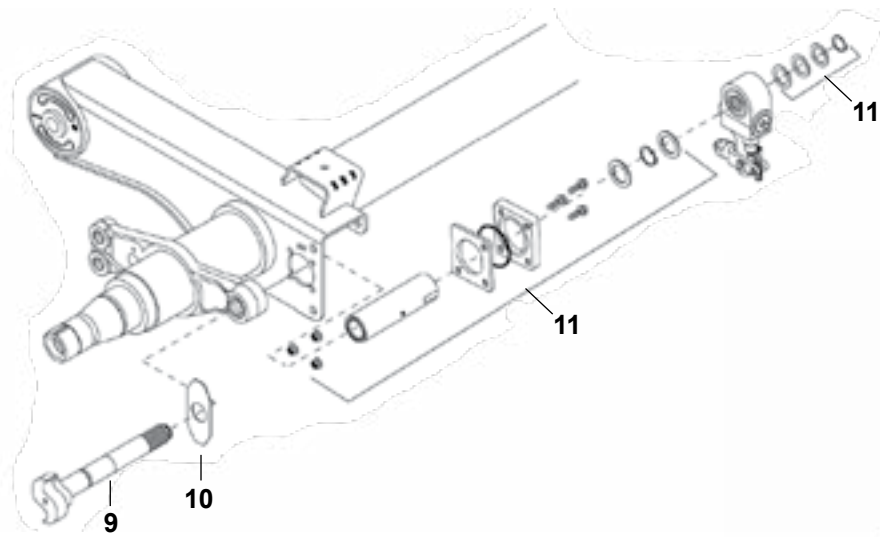

**Camshaft, Bushings & Bracket Parts  
Old Style, Exposed Cam Tube**

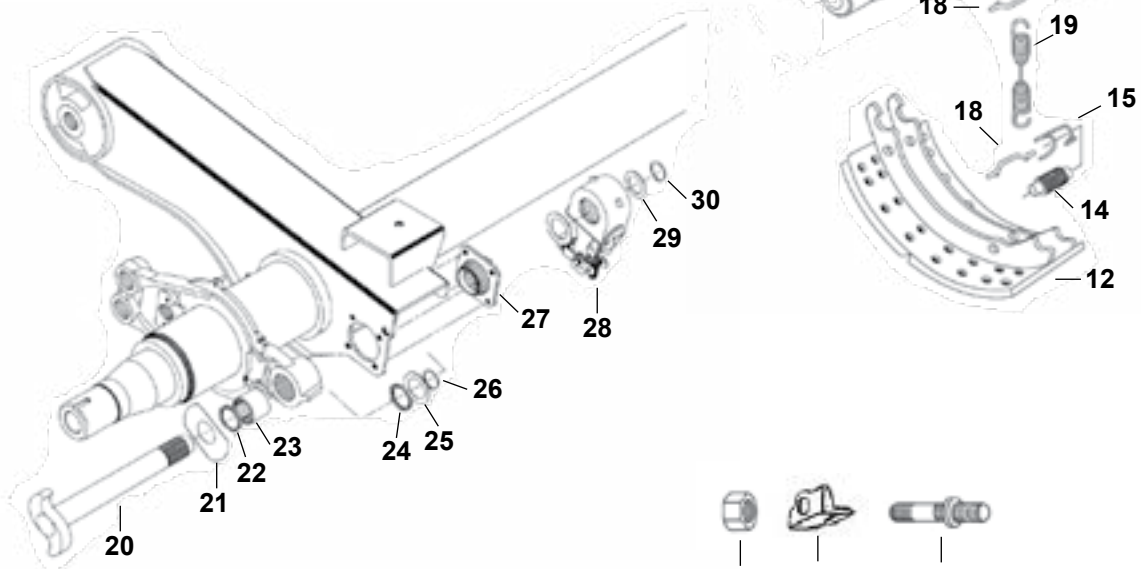

# HENDRICKSON INTRAAX TRAILER AXLE

16-1/2" X 7 / 16-1/2" X 8-5/8" BRAKES

ITEM NUMBER	PART NUMBER	DESCRIPTION
1	E-975	HUB CAP
2	E-03009	GASKET - HUB CAP
3	E-1251	OUTER SPINDLE NUT
4	E-1252	LOCK WASHER
5	E-2128	INNER SPINDLE NUT
6	MERSET413	OUTER BEARING SET (HM212049/HM212011)
7	MERSET414	INNER BEARING SET (HM218248/HM218210)
8	MER0143	HUB SEAL
9	E-10900	CAMSHAFT RH
9	E-10899	CAMSHAFT LH
10	-	D' WASHER (NOT SOLD SEPARATELY - PART OF KIT E-11897)
11	E-11897	CAMSHAFT TUBE REPAIR KIT. CAMSHAFT BUSH / TUBE KIT SERVICES 1 AXLE.
12	R4515	UNLINED BRAKE SHOE - STANDARD (4515)
12	SMG2A4515Q	LINED BRAKE SHOE - NOT SOLD SEPARATELY - PART OF KIT EKSMG2A4515Q)
12	4711XT	UNLINED BRAKE SHOE - HXS (4711)
12	SMG2A4711QP	LINED BRAKE SHOE (NOT SOLD SEPARATELY - PART OF KIT EKSMG2A4711QP)
12	R4707	UNLINED BRAKE SHOE - HXS (4707)
12	SMG2A4707QP	LINED BRAKE SHOE (NOT SOLD SEPARATELY - PART OF KIT EKSMG2A4707QP)
13	E-2767	RETAINING SPRING - 'Q' BRAKE, 2 PER WHEEL
14	2297T7222	ROLLER - SMOOTH
14	E-2177	ROLLER - KNURLED
14	E-2215	ROLLER - KNURLED 1/8" OVERSIZE
14	E-781	ROLLER - SMOOTH 1/8" OVERSIZE
14	E-586	ROLLER - SMOOTH 1/4" OVERSIZE
15	E-539	ROLLER RETAINER
16	E-1893	ANCHOR PIN BUSH - STAINLESS STEEL
17	1259N274	Q' BRAKE ANCHOR PIN
18	E-747	SPRING RETAINER
19	2258W803	RETURN SPRING - 'Q' BRAKE, 1 PER WHEEL
20	E-11867	CAMSHAFT RH
20	E-11866	CAMSHAFT LH
21	E-656	D' WASHER

More Parts Next Page 



# HENDRICKSON INTRAAX TRAILER AXLE

16-1/2" X 7 / 16-1/2" X 8-5/8" BRAKES

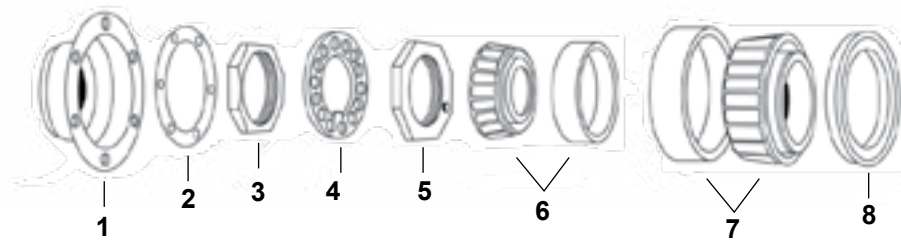

Camshaft, Bushings & Bracket Parts  
New Style, Enclosed Cam Tube

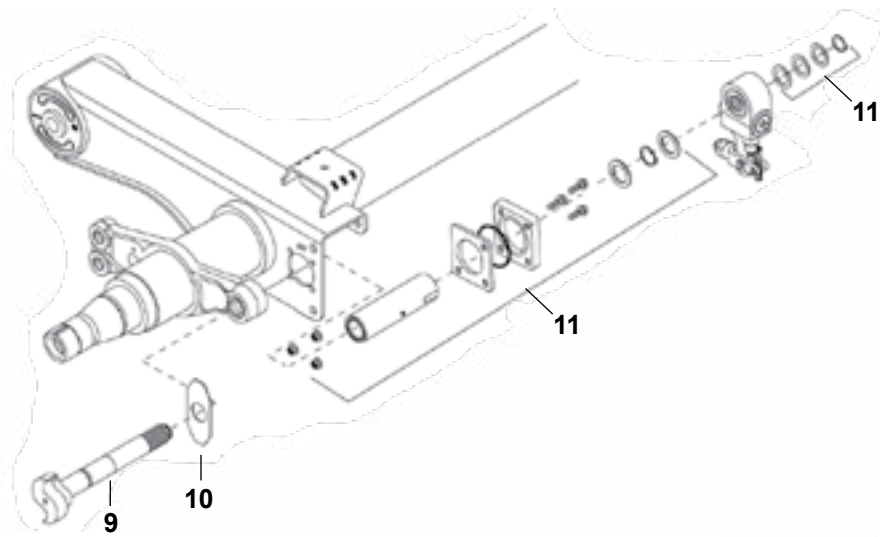

Camshaft, Bushings & Bracket Parts  
Old Style, Exposed Cam Tube

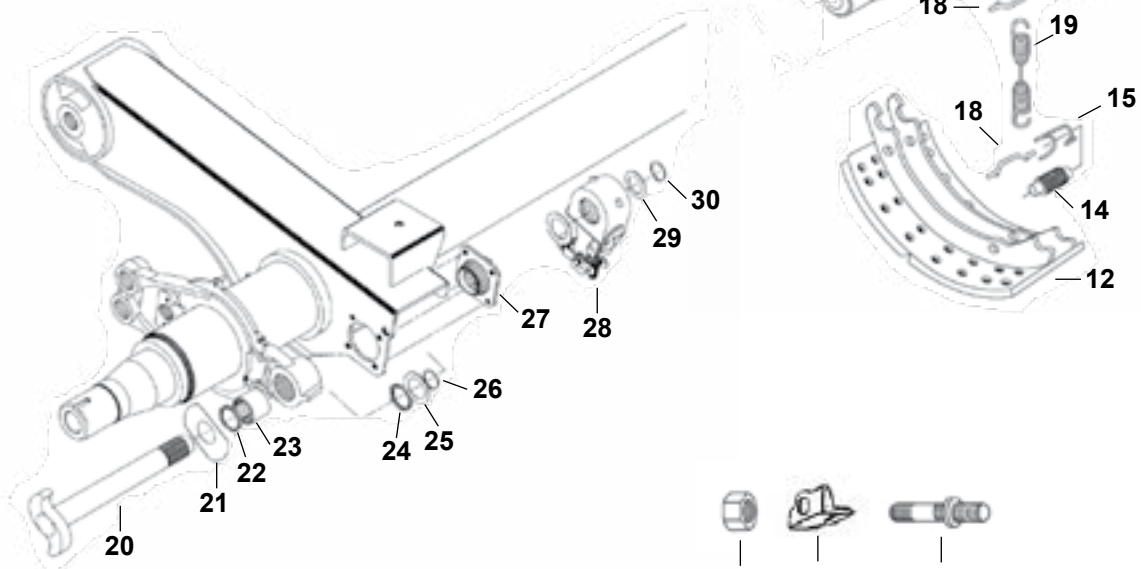

# HENDRICKSON INTRAAX TRAILER AXLE

16-1/2" X 7 / 16-1/2" X 8-5/8" BRAKES

ITEM NUMBER	PART NUMBER	DESCRIPTION
22	E-1416	SEAL
22	E-2717	SEAL 2.00"
23	E-11449	BRONZE CAM BUSH 2.00"
23	E-807	BRONZE CAM BUSH 1.875"
24	E-1416	SEAL
25	E-719	SPACER WASHER - 2-3/8" OD X 1-5/8" ID X 1/16"
26	E-2720	CIRCLIP
27	E-1318A	BRACKET & BUSH ASSEMBLY
28	E-2458-SBK	SLACK ADJUSTER 28 SPLINE
29	E-1113	SPACER WASHER - 1-7/8" OD X 1-7/16" X 1/16"
30	1229Q2851	CIRCLIP
31	E-7775	WHEEL NUT
32	E-5571A	WHEEL CLAMP (FOR 5/6 SPOKE HUBS ONLY)
33	R004956A	WHEEL STUD

KIT	KIT8000HD**	BRAKE KIT, INCLUDES ITEMS 13, 14, 15, 16, 17 ,18 &19. INCLUDES ENOUGH COMPONENTS TO SERVICE 1 WHEEL.
KIT	E-2769HD	BRAKE KIT, INCLUDES ITEMS 13, 14, 15, 16, 17 ,18 &19. INCLUDES ENOUGH COMPONENTS TO SERVICE 1 WHEEL.
KIT	E-9791HD	CAMSHAFT BUSH KIT WITH 1-7/8" BUSHES AND SEALS. CAMSHAFT BUSH / TUBE KIT SERVICES 1 AXLE.
KIT	E-11450	CAMSHAFT BUSH KIT WITH 2" BUSHES AND SEALS. CAMSHAFT BUSH / TUBE KIT SERVICES 1 AXLE.
KIT	EKSMG2A4515Q*	4515Q - MAJOR BRAKE SHOE KIT - CONSISTS OF 2 LINED SHOES & HARDWARE KIT - SERVICES 1 WHEEL.
KIT	EKSMG2A4711QP*	4711QP - MAJOR BRAKE SHOE KIT - CONSISTS OF 2 LINED SHOES & HARDWARE KIT - SERVICES 1 WHEEL.
KIT	EKSMG2A4707QP*	4707QP - MAJOR BRAKE SHOE KIT - CONSISTS OF 2 LINED SHOES & HARDWARE KIT - SERVICES 1 WHEEL.
KIT	PKSMA2124515Q**	4515Q - MAJOR BRAKE SHOE KIT - CONSISTS OF 2 LINED SHOES & HARDWARE KIT - SERVICES 1 WHEEL.
KIT	KSMA2124711QP**	4711QP - MAJOR BRAKE SHOE KIT - CONSISTS OF 2 LINED SHOES & HARDWARE KIT - SERVICES 1 WHEEL.
KIT	KSMA2124707QP**	4707QP - MAJOR BRAKE SHOE KIT - CONSISTS OF 2 LINED SHOES & HARDWARE KIT - SERVICES 1 WHEEL.

\* Please contact Customer Service for details on other grades of friction material available.

\*\* Restricted sale.



# HOLLAND P SERIES TRAILER AXLE

PRO-PAR PARALLEL BEARINGS

16-1/2" x 7" BRAKES

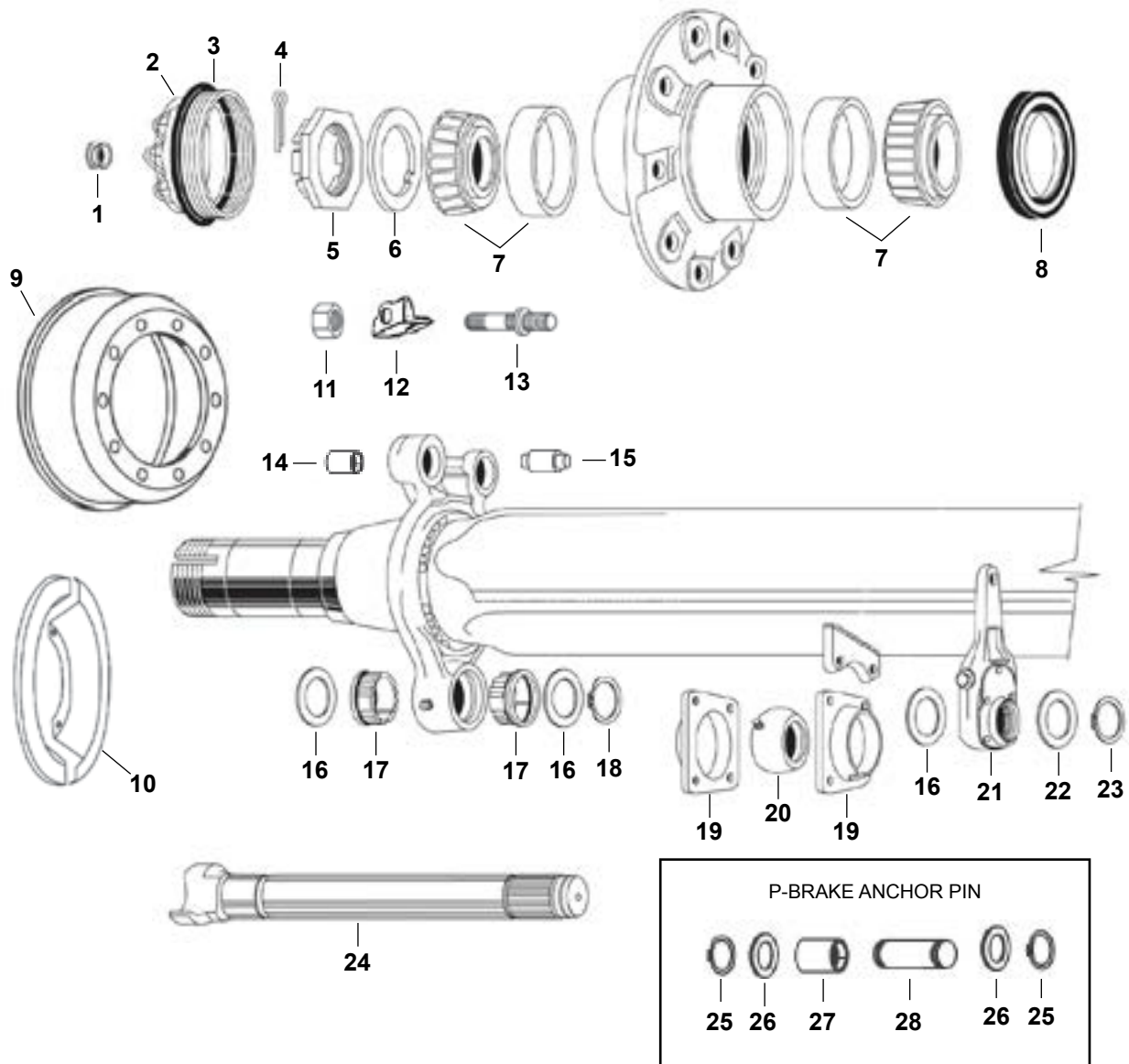

## XEM "Q" TYPE BRAKE

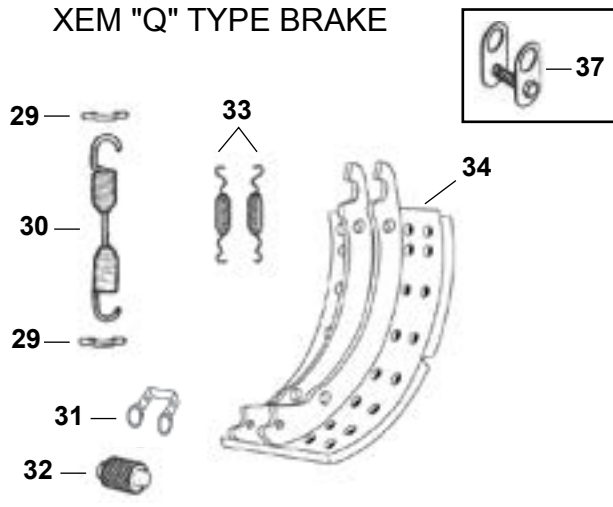

## "P" TYPE BRAKE

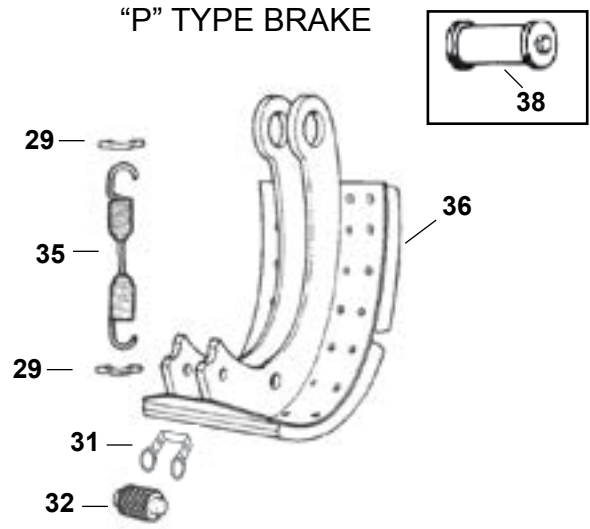



# HOLLAND P SERIES TRAILER AXLE

PRO-PAR PARALLEL BEARINGS  
16-1/2" x 7" BRAKES

ITEM NUMBER	PART NUMBER	DESCRIPTION
1	E-04000	HUB CAP PLUG
2	E-04075	HUB CAP
3	E-05500	HUB CAP 'O' RING
4	E-1559	SPLIT PIN
5	E-2550	CASTELLATED AXLE NUT
6	E-1561	WASHER
7	MERSET415	INNER/OUTER BRG SET (HM518445/HM518410)
8	MER0123	HUB WHEEL SEAL
9	85-120586-002	BRAKE DRUM 11 1/4" PCD 9.50" SPIGOT 5 & 6 BOLT HOLES
10	E-886	DUST COVER - STEEL
10A	E-3775	DUST COVER - PLASTIC
11	E-7775	WHEEL NUT
12	E-5571A	WHEEL CLAMP (FOR 5/6 SPOKE HUBS ONLY)
13	R004956A	WHEEL STUD
14	E-1893	ANCHOR PIN BUSH - STAINLESS STEEL
14A	1225B496	ANCHOR PIN BUSH - BRONZE LINED
15	E-3711	ANCHOR PIN, XEM BRAKE
16	E-1565	CAMS SHAFT SAPCER WASHER
17	E-1567	BUSH, S-CAM SPIDER
18	E-1569	CAMSHAFT LOCK RING
19	E-4594	BUSH AND BRACKET KIT
20	E-1577A	INNER CAM BUSH, LATE TYPE
21	E-1574SBK	SLACK ADJUSTER 1 5/8" - 37 SPLINE (3 HOLES)
22	E-580	WASHER - 2.25" OD X 1.53" ID X 0.06"
23	1229Z1118	CIRCLIP
24	E-3861	'S' CAM, LH - 23-7/8" / 606MM
24	E-3862	'S' CAM, RH - 23-7/8" / 606MM
25	1229X1116	CIRCLIP - TO SUIT 1-1/4" SHAFT
26	E-1113	WASHER
27	E-1893	ANCHOR PIN BUSH - STAINLESS STEEL

More Parts Next Page 



# HOLLAND P SERIES TRAILER AXLE

PRO-PAR PARALLEL BEARINGS

16-1/2" x 7" BRAKES

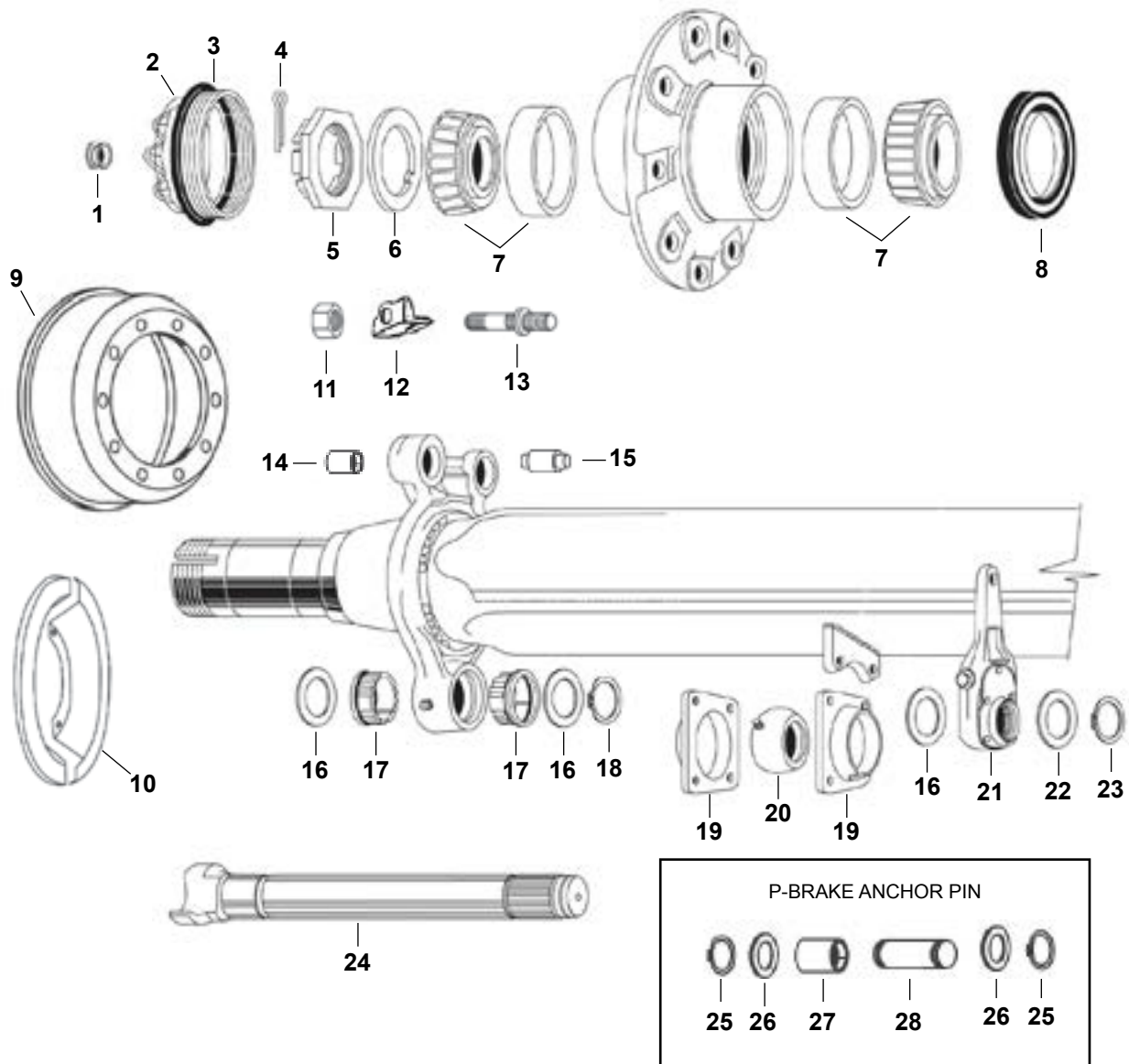

## XEM "Q" TYPE BRAKE

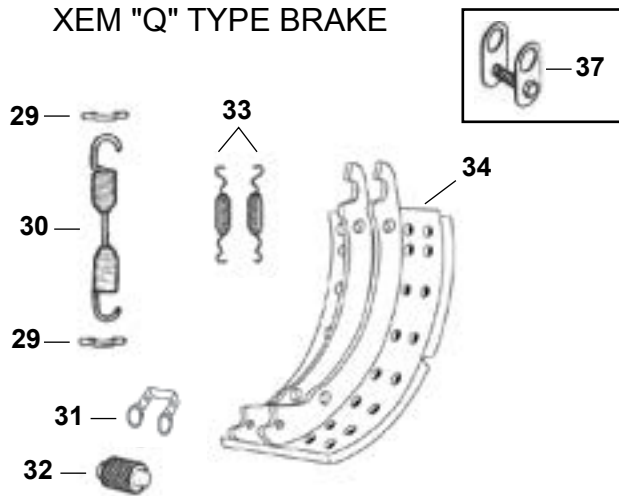

## "P" TYPE BRAKE

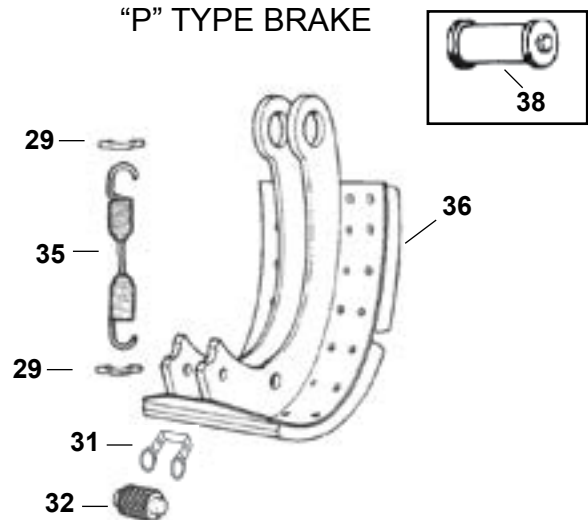

# HOLLAND P SERIES TRAILER AXLE

PRO-PAR PARALLEL BEARINGS  
16-1/2" x 7" BRAKES

ITEM NUMBER	PART NUMBER	DESCRIPTION
28	E-1112A	ANCHOR PIN - STANDARD
29	E-747	SPRING RETAINER
30	2258W803	RETURN SPRING - 1 PER XEM BRAKE
31	E-3227	CAM ROLLER RETAINER
32	2297T7222	ROLLER - SMOOTH
32	E-2177	ROLLER - KNURLED
32	E-781	ROLLER - SMOOTH 1/8" OVERSIZE
32	E-586	ROLLER - SMOOTH 1/4" OVERSIZE
33	E-2767	RETAINING SPRING - 2 PER XEM BRAKE
34	SMA2124515F3	LINED BRAKE SHOE (NOT SOLD SEPARATELY - PART OF KIT KSMA2124515F3)
34	SMG2A4515F3	LINED BRAKE SHOE (NOT SOLD SEPARATELY - PART OF KIT EKSMG2A4515F3)
35	E-1880B	RETURN SPRING - 1 PER P-BRAKE
36	SMG2A4515F	LINED BRAKE SHOE (NOT SOLD SEPARATELY - PART OF KITS EKSMG2A4515F & KSMA2124515F)
37	-	BOLT ON TYPE CAM ROLLER RETAINER (NOT SOLD SEPARATELY - PART OF KITS E-8465AU & E-8466AU)
38	-	ANCHOR PIN BOLT ON TYPE LONG (NOT SOLD SEPARATELY - PART OF KITS E-8465AU & E-8466AU)

KIT	E-1816SHD	BRAKE HARDWARE KIT 'P' BRAKE WITH CIRCLIP ANCHOR PINS.
KIT	E-8466AU	BRAKE HARDWARE KIT 'P' BRAKE WITH LONG BOLT-ON ANCHOR PINS WITH KNURLED ROLLERS
KIT	E-8465AU	BRAKE HARDWARE KIT 'P' BRAKE - SAME AS E-8466AU BUT SMOOTH ROLLERS
KIT	R507008	BRAKE KIT XEM BRAKE. ALL BRAKE HARDWARE KITS INCLUDE ENOUGH COMPONENTS TO SERVICE 1 WHEEL.
KIT	E-2090	CAMSHAFT REPAIR KIT. COMPONENTS SUFFICE 1 AXLE (2 BRAKES)
KIT	KSMA2124515F3**	4515 XEM Q TYPE - MAJOR BRAKE SHOE KIT - CONSISTS OF 2 LINED SHOES & HARDWARE KIT - SERVICES 1 WHEEL.
KIT	EKSMG2A4515F3*	4515 XEM Q TYPE - MAJOR BRAKE SHOE KIT - CONSISTS OF 2 LINED SHOES & HARDWARE KIT - SERVICES 1 WHEEL.
KIT	EKSMG2A4515F*	4515 FRUEHAUF P TYPE - MAJOR BRAKE SHOE KIT - CONSISTS OF 2 LINED SHOES & HARDWARE KIT - SERVICES 1 WHEEL.
KIT	KSMA2124515F**	4515 FRUEHAUF P TYPE - MAJOR BRAKE SHOE KIT - CONSISTS OF 2 LINED SHOES & HARDWARE KIT - SERVICES 1 WHEEL.

\* Please contact Customer Service for details on other grades of friction material available.

\*\* Restricted sale.



# HOLLAND T SERIES TRAILER AXLE

TAPERED BEARINGS  
16-1/2" x 7" BRAKES

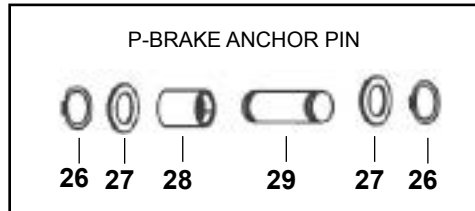
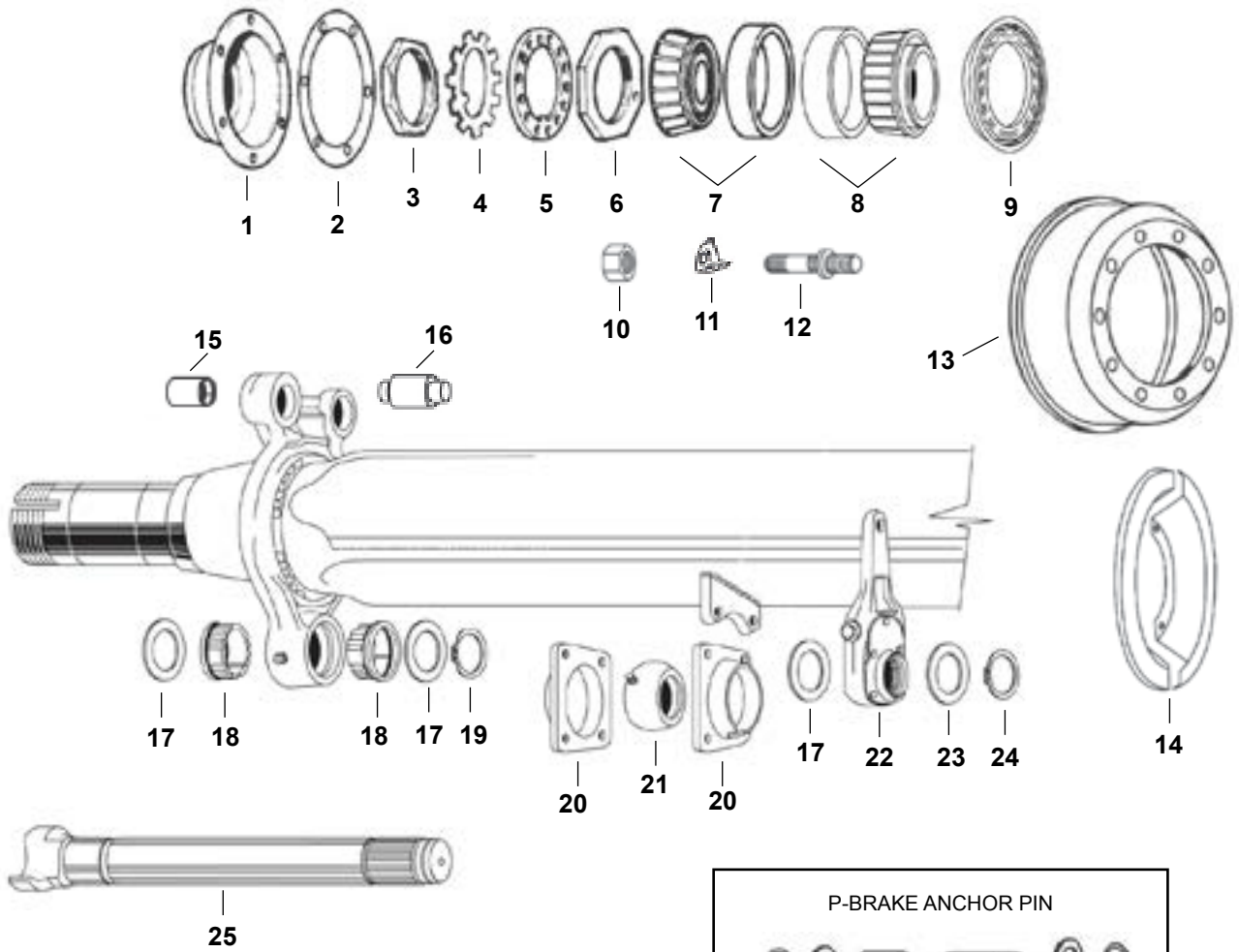

## XEM "Q" TYPE BRAKE

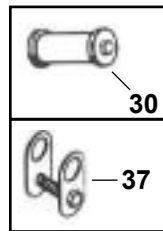
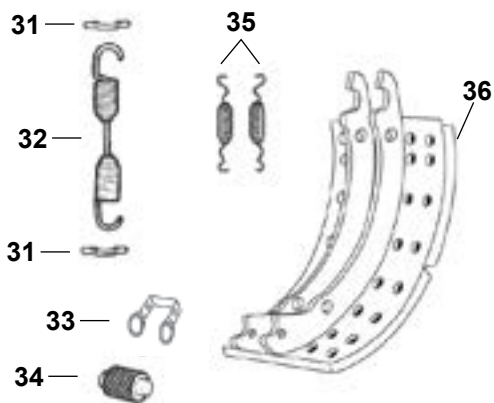

## "P" TYPE BRAKE

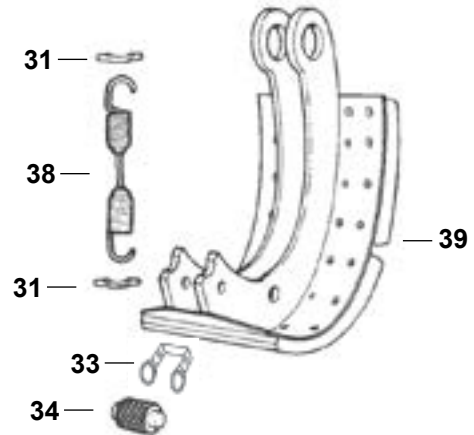

# HOLLAND T SERIES TRAILER AXLE

TAPERED BEARINGS  
16-1/2" x 7" BRAKES

ITEM NUMBER	PART NUMBER	DESCRIPTION
1	E-975	HUB CAP
2	E-03009	GASKET - HUB CAP
3	E-572	OUTER AXLE SPINDLE NUT
4	E-2237	TAB WASHER
5	E-573	LOCK WASHER
6	E-540	INNER AXLE SPINDLE NUT
7	MERSET413	OUTER BEARING SET (HM212049/HM212011)
8	MERSET414	INNER BEARING SET (HM218248/HM218210)
9	MER0143	HUB SEAL
10	E-7775	WHEEL NUT
11	E-5571A	WHEEL CLAMP (FOR 5/6 SPOKE HUBS ONLY)
12	R004956A	WHEEL STUD
13	03-122222-002	BRAKE DRUM 11" PCD 9.44" SPIGOT 5 & 6 BOLT HOLES
14	E-886	DUST COVER (STEEL)
14	E-3775	DUST COVER (PLASTIC)
15	E-1893	ANCHOR PIN BUSH - STAINLESS STEEL
15A	1225B496	ANCHOR PIN BUSH - BRONZE LINED
16	E-3711	ANCHOR PIN, XEM BRAKE
17	E-1565	WASHER - 2-3/8" OD X 1-5/8" ID X 1/16"
18	E-1567	BUSH, S-CAM SPIDER
19	E-1569	CAMSHAFT LOCK RING
20	E-4594	BUSH AND BRACKET KIT
21	E-1577A	INNER CAM BUSH, LATE TYPE
22	E-1574SBK	SLACK ADJUSTER 1 5/8" - 37 SPLINE (3 HOLES)
23	E-580	WASHER - 2.25" OD X 1.53" ID X0.06"
24	1229Z1118	CIRCLIP
25	E-3861	'S' CAM, LH - 23-7/8" / 606MM
25	E-3862	'S' CAM, RH - 23-7/8" / 606MM
26	1229X1116	CIRCLIP
27	E-1113	WASHER
28	E-1893	ANCHOR PIN BUSH - STAINLESS STEEL
29	E-1112A	ANCHOR PIN - STANDARD
30	-	ANCHOR PIN BOLT ON TYPE LONG (NOT SOLD SEPARATELY - PART OF KITS E-8465AU & E-8466AU)

More Parts Next Page 



# HOLLAND T SERIES TRAILER AXLE

TAPERED BEARINGS  
16-1/2" x 7" BRAKES

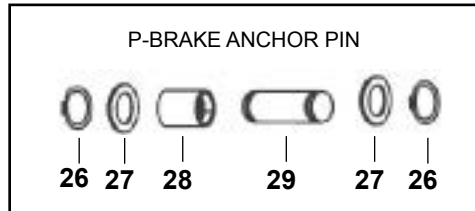
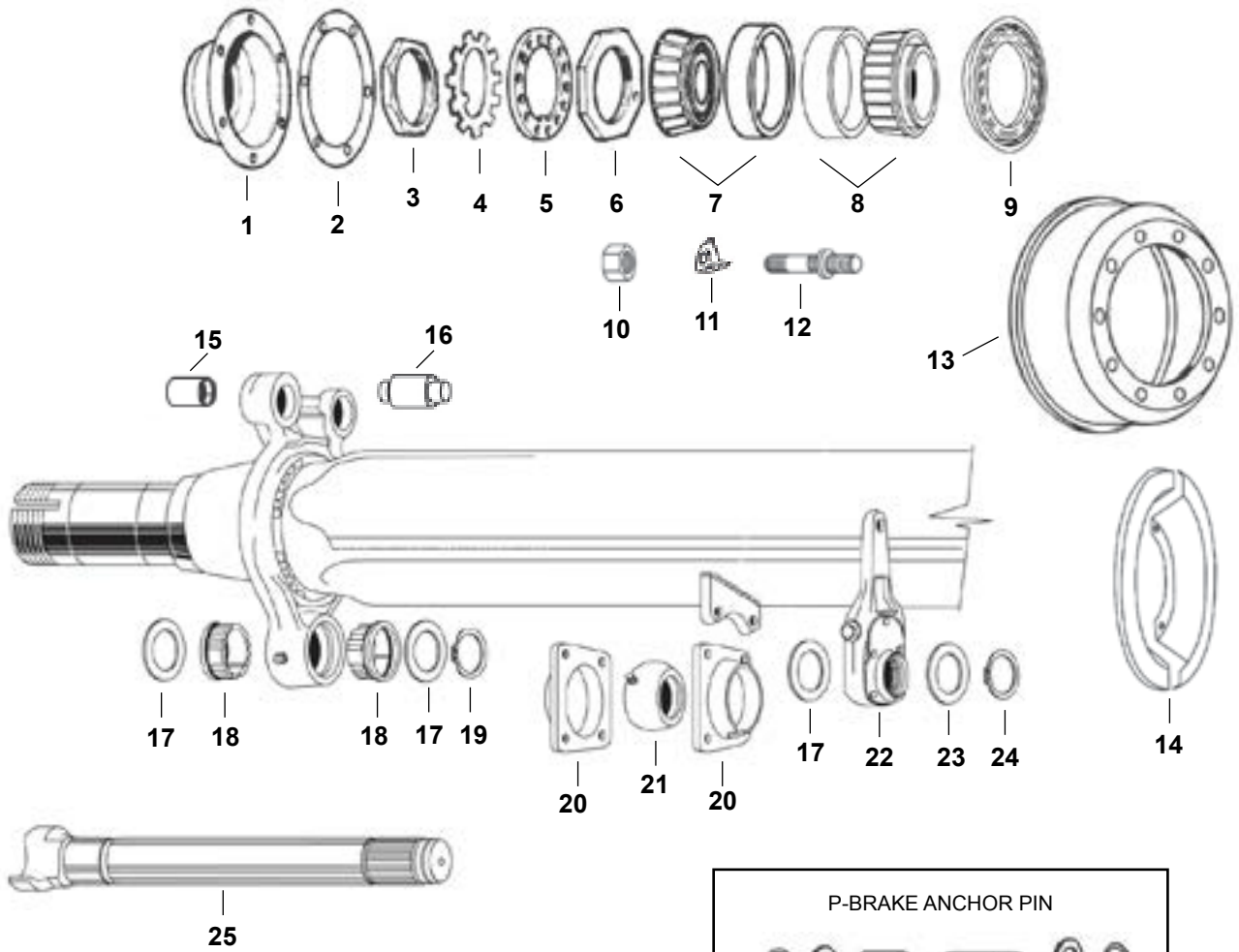

## XEM "Q" TYPE BRAKE

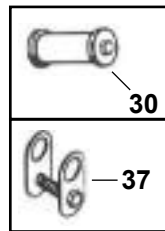
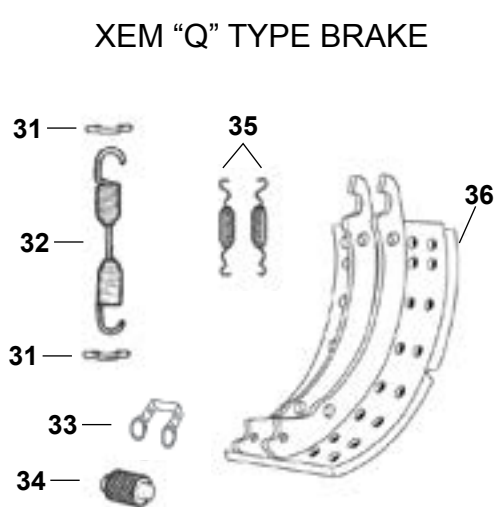

## "P" TYPE BRAKE

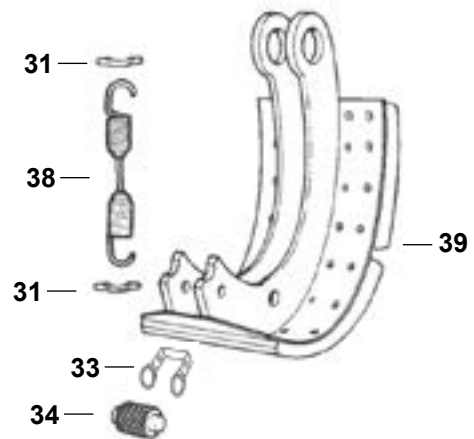

# HOLLAND T SERIES TRAILER AXLE

TAPERED BEARINGS  
16-1/2" x 7" BRAKES

ITEM NUMBER	PART NUMBER	DESCRIPTION
31	E-747	SPRING RETAINER
32	2258W803	RETURN SPRING - 1 PER XEM BRAKE
33	E-3227	CAM ROLLER RETAINER
34	2297T7222	ROLLER - SMOOTH
34	E-2177	ROLLER - KNURLED
34	E-2215	ROLLER - KNURLED 1/8" OVERSIZE
34	E-781	ROLLER - SMOOTH 1/8" OVERSIZE
34	E-586	ROLLER - SMOOTH 1/4" OVERSIZE
35	E-2767	RETAINING SPRING - 2 PER XEM BRAKE
36	-	UNLINED BRAKE SHOE - LINING REF. 4515E - (NOT SOLD SEPARATELY - PART OF KIT KSMA2124515F3)
36	-	LINED BRAKE SHOE (NOT SOLD SEPARATELY - PART OF KIT EKSMG2A4515F3)
37	-	BOLT ON TYPE CAM ROLLER RETAINER (NOT SOLD SEPARATELY - PART OF KITS E-8465AU & E-8466AU)
38	E-1880B	RETURN SPRING - 1 PER P-BRAKE
39	E-2685	UNLINED BRAKE SHOE (LINING REF. 4515E)
39	-	LINED BRAKE SHOE (NOT SOLD SEPARATELY - PART OF KIT EKSMG2A4515F)

KIT	E-1816SHD	BRAKE KIT 'P' BRAKE WITH CIRCLIP ANCHOR PINS. ALL BRAKE HARDWARE KITS INCLUDE ENOUGH COMPONENTS TO SERVICE 1 WHEEL.
KIT	E-8466AU	BRAKE KIT 'P' BRAKE WITH LONG BOLT-ON ANCHOR PINS. ALL BRAKE HARDWARE KITS INCLUDE ENOUGH COMPONENTS TO SERVICE 1 WHEEL.
KIT	E-8465AU	BRAKE KIT 'P' BRAKE - SAME AS E-8466AU BUT SMOOTH ROLLERS. ALL BRAKE HARDWARE KITS INCLUDE ENOUGH COMPONENTS TO SERVICE 1 WHEEL.
KIT	R507008	BRAKE KIT XEM BRAKE. ALL BRAKE HARDWARE KITS INCLUDE ENOUGH COMPONENTS TO SERVICE 1 WHEEL.
KIT	E-2090	CAMSHAFT BUSH KIT. CAMSHAFT REPAIR KIT SERVICES 1 CAMSHAFT. CAMSHAFT BUSH KIT SERVICES 1 AXLE.
KIT	KSMA2124515F3**	4515 XEM Q TYPE - MAJOR BRAKE SHOE KIT - CONSISTS OF 2 LINED SHOES & HARDWARE KIT - SERVICES 1 WHEEL.
KIT	EKSMG2A4515F3*	4515 XEM Q TYPE - MAJOR BRAKE SHOE KIT - CONSISTS OF 2 LINED SHOES & HARDWARE KIT - SERVICES 1 WHEEL.
KIT	EKSMG2A4515F*	4515 FRUEHAUF P TYPE - MAJOR BRAKE SHOE KIT - CONSISTS OF 2 LINED SHOES & HARDWARE KIT - SERVICES 1 WHEEL.
KIT	KSMA2124515F**	4515 FRUEHAUF P TYPE - MAJOR BRAKE SHOE KIT - CONSISTS OF 2 LINED SHOES & HARDWARE KIT - SERVICES 1 WHEEL.

\* Please contact Customer Service for details on other grades of friction material available.

\*\* Restricted sale.



# MERITOR ROCKWELL

ARN/ATN (10 SPLINE)  
4000/6000 (28 SPLINE)

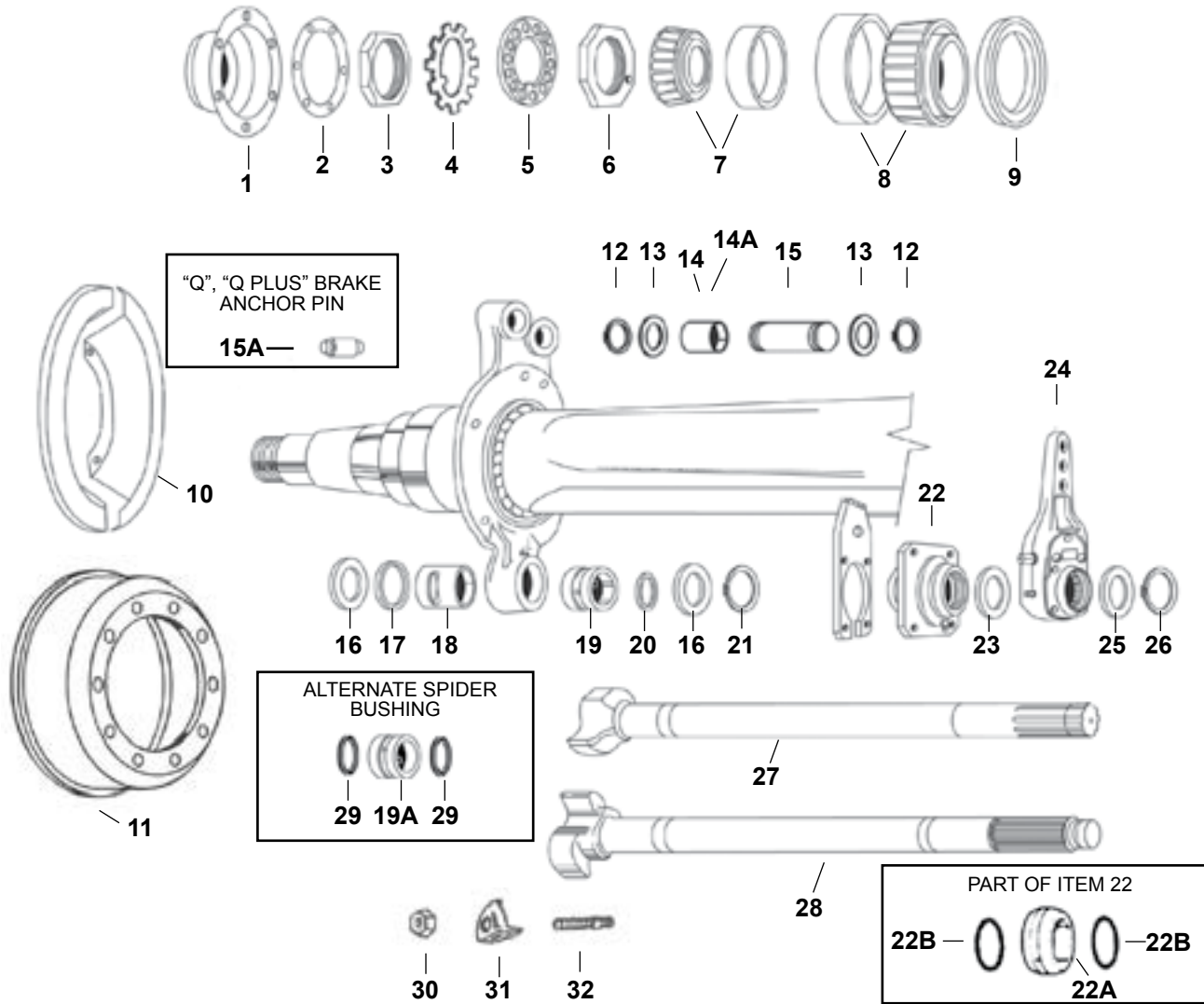

## "P" BRAKE

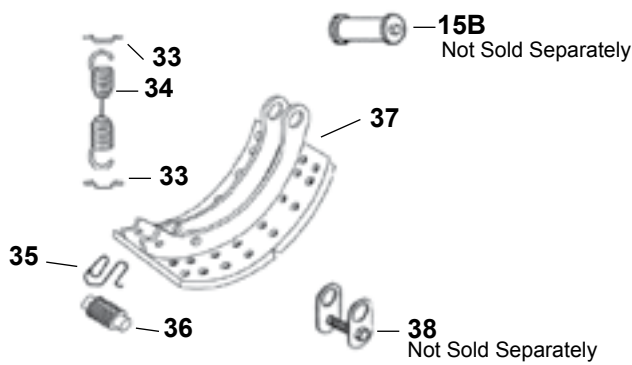

## "Q" BRAKE

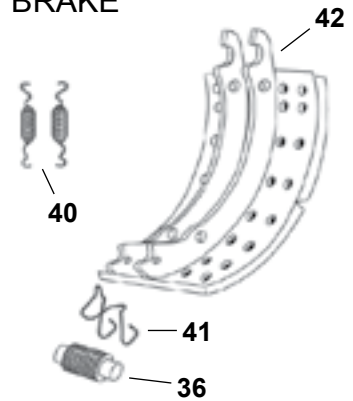



# MERITOR ROCKWELL

ARN/ATN (10 SPLINE)  
4000/6000 (28 SPLINE)

ITEM NUMBER	PART NUMBER	DESCRIPTION
1	E-975	HUB CAP GREASE
2	E-03009	GASKET - HUB CAP
3	E-572	OUTER AXLE SPINDLE NUT
4	E-2237	LOCK TAB WASHER
5	E-573	LOCK WASHER
6	E-540	INNER AXLE SPINDLE NUT
7	MERSET414	INNER BEARING SET (HM/218248/HM218210)
8	MERSET413	OUTER BEARING SET (HM212049/HM212011)
9	MER0143	AXLE SEAL OIL
10	E-886	DUST COVER - STEEL
10	E-3775	DUST COVER - PLASTIC
11	03-122222-002	BRAKE DRUM - 9 7/16" SPIGOT (GP/MALCO) 11" PCD 5 & 6 BOLT HOLES
11		BRAKE DRUM - 11-1/4" SPIGOT
12	1229X1116	CIRCLIP
13	E-1113	WASHER - 1.88" OD X 1.27" ID X 0.06" THICKNESS
14	E-1893	ANCHOR PIN BUSH - STAINLESS STEEL
14A	1225B496	ANCHOR PIN BUSH - BRONZE LINED
15	1259M1131	ANCHOR PIN - STANDARD (CIRCLIP TYPE)
15A	1259N274	Q' BRAKE ANCHOR PIN
15B	-	ANCHOR PIN - BOLT ON TYPE LONG (NOT SOLD SEPARATELY - PART OF KITS E-8465AU & E-8466AU)
16	1229X3118	WASHER - 2.25" OD X 1.63" ID X 0.06" THICKNESS
17	E-2405	SEAL
18	E-2407	OUTER CAM BUSH
19	E-2408	OUTER CAM BUSH
19A	E-2690A	CAM BUSH - CAN REPLACE ITEMS 18 & 19
20	E-2406	SEAL
21	E-1569	CAMSHAFT LOCK RING
22	E-1318A	BRACKET & BUSH ASSEMBLY
22A	E-2361	BUSH
22B	E-1314	O RING
23	E-580	WASHER
24	E-612S-BK	SLACK ADJUSTER - 3 HOLE X 10 SPLINE
24A	E-2458S-BK	SLACK ADJUSTER - 3 HOLE X 28 SPLINE

More Parts Next Page 



# MERITOR ROCKWELL

ARN/ATN (10 SPLINE)  
4000/6000 (28 SPLINE)

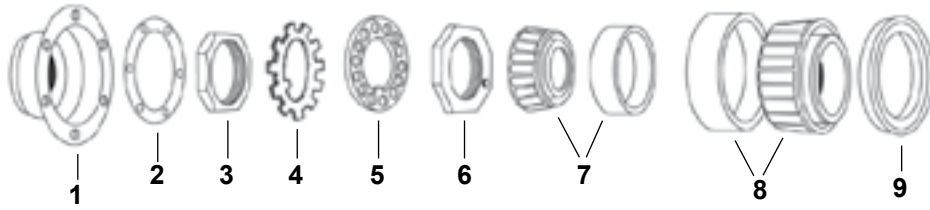

"Q", "Q PLUS" BRAKE  
ANCHOR PIN  
15A—

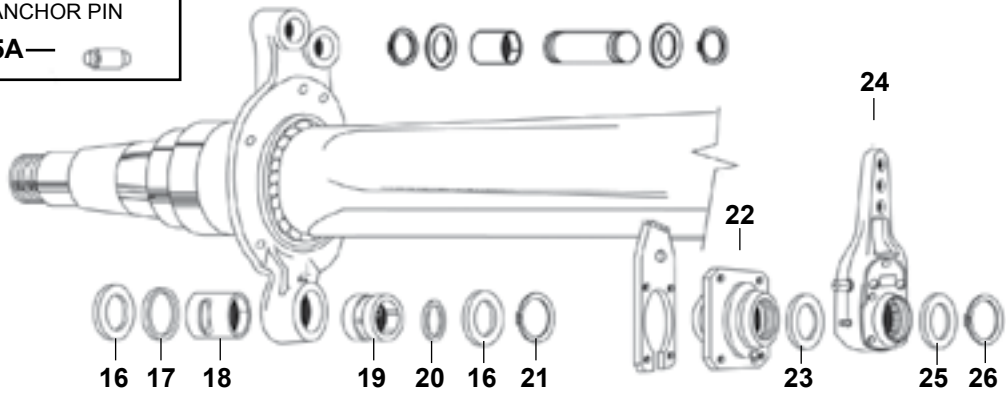
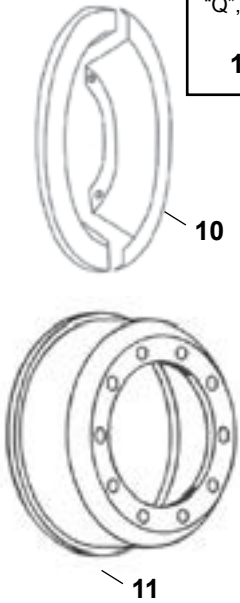
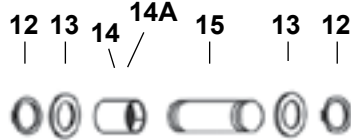

ALTERNATE SPIDER  
BUSHING  
29 19A 29

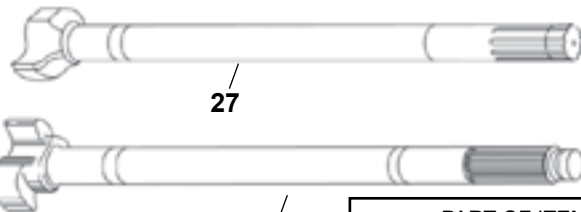

PART OF ITEM 22  
22B— 22A



## "P" BRAKE

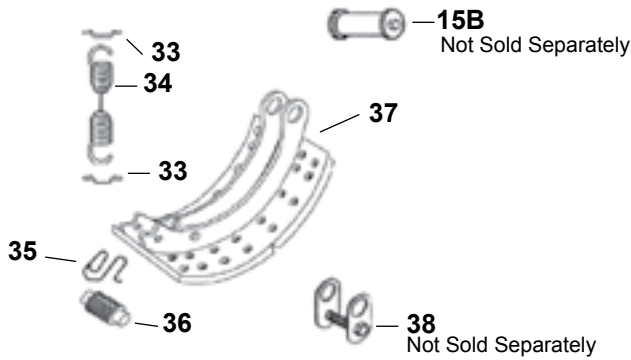

## "Q" BRAKE

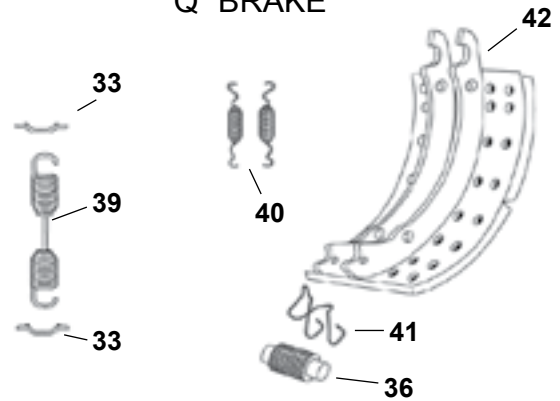

# MERITOR ROCKWELL

ARN/ATN (10 SPLINE)  
4000/6000 (28 SPLINE)

ITEM NUMBER	PART NUMBER	DESCRIPTION
25	E-1113	WASHER - 1.88" OD X 1.27" ID X 0.06" THICKNESS
26	1229X1116	CAMSHAFT LOCK RING
27	E-2449A	S CAM LH 10 SPLINE
27	E-2450A	S CAM RH 10 SPLINE
28	E-2443B	S CAM LH 28 SPLINE
28	E-2444B	S CAM RH 28 SPLINE
29	E-3991	SEAL
30	E-7775	WHEEL NUT
31	E-5571A	WHEEL CLAMP (FOR 5/6 SPOKE HUBS ONLY)
32	R004956A	WHEEL STUD
33	E-747	SPRING RETAINER
34	E-1880B	RETURN SPRING - 1 PER WHEEL P BRAKE
35	E-539	ROLLER RETAINER
36	2297T7222	ROLLER, SMOOTH
36	E-2177	ROLLER, KNURLED
36	E-2215	ROLLER, KNURLED 1/8" OVERSIZE
36	E-781	ROLLER, SMOOTH 1/8" OVERSIZE
36	E-586	ROLLER, SMOOTH 1/4" OVERSIZE
37	-	LINED BRAKE SHOE (NOT SOLD SEPARATELY - PART OF KIT PKSMA2124515P)
37	-	LINED BRAKE SHOE (NOT SOLD SEPARATELY - PART OF KIT EKSMG2A4515PHD)
37	-	LINED BRAKE SHOE WITH WELDED WASHERS (NOT SOLD SEPARATELY - PART OF KIT PKSMA2124515PSS)
37	-	LINED BRAKE SHOE WITH WELDED WASHERS (NOT SOLD SEPARATELY - PART OF KIT EKSMG2A4515PSS)
38	-	BOLT-ON ROLLER RETAINER KIT (NOT SOLD SEPARATELY - PART OF KITS E-8465AU & E-8466AU)
39	2258W803	RETURN SPRING - 1 PER WHEEL 'Q' BRAKE
40	E-2767	RETAINING SPRING - 2 PER WHEEL 'Q' BRAKE
41	3105B210	ROLLER RETAINER
42	-	LINED BRAKE SHOE (NOT SOLD SEPARATELY - PART OF KIT KSMA2124515Q)
42	-	LINED BRAKE SHOE (NOT SOLD SEPARATELY - PART OF KIT EKSMG2A4515Q)

More Parts Next Page 



# MERITOR ROCKWELL

ARN/ATN (10 SPLINE)  
4000/6000 (28 SPLINE)

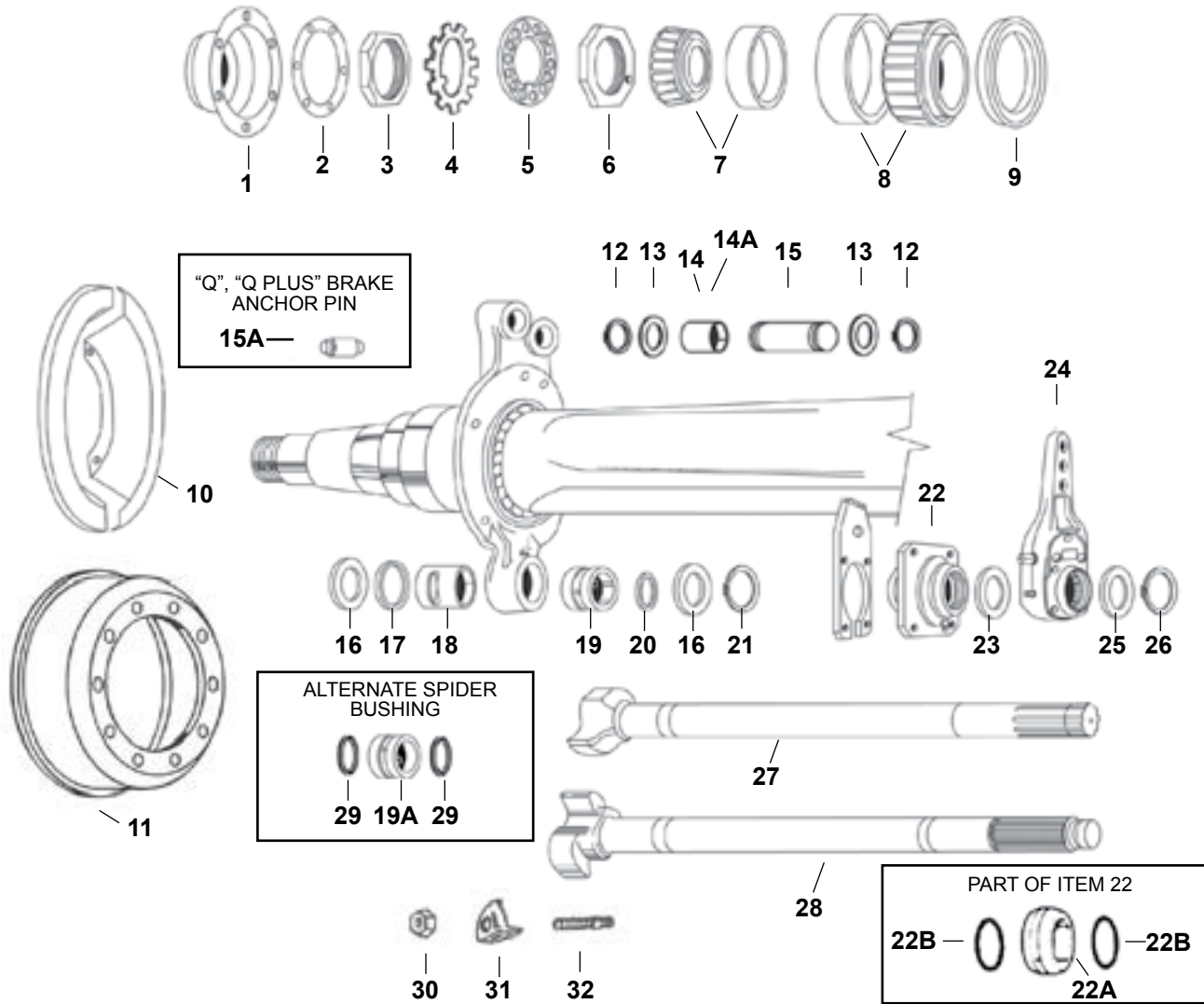

## “P” BRAKE

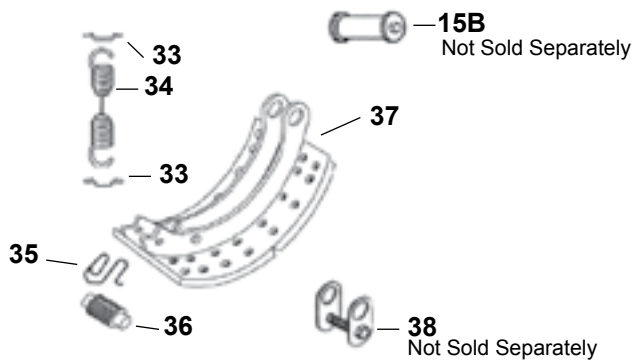

## “Q” BRAKE

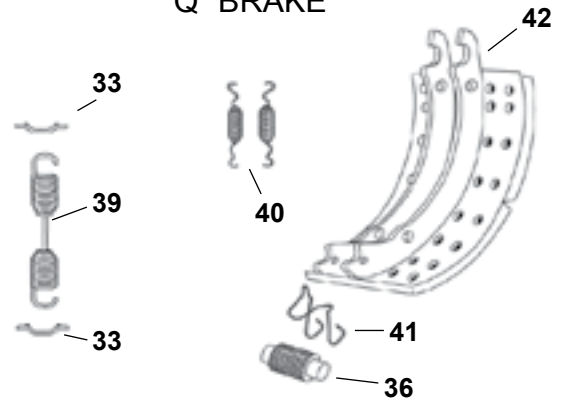

# MERITOR ROCKWELL

ARN/ATN (10 SPLINE)  
4000/6000 (28 SPLINE)

ITEM NUMBER	PART NUMBER	DESCRIPTION
KIT	E-1816SHD	BRAKE HARDWARE KIT 'P' BRAKE WITH CIRCLIP ANCHOR PINS.
KIT	E-8466AU	BRAKE HARDWARE KIT 'P' BRAKE WITH LONG BOLT-ON ANCHOR PINS.
KIT	E-8465AU	BRAKE HARDWARE KIT 'P' BRAKE - SAME AS E-8466AU BUT SMOOTH ROLLERS
KIT	KIT8000HD**	BRAKE HARDWARE KIT 'Q' BRAKE
KIT	E-2769HD	BRAKE HARDWARE KIT 'Q' BRAKE
KIT	KIT8048**	CAMSHAFT REPAIR KIT. INCLUDES ITEM 19A AND OTHERS - SERVICES 2 BRAKES
KIT	E-3520A	CAMSHAFT REPAIR KIT. INCLUDES ITEM 19A AND OTHERS - SERVICES 2 BRAKES
KIT	KIT970	CAMSHAFT REPAIR KIT. INCLUDES ITEMS 18 & 19 AND OTHERS - SERVICES 2 BRAKES
KIT	PKSMA2124515P**	4515P - MAJOR BRAKE SHOE KIT - CONSISTS OF 2 LINED SHOES & HARDWARE KIT - SERVICES 1 WHEEL.
KIT	EKSMG2A4515PHD*	4515P - MAJOR BRAKE SHOE KIT - CONSISTS OF 2 LINED SHOES & HARDWARE KIT - SERVICES 1 WHEEL.
KIT	PKSMA2124515PSS**	4515P - SHOE WITH WELDED WASHERS AND SMOOTH ROLLERS - MAJOR BRAKE SHOE KIT - CONSISTS OF 2 LINED SHOES & HARDWARE KIT - SERVICES 1 WHEEL.
KIT	EKSMG2A4515PSS*	4515P - SHOE WITH WELDED WASHERS AND SMOOTH ROLLERS - MAJOR BRAKE SHOE KIT - CONSISTS OF 2 LINED SHOES & HARDWARE KIT - SERVICES 1 WHEEL.
KIT	EKSMG2A4515PSSK*	4515P - SHOE WITH WELDED WASHERS AND KNURLED ROLLERS - MAJOR BRAKE SHOE KIT - CONSISTS OF 2 LINED SHOES & HARDWARE KIT - SERVICES 1 WHEEL.
KIT	KSMA2124515Q**	4515Q - MAJOR BRAKE SHOE KIT - CONSISTS OF 2 LINED SHOES & HARDWARE KIT - SERVICES 1 WHEEL.
KIT	EKSMG2A4515Q*	4515Q - MAJOR BRAKE SHOE KIT - CONSISTS OF 2 LINED SHOES & HARDWARE KIT - SERVICES 1 WHEEL.

\* Please contact Customer Service for details on other grades of friction material available.

\*\* Restricted sale.

# MERITOR ROCKWELL

RN / TN AXLE  
16-1/2" x 7" BRAKES

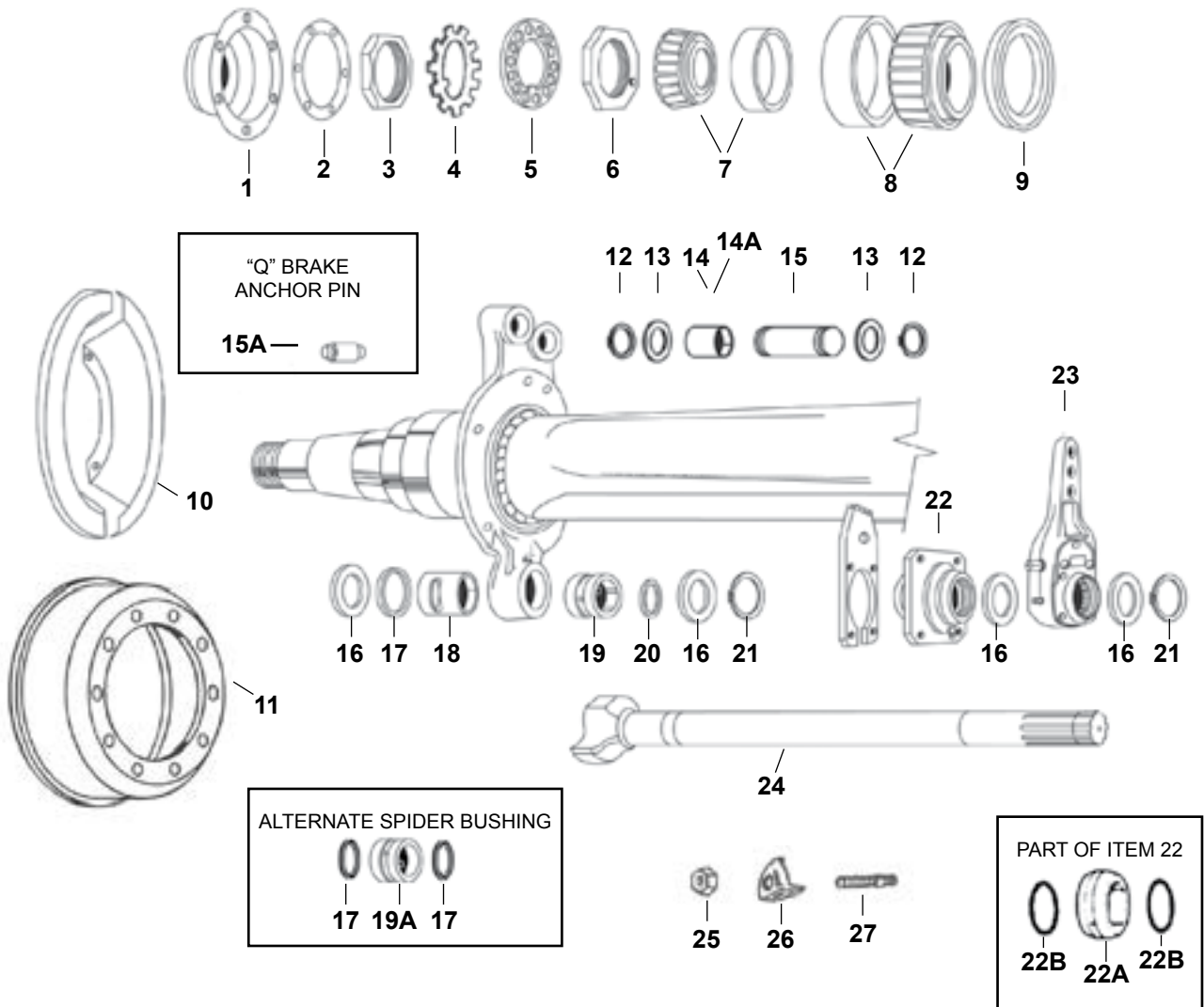

## "P" BRAKE

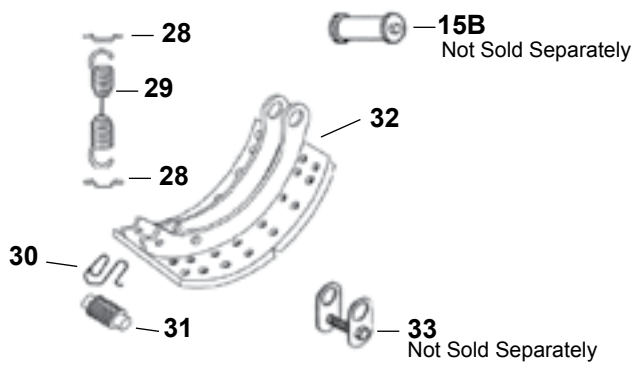

## "Q" BRAKE

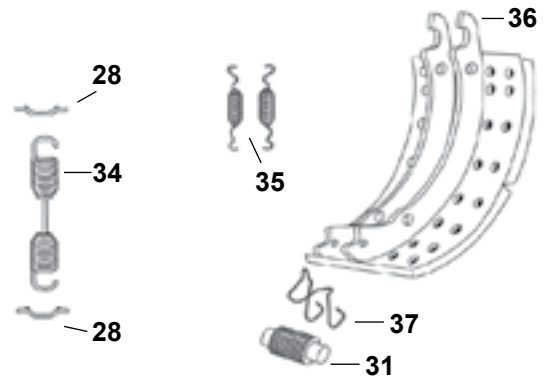

# MERITOR ROCKWELL

RN / TN AXLE  
16-1/2" x 7" BRAKES

ITEM NUMBER	PART NUMBER	DESCRIPTION
1	E-975	HUB CAP GREASE
2	E-03009	GASKET - HUB CAP
3	E-572	OUTER AXLE SPINDLE NUT
3A	E-1251	OUTER AXLE SPINDLE NUT - RN AXLE
4	E-2237	LOCK TAB WASHER
5	E-573	LOCK WASHER
5A	E-1252	LOCK WASHER - RN AXLE
6	E-540	INNER AXLE SPINDLE NUT
6A	E-2128	INNER AXLE SPINDEL NUT - RN AXLE
7	MERSET414	INNER BEARING SET (HM/218248/HM218210)
8	MERSET413	OUTER BEARING SET (HM212049/HM212011)
9	MER0143	AXLE SEAL OIL
10	E-886	DUST COVER
11	03-122222-002	BRAKE DRUM 11" PCD 9.44" SPIGOT 5 & 6 BOLT HOLES
11	-	BRAKE DRUM - 11-1/4" SPIGOT
12	1229X1116	CAMSHAFT LOCK RING
13	E-1113	WASHER - 1.88" OD X 1.27" ID X 0.06" THICKNESS
14	E-1893	ANCHOR PIN BUSH - STAINLESS STEEL
14A	1225B496	ANCHOR PIN BUSH - BRONZE LINED
15	1259M1131	ANCHOR PIN - STANDARD (CIRCLIP TYPE)
15A	1259N274	Q' BRAKE ANCHOR PIN
15B	-	ANCHOR PIN - BOLT ON TYPE LONG (NOT SOLD SEPARATELY - PART OF KITS E-8465AU & E-8466AU)
16	E-564	WASHER
17	E-1416	SEAL
18	E-2380	OUTER CAM BUSH
19	E1271	OUTER CAM BUSH
19A	E-759	CAM BUSH - CAN REPLACE ITEMS 18 & 19
20	E-1272	SEAL
21	1229Z1118	CIRCLIP
22	E-1318A	BRACKET & BUSH ASSEMBLY
22A	E-2361	BUSH
22B	E-1314	O RING
23	E-612S-BK	SLACK AJUSTER - 3 HOLE, 10 SPLINE
24	E-1425A	S CAM LH 10 SPLINE
24	E-1424A	S CAM RH 10 SPLINE

More Parts Next Page 



# MERITOR ROCKWELL

RN / TN AXLE  
16-1/2" x 7" BRAKES

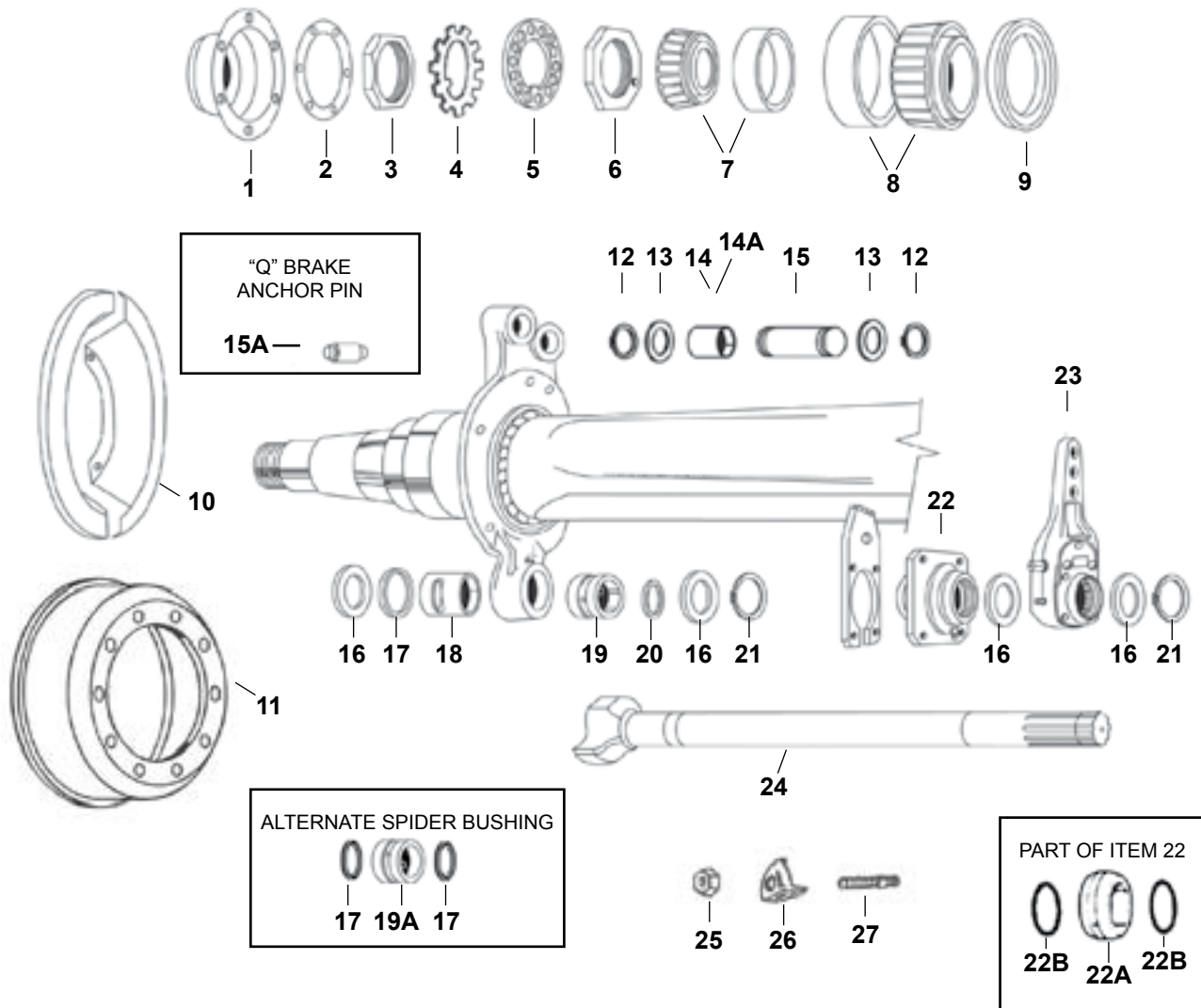

## "P" BRAKE

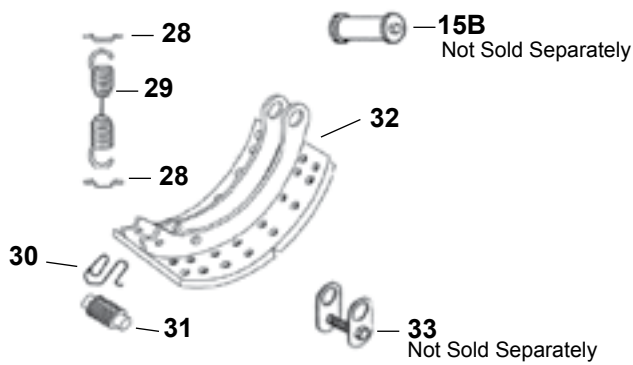

## "Q" BRAKE

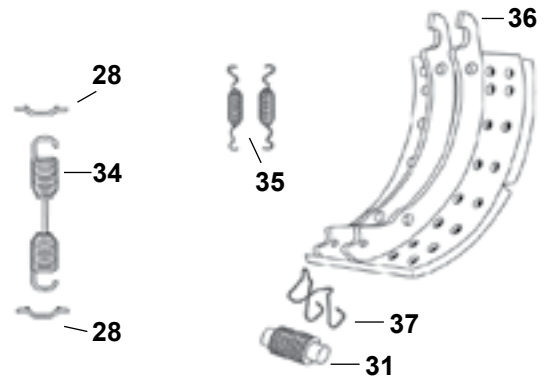



# MERITOR ROCKWELL

RN / TN AXLE  
16-1/2" x 7" BRAKES

ITEM NUMBER	PART NUMBER	DESCRIPTION
25	E-7775	WHEEL NUT
26	E-5571A	WHEEL CLAMP (FOR 5/6 SPOKE HUBS ONLY)
27	R004956A	WHEEL STUD
28	E-747	SPRING RETAINER
29	E-1880B	RETURN SPRING - 1 PER WHEEL P BRAKE
30	E-539	ROLLER RETAINER
31	2297T7222	ROLLER, SMOOTH
31	E-2177	ROLLER, KNURLED
31	E-2215	ROLLER, KNURLED 1/8" OVERSIZE
31	E-781	ROLLER, SMOOTH 1/8" OVERSIZE
31	E-586	ROLLER, SMOOTH 1/4" OVERSIZE
32	-	LINED BRAKE SHOE (NOT SOLD SEPARATELY - PART OF KIT PKSMA2124515P)
32	-	LINED BRAKE SHOE (NOT SOLD SEPARATELY - PART OF KIT EKSMG2A4515PHD)
32	-	LINED BRAKE SHOE WITH WELDED WASHERS (NOT SOLD SEPARATELY - PART OF KIT PKSMA2124515PSS)
32	-	LINED BRAKE SHOE WITH WELDED WASHERS (NOT SOLD SEPARATELY - PART OF KIT EKSMG2A4515PSS)
33	-	BOLT-ON ROLLER RETAINER KIT (NOT SOLD SEPARATELY - PART OF KITS E-8465AU & E-8466AU)
34	2258W803	RETURN SPRING - 1 PER WHEEL 'Q' BRAKE
35	E-2767	RETAINING SPRING - 2 PER WHEEL 'Q' BRAKE
36	-	LINED BRAKE SHOE (NOT SOLD SEPARATELY - PART OF KIT KSMA2124515Q)
36	-	LINED BRAKE SHOE (NOT SOLD SEPARATELY - PART OF KIT EKSMG2A4515Q)
37	3105B210	ROLLER RETAINER

More Parts Next Page 



# MERITOR ROCKWELL

RN / TN AXLE  
16-1/2" x 7" BRAKES

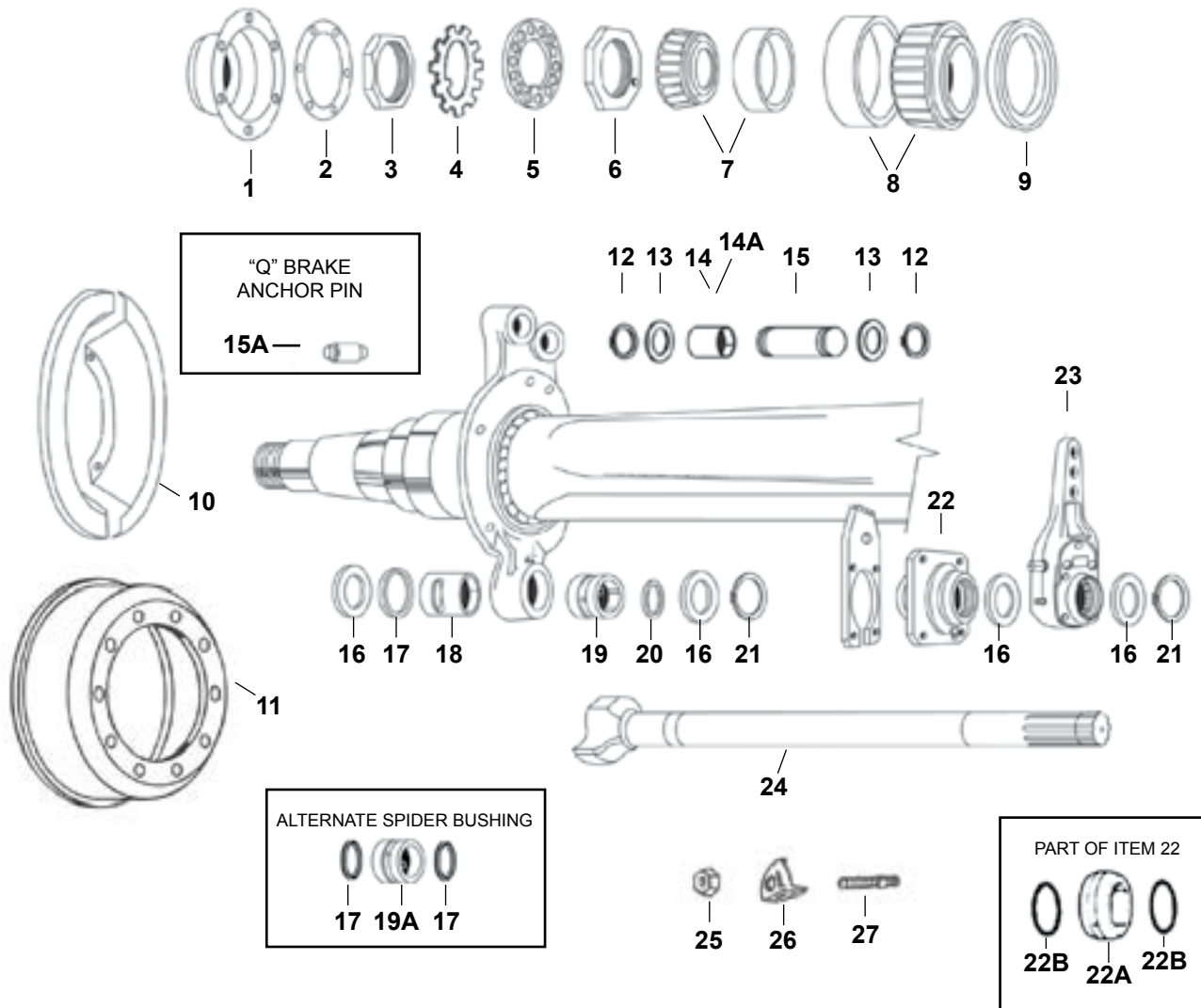

## "P" BRAKE

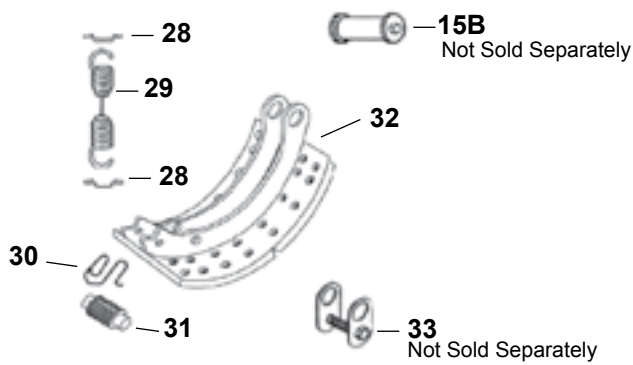

## "Q" BRAKE

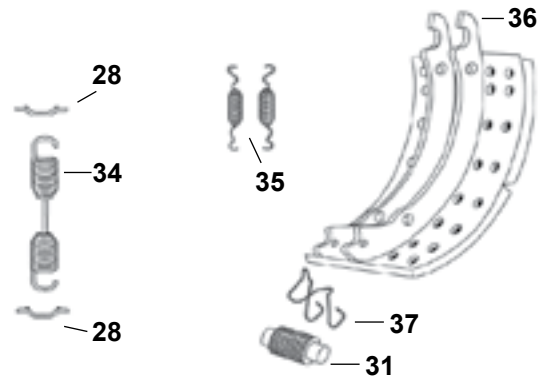

# MERITOR ROCKWELL

RN / TN AXLE  
16-1/2" x 7" BRAKES

ITEM NUMBER	PART NUMBER	DESCRIPTION
KIT	E-1816SHD	BRAKE HARDWARE KIT 'P' BRAKE WITH CIRCLIP ANCHOR PINS.
KIT	E-8466AU	BRAKE HARDWARE KIT 'P' BRAKE WITH LONG BOLT-ON ANCHOR PINS WITH KNURLED ROLLERS
KIT	E-8465AU	BRAKE HARDWARE KIT 'P' BRAKE - SAME AS E-8466AU BUT SMOOTH ROLLERS
KIT	KIT8000HD**	BRAKE HARDWARE KIT 'Q' BRAKE WITH STD ROLLER RETAINER
KIT	E-2769HD	BRAKE HARDWARE KIT 'Q' BRAKE WITH STD ROLLER RETAINER
KIT	E-2088AHD	CAMSHAFT REPAIR KIT. RN AXLE
KIT	PKSMA2124515P**	4515P - MAJOR BRAKE SHOE KIT - CONSISTS OF 2 LINED SHOES & HARDWARE KIT - SERVICES 1 WHEEL.
KIT	EKSMG2A4515PHD*	4515P - MAJOR BRAKE SHOE KIT - CONSISTS OF 2 LINED SHOES & HARDWARE KIT - SERVICES 1 WHEEL.
KIT	PKSMA2124515PSS**	4515P - SHOE WITH WELDED WASHERS AND SMOOTH ROLLERS - MAJOR BRAKE SHOE KIT - CONSISTS OF 2 LINED SHOES & HARDWARE KIT - SERVICES 1 WHEEL.
KIT	EKSMG2A4515PSS*	4515P - SHOE WITH WELDED WASHERS AND SMOOTH ROLLERS - MAJOR BRAKE SHOE KIT - CONSISTS OF 2 LINED SHOES & HARDWARE KIT - SERVICES 1 WHEEL.
KIT	EKSMG2A4515PSSK*	4515P - SHOE WITH WELDED WASHERS AND KNURLED ROLLERS - MAJOR BRAKE SHOE KIT - CONSISTS OF 2 LINED SHOES & HARDWARE KIT - SERVICES 1 WHEEL.
KIT	KSMA2124515Q**	4515Q - MAJOR BRAKE SHOE KIT - CONSISTS OF 2 LINED SHOES & HARDWARE KIT - SERVICES 1 WHEEL.
KIT	EKSMG2A4515Q*	4515Q - MAJOR BRAKE SHOE KIT - CONSISTS OF 2 LINED SHOES & HARDWARE KIT - SERVICES 1 WHEEL.



## Found an error?

If you detect any errors in this catalogue, please let us know. We want to ensure the information we publish is as accurate as possible. We appreciate your help in making this happen.

Please forward your enquiries to:  
**Email:** [meritoraftermarketau@meritor.com](mailto:meritoraftermarketau@meritor.com)  
**Phone:** (03) 8353 6050

\* Please contact Customer Service for details on other grades of friction material available.

\*\* Restricted sale.



# MERITOR TN/TQ AXLE

FABRICATED BRAKE SPIDER  
16-1/2" x 7" BRAKES

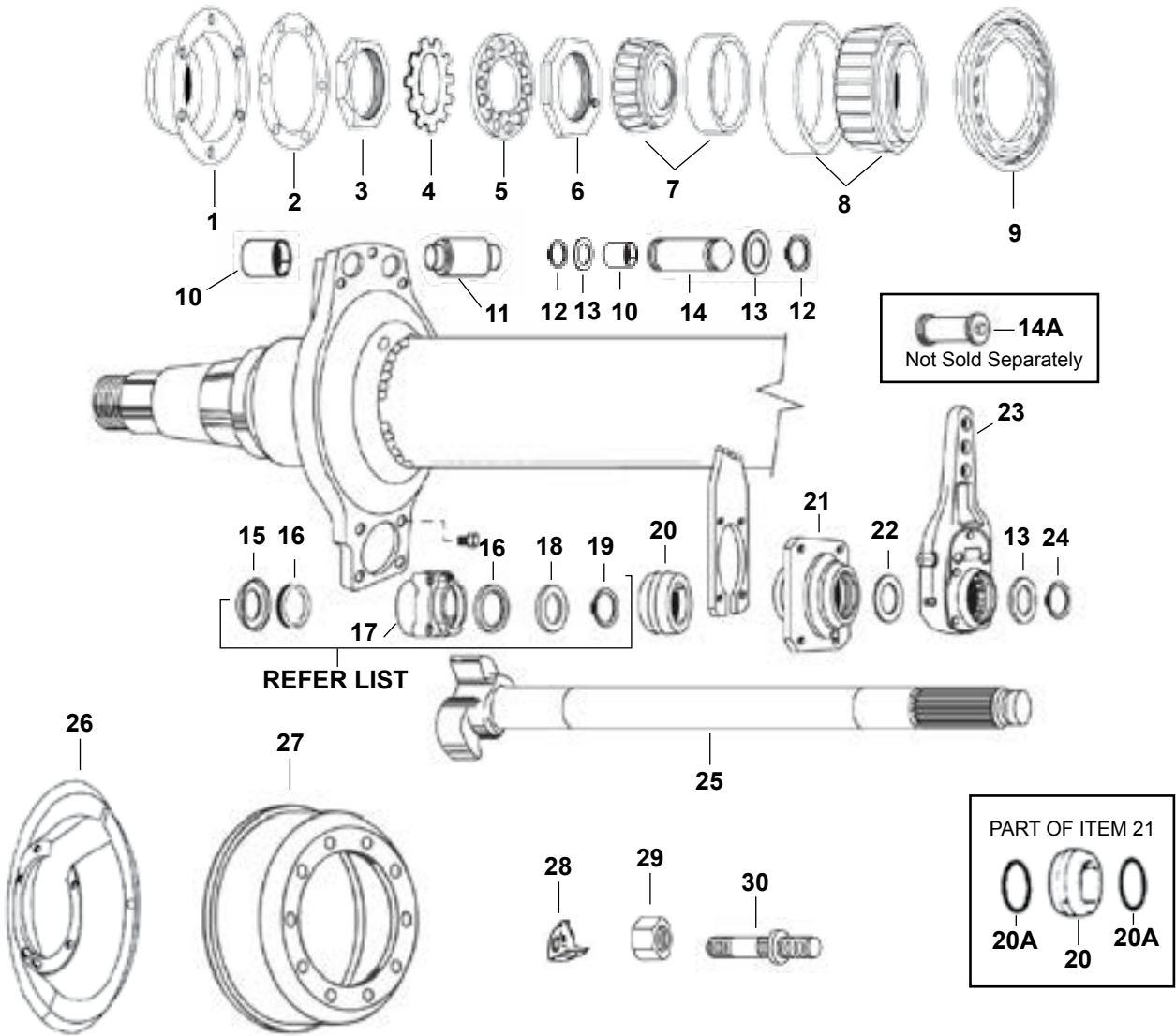

"Q" & "Q" PLUS TYPE BRAKE

H/D RETAINER OPTION

"P" TYPE BRAKE

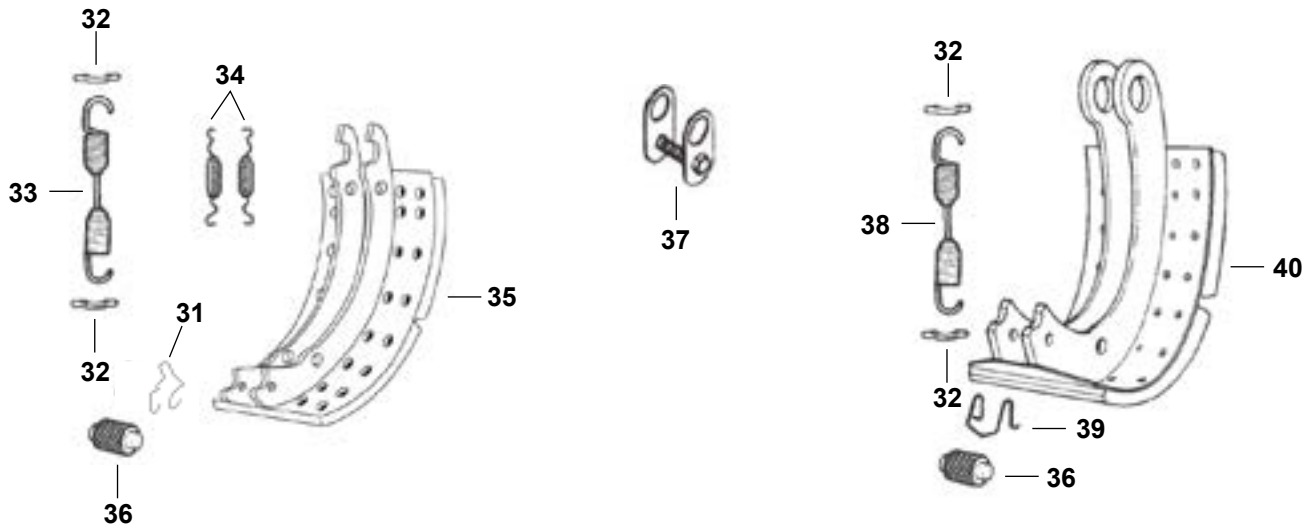

# MERITOR TN/TQ AXLE

FABRICATED BRAKE SPIDER  
16-1/2" x 7" BRAKES

ITEM NUMBER	PART NUMBER	DESCRIPTION
1	E-975	HUB CAP GREASE
2	E-03009	GASKET - HUB CAP
3	E-572	OUTER AXLE SPINDLE NUT
4	E-2237	LOCK TAB WASHER
5	E-573	LOCK WASHER
6	E-540	INNER AXLE SPINDLE NUT
7	MERSET414	INNER BEARING SET (HM/218248/HM218210)
8	MERSET413	OUTER BEARING SET (HM212049/HM212011)
9	MER0143	AXLE SEAL OIL
10	E-1893	ANCHOR PIN BUSH - STAINLESS STEEL
11	1259N274	Q' BRAKE ANCHOR PIN
12	1229X1116	CIRCLIP
13	E-1113	WASHER - 1.88" OD X 1.27" ID X 0.06" THICKNESS
14	E-1112A	ANCHOR PIN - STANDARD
14A	-	ANCHOR PIN (PART OF KITS E-8465AU & E-8466AU)
15	E-6077	CAM HEAD WASHER
16	E-2405	SEAL
17	A3105L1078	CAM BUSH
18	E-9072	WASHER
19	1229T4102	SNAP RING
20	E-2361	BUSH
20A	E-1314	O RING
21	E-1318A	BRACKET & BUSH ASSEMBLY
22	E-580	CAMSHAFT SPACER WASHER
23	E-2458S-BK	SLACK ADJUSTER - 3 HOLE, 28 SPLINE
24	1229X1116	CIRCLIP
25	E-5509	S' CAM RH 28 SLPINE X 20-7/16'/ 519MM
25	E-5508	S' CAM LH 28 SLPINE X 20-7/16'/ 519MM
25	E-5511	S' CAM RH 28 SLPINE X 20-7/16'/ 611MM
25	E-5510	S' CAM LH 28 SLPINE X 20-7/16'/ 611MM
26	E-886	DUST COVER
27	03-122222-002	BRAKE DRUM 11" PCD 9.44" SPIGOT 5 & 6 BOLT HOLES
28	E-5571A	WHEEL CLAMP (FOR 5/6 SPOKE HUBS ONLY)
29	E-7775	WHEEL NUT
30	R004956A	WHEEL STUD
31	3105B210	ROLLER RETAINER



# MERITOR TN/TQ AXLE

FABRICATED BRAKE SPIDER  
16-1/2" x 7" BRAKES

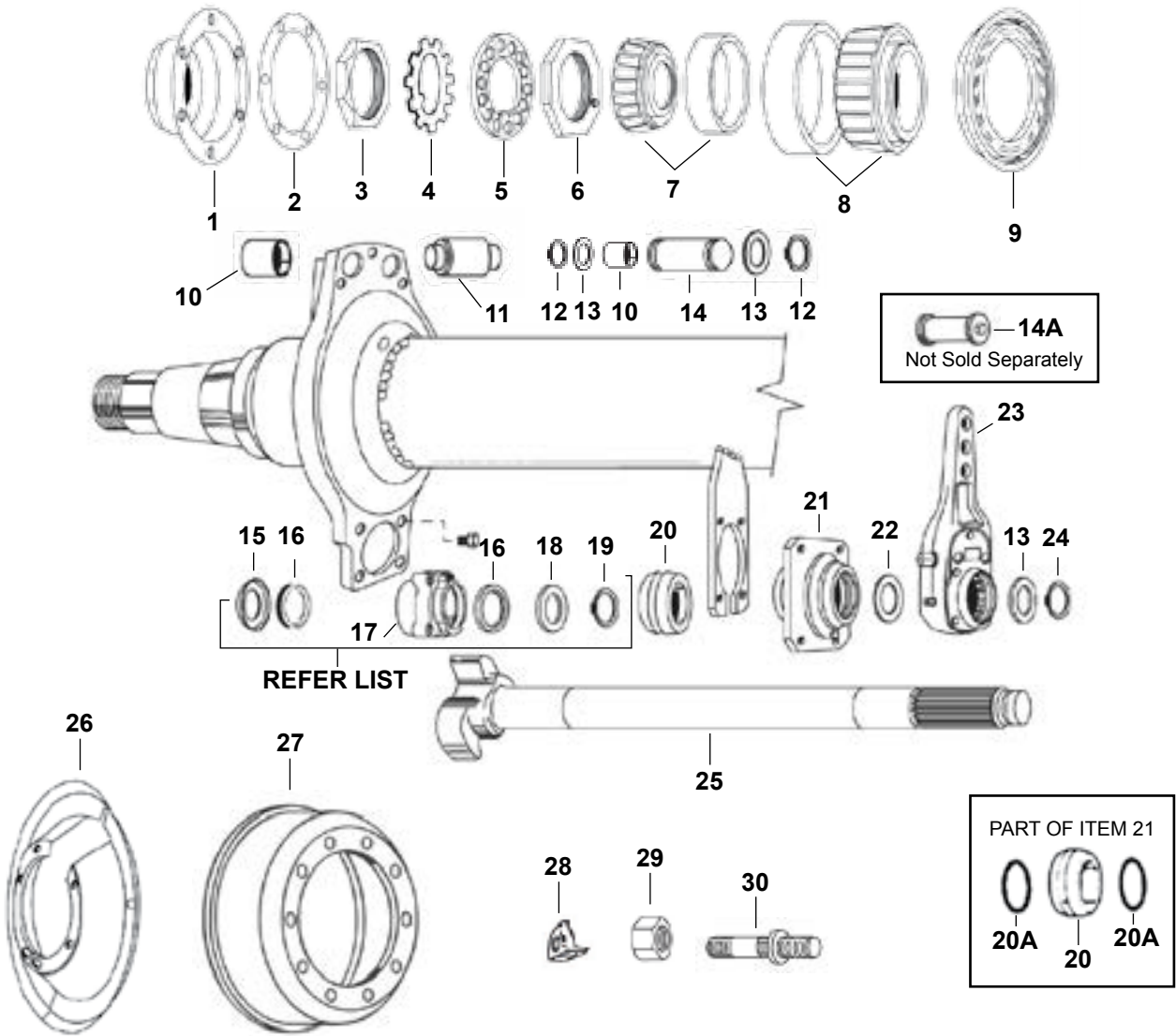

"Q" & "Q" PLUS TYPE BRAKE

H/D RETAINER OPTION

"P" TYPE BRAKE

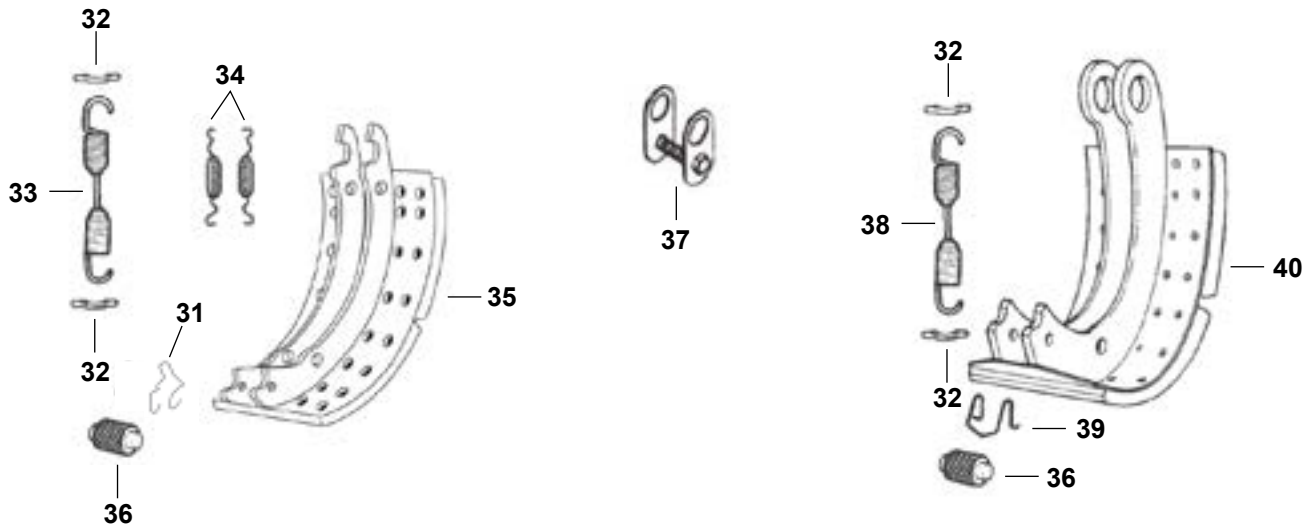

# MERITOR TN/TQ AXLE

FABRICATED BRAKE SPIDER  
16-1/2" x 7" BRAKES

ITEM NUMBER	PART NUMBER	DESCRIPTION
32	E-747	SPRING RETAINER
33	2258W803	RETURN SPRING - 1 PER WHEEL 'Q' BRAKE
34	E-2767	RETAINING SPRING - 2 PER WHEEL 'Q' BRAKE
35	-	LINED BRAKE SHOE (NOT SOLD SEPARATELY - PART OF KIT KSMA2124515Q)
35	-	LINED BRAKE SHOE (NOT SOLD SEPARATELY - PART OF KIT EKSMG2A4515Q)
35	-	LINED BRAKE SHOE (NOT SOLD SEPARATELY - PART OF KIT KSMA2124707QP)
35	-	LINED BRAKE SHOE (NOT SOLD SEPARATELY - PART OF KIT EKSMG2A4707QP)
36	2297T7222	ROLLER, SMOOTH
36	E-2177	ROLLER, KNURLED
36	E-2215	ROLLER - KNURLED 1/8" OVERSIZE
36	E-781	ROLLER - SMOOTH 1/8" OVERSIZE
36	E-586	ROLLER - SMOOTH 1/4" OVERSIZE
37	-	BOLT-ON ROLLER RETAINER KIT (NOT SOLD SEPARATELY - PART OF KITS E-8465AU & E-8466AU)
38	E-1880B	RETURN SPRING - 1 PER WHEEL P BRAKE
39	E-539	ROLLER RETAINER
40	-	LINED BRAKE SHOE (NOT SOLD SEPARATELY - PART OF KIT PKSMA2124515P)
40	-	LINED BRAKE SHOE (NOT SOLD SEPARATELY - PART OF KIT EKSMG2A4515PHD)
40	-	LINED BRAKE SHOE WITH WELDED WASHERS (NOT SOLD SEPARATELY - PART OF KIT PKSMA2124515PSS)
40	-	LINED BRAKE SHOE WITH WELDED WASHERS (NOT SOLD SEPARATELY - PART OF KIT EKSMG2A4515PSS)

More Parts Next Page 



# MERITOR TN/TQ AXLE

FABRICATED BRAKE SPIDER  
16-1/2" x 7" BRAKES

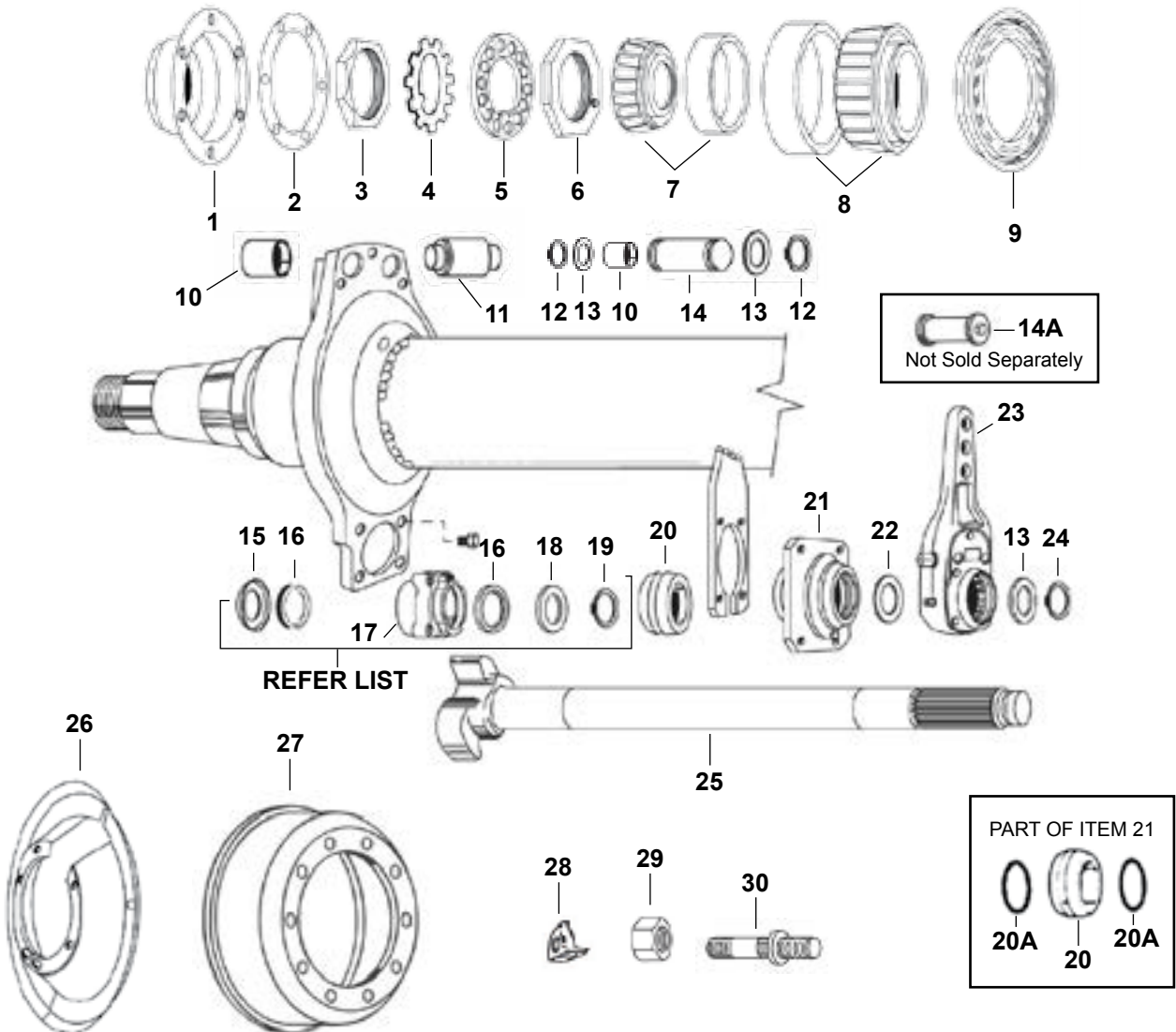

“Q” & “Q” PLUS TYPE BRAKE

H/D RETAINER OPTION

“P” TYPE BRAKE

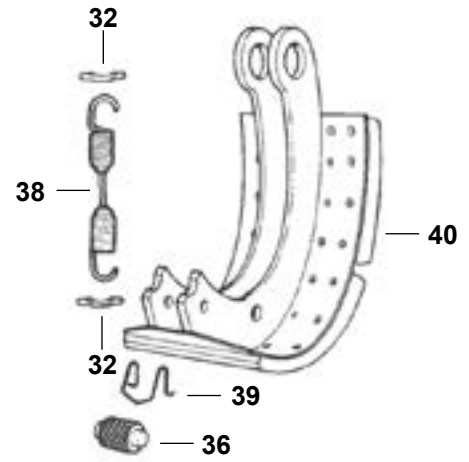
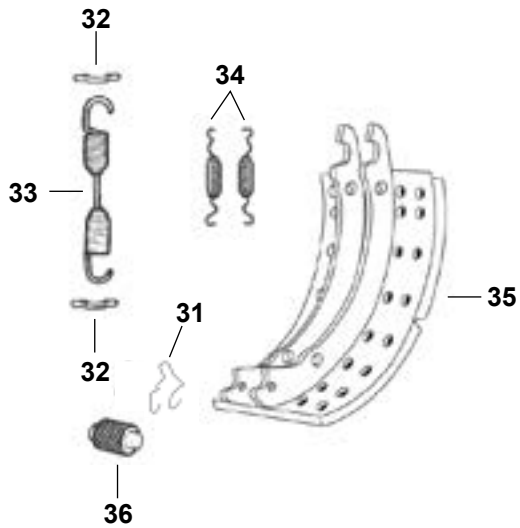



# MERITOR TN/TQ AXLE

## FABRICATED BRAKE SPIDER

### 16-1/2" x 7" BRAKES

ITEM NUMBER	PART NUMBER	DESCRIPTION
KIT	E-6078	CAMSHAFT REPAIR KIT - SERVICES 1 WHEEL
KIT	KIT8078	CAMSHAFT REPAIR KIT FOR Q AND QPLUS WITH BOLT ON METAL BUSHING - SERVICES 1 WHEEL
KIT	E-1816SHD	BRAKE HARDWARE KIT 'P' BRAKE WITH CIRCLIP ANCHOR PINS.
KIT	E-8466AU	BRAKE HARDWARE KIT 'P' BRAKE WITH LONG BOLT-ON ANCHOR PINS WITH KNURLED ROLLERS
KIT	E-8465AU	BRAKE HARDWARE KIT 'P' BRAKE - SAME AS E-8466AU BUT SMOOTH ROLLERS
KIT	KIT8000HD**	BRAKE HARDWARE KIT 'Q' BRAKE WITH STD ROLLER RETAINER
KIT	E-2769HD	BRAKE HARDWARE KIT 'Q' BRAKE WITH STD ROLLER RETAINER
KIT	PKSMA2124515P**	4515P - MAJOR BRAKE SHOE KIT - CONSISTS OF 2 LINED SHOES & HARDWARE KIT - SERVICES 1 WHEEL.
KIT	EKSMG2A4515PHD*	4515P - MAJOR BRAKE SHOE KIT - CONSISTS OF 2 LINED SHOES & HARDWARE KIT - SERVICES 1 WHEEL.
KIT	PKSMA2124515PSS**	4515P - SHOE WITH WELDED WASHERS AND SMOOTH ROLLERS - MAJOR BRAKE SHOE KIT - CONSISTS OF 2 LINED SHOES & HARDWARE KIT - SERVICES 1 WHEEL.
KIT	EKSMG2A4515PSS*	4515P - SHOE WITH WELDED WASHERS AND SMOOTH ROLLERS - MAJOR BRAKE SHOE KIT - CONSISTS OF 2 LINED SHOES & HARDWARE KIT - SERVICES 1 WHEEL.
KIT	EKSMG2A4515PSSK*	4515P - SHOE WITH WELDED WASHERS AND KNURLED ROLLERS - MAJOR BRAKE SHOE KIT - CONSISTS OF 2 LINED SHOES & HARDWARE KIT - SERVICES 1 WHEEL.
KIT	KSMA2124515Q**	4515Q - MAJOR BRAKE SHOE KIT - CONSISTS OF 2 LINED SHOES & HARDWARE KIT - SERVICES 1 WHEEL.
KIT	EKSMG2A4515Q*	4515Q - MAJOR BRAKE SHOE KIT - CONSISTS OF 2 LINED SHOES & HARDWARE KIT - SERVICES 1 WHEEL.
KIT	KSMA2124707QP**	4707QP - MAJOR BRAKE SHOE KIT - CONSISTS OF 2 LINED SHOES & HARDWARE KIT - SERVICES 1 WHEEL.
KIT	EKSMG2A4707QP*	4707QP - MAJOR BRAKE SHOE KIT - CONSISTS OF 2 LINED SHOES & HARDWARE KIT - SERVICES 1 WHEEL.

\* Please contact Customer Service for details on other grades of friction material available.

\*\* Restricted sale.

# MERITOR TN METRIC AXLE

CAST BRAKE SPIDER / STEPPED CAMSHAFTS TO JUNE 1991  
16-1/2" x 7" BRAKES

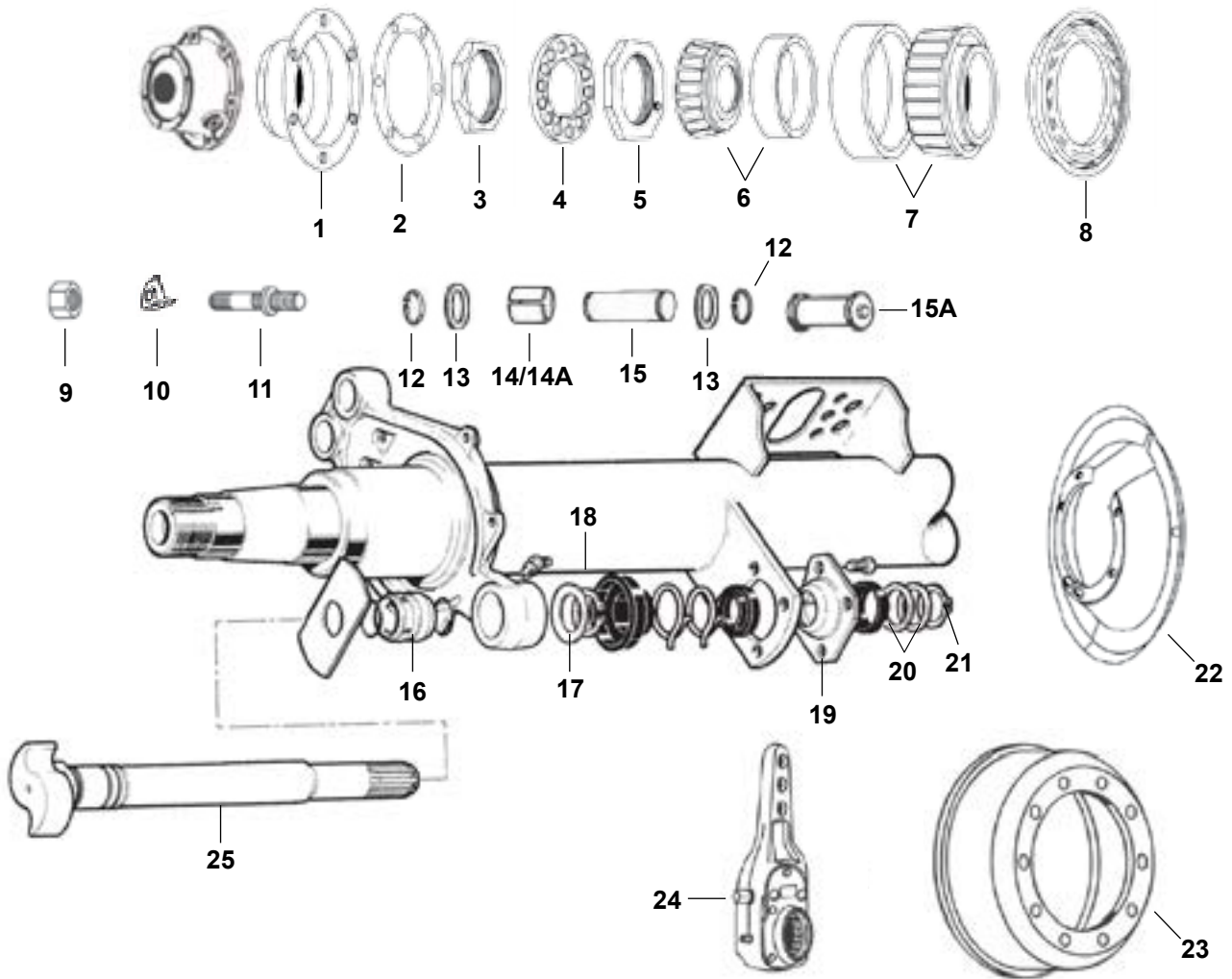

"Q" TYPE BRAKE

H/D RETAINER OPTION

"P" TYPE BRAKE

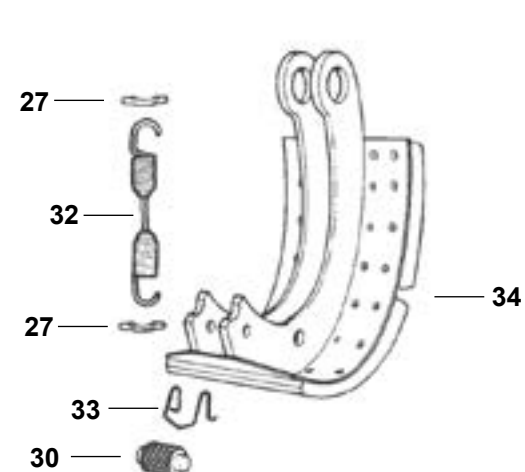
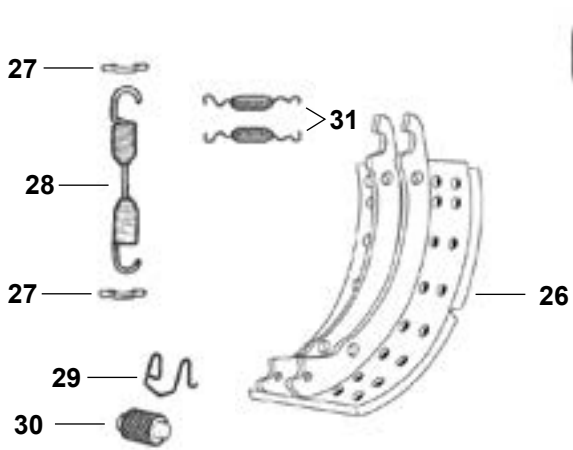

# MERITOR TN METRIC AXLE

CAST BRAKE SPIDER / STEPPED CAMSHAFTS TO JUNE 1991  
16-1/2" x 7" BRAKES

ITEM NUMBER	PART NUMBER	DESCRIPTION
1	E-975	HUB CAP GREASE
2	E-03009	GASKET - HUB CAP
3	21210819	OUTER AXLE NUT - AXLE NUT KIT
4	21020818	LOCK WASHER - AXLE NUT KIT
5	21205571	INNER AXLE NUT - AXLE NUT KIT
6	MERSET414	INNER BEARING SET (HM/218248/HM218210)
7	MERSET413	OUTER BEARING SET (HM212049/HM212011)
8	MER0143	AXLE SEAL GREASE
9	E-7775	WHEEL NUT
10	E-5571A	WHEEL CLAMP (FOR 5/6 SPOKE HUBS ONLY)
11	R004956A	WHEEL STUD
12	1229X1116	CIRCLIP - TO SUIT 1-1/4" SHAFT
13	E-1113	WASHER - 1-7/8" OD X 1-1/4" ID X 1-1/16"
14	E-1893	ANCHOR PIN BUSH - STAINLESS STEEL
14A	1225B496	ANCHOR PIN BUSH - BRONZE LINED
15	1259M1131	ANCHOR PIN - STANDARD (CIRCLIP TYPE)
15A	-	ANCHOR PIN - BOLT ON TYPE LONG (NOT SOLD SEPARATELY - PART OF KITS E-8465AU & E-8466AU)
16	21209990PK10	OUTER CAM BUSH (INC. IN AXL132 REPAIR KIT)
17	1229X3118	WASHER - 2" OD X 1-5/8" ID X 1/16"
18	E-1569	CAMSHAFT LOCK RING
19	15213430	BRACKET & BUSH ASSEMBLY
20	E-580	WASHER - 2.25" OD X 1.53" ID X 0.06"
21	1229Z1118	CIRCLIP
22	E-886	DUST COVER
23	03-122222-002	BRAKE DRUM 11" PCD 9.44" SPIGOT 5 & 6 BOLT HOLES
24	E-612SBK	SLACK AJUSTER - 3 HOLE, 10 SPLINE
25	21219257S	S CAM LH 10 SPLINE
25	21219258S	S CAM RH 10 SPLINE
26	R4515	UNLINED BRAKE SHOE (LINING REF. 4515E)
26	-	LINED BRAKE SHOE (NOT SOLD SEPARATELY - PART OF KIT EKSMG2A4515Q)
27	E-747	SPRING RETAINER
28	2258W803	RETURN SPRING - 1 PER WHEEL 'Q' BRAKE
29	3105B210	ROLLER RETAINER
30	2297T7222	ROLLER, SMOOTH
30	E-2177	ROLLER, KNURLED
30	E-2215	ROLLER, KNURLED 1/8" OVERSIZE

\* Please contact Customer Service for details on other grades of friction material available.

\*\* Restricted sale.

More Parts Next Page 



# MERITOR TN METRIC AXLE

CAST BRAKE SPIDER / STEPPED CAMSHAFTS TO JUNE 1991  
16-1/2" x 7" BRAKES

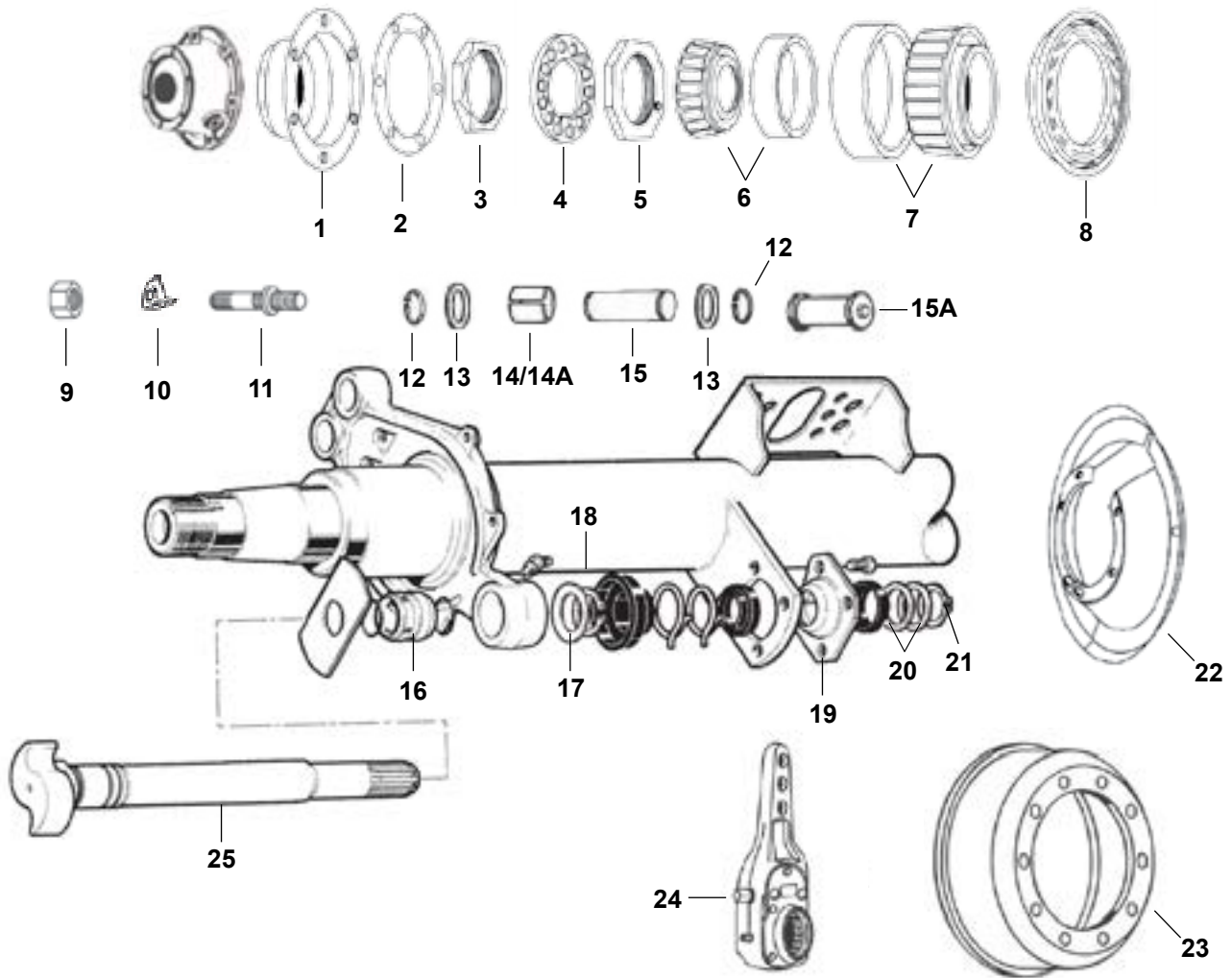

"Q" TYPE BRAKE

H/D RETAINER OPTION

"P" TYPE BRAKE

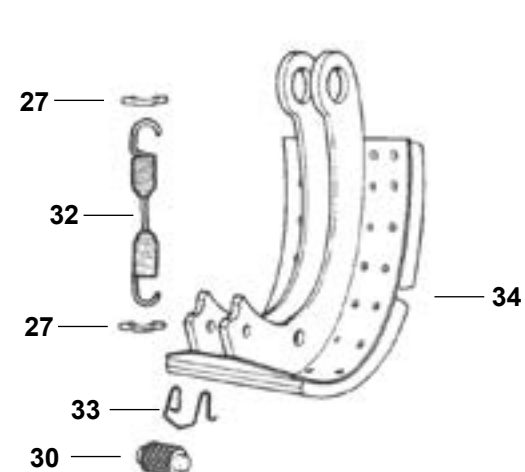
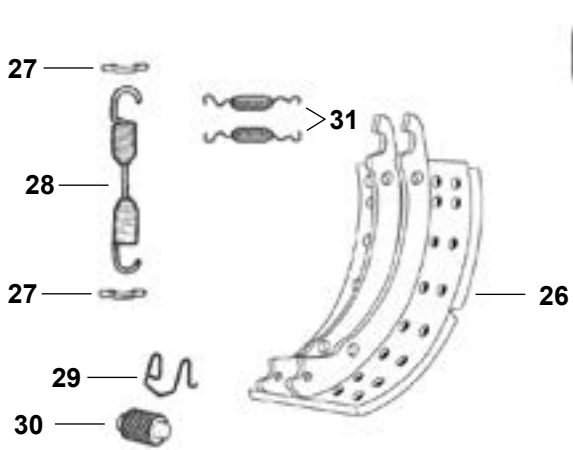

# MERITOR TN METRIC AXLE

CAST BRAKE SPIDER / STEPPED CAMSHAFTS TO JUNE 1991  
16-1/2" x 7" BRAKES

ITEM NUMBER	PART NUMBER	DESCRIPTION
30	E-781	ROLLER, SMOOTH 1/8" OVERSIZE
30	E-586	ROLLER, SMOOTH 1/4" OVERSIZE
31	E-2767	RETAINING SPRING - 2 PER WHEEL 'Q' BRAKE
32	E-1880B	RETURN SPRING - 1 PER WHEEL P BRAKE
33	E-539	ROLLER RETAINER
34	E-2241	UNLINED BRAKE SHOE 'P' TYPE
34	-	LINED BRAKE SHOE (NOT SOLD SEPARATELY - PART OF KIT EKSMG2A4515PHD)
35	-	BOLT-ON ROLLER RETAINER KIT (NOT SOLD SEPARATELY - PART OF KITS E-8465AU & E-8466AU)

KIT	E-1816SHD	BRAKE KIT 'P' BRAKE WITH CIRCLIP ANCHOR PINS.
KIT	KIT8000HD**	BRAKE KIT 'Q' BRAKE WITH STANDARD ROLLER RETAINER
KIT	E-2769HD	BRAKE KIT 'Q' BRAKE WITH STANDARD ROLLER RETAINER
KIT	AXL132	S CAM BUSH KIT
KIT	E-04000	PLUG
KIT	E-8466AU	BRAKE KIT 'P' BRAKE WITH LONG BOLT-ON ANCHOR PINS.
KIT	E-8465AU	BRAKE KIT 'P' BRAKE - SAME AS E-8466AU BUT SMOOTH ROLLERS
KIT	EKSMG2A4515PHD*	4515P - MAJOR BRAKE SHOE KIT - CONSISTS OF 2 LINED SHOES & HARDWARE KIT - SERVICES 1 WHEEL.
KIT	EKSMG2A4515PSS*	4515P - SHOE WITH WELDED WASHERS AND SMOOTH ROLLERS - MAJOR BRAKE SHOE KIT - CONSISTS OF 2 LINED SHOES & HARDWARE KIT - SERVICES 1 WHEEL.
KIT	EKSMG2A4515PSSK*	4515P - SHOE WITH WELDED WASHERS AND KNURLED ROLLERS - MAJOR BRAKE SHOE KIT - CONSISTS OF 2 LINED SHOES & HARDWARE KIT - SERVICES 1 WHEEL.
KIT	PKSMA2124515P**	4515-P MAJOR BRAKE SHOE KIT - CONSISTS OF 2 LINED SHOES & HARDWARE KIT - SERVICES 1 WHEEL.
KIT	PKSMA2124515PSS**	4515-P (WITH WELDED WASHER) MAJOR BRAKE SHOE KIT - CONSISTS OF 2 LINED SHOES & HARDWARE KIT - SERVICES 1 WHEEL.
KIT	EKSMG2A4515Q*	4515-Q MAJOR BRAKE SHOE KIT - CONSISTS OF 2 LINED SHOES & HARDWARE KIT - SERVICES 1 WHEEL.
KIT	KSMA2124515Q**	4515-Q MAJOR BRAKE SHOE KIT - CONSISTS OF 2 LINED SHOES & HARDWARE KIT - SERVICES 1 WHEEL.

\* Please contact Customer Service for details on other grades of friction material available.

\*\* Restricted sale.



# MERITOR™ METRIC AXLE

FABRICATED BRAKE SPIDER / STEPPED CAMSHAFTS FROM JUNE 1991  
16-1/2" x 7" BRAKES

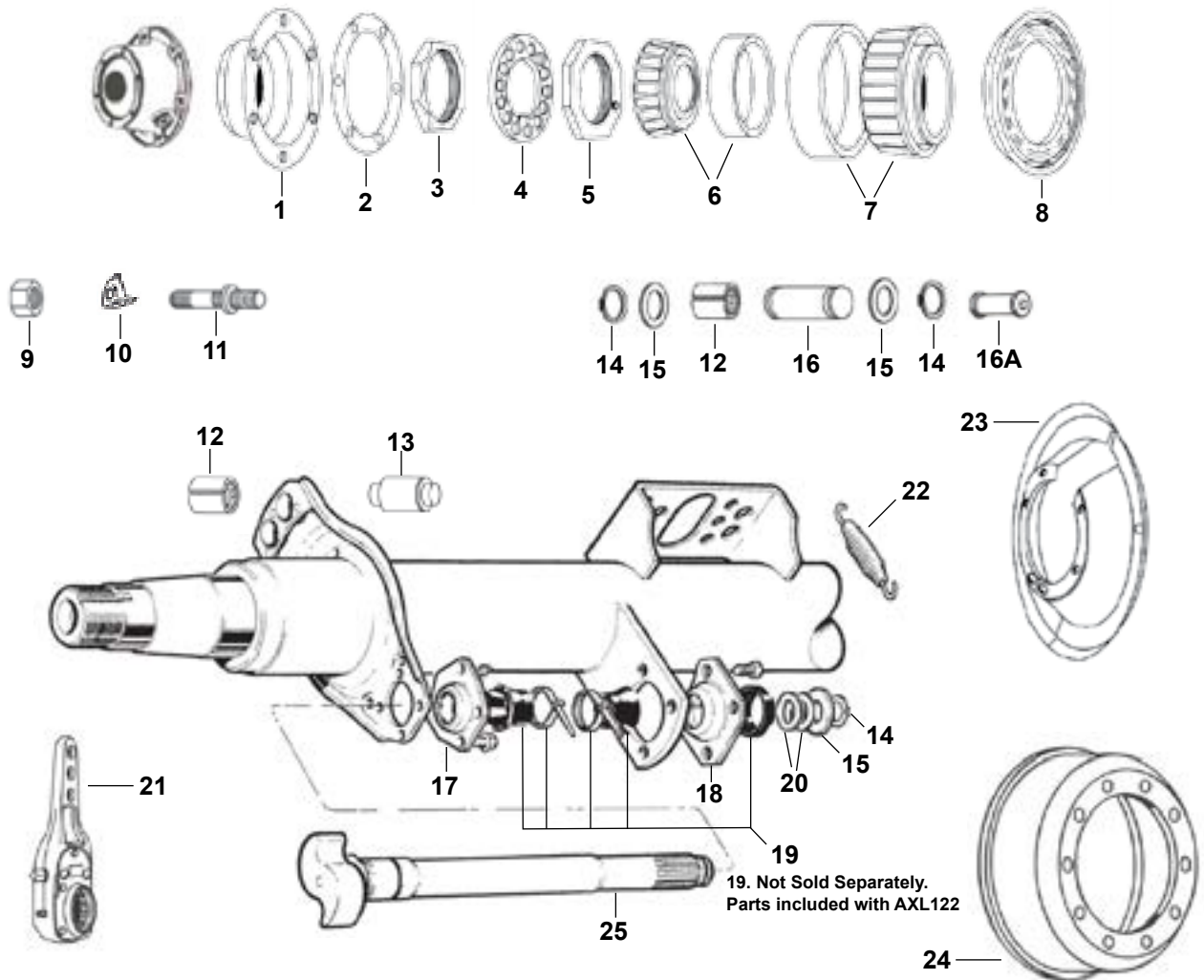

## "Q" TYPE BRAKE

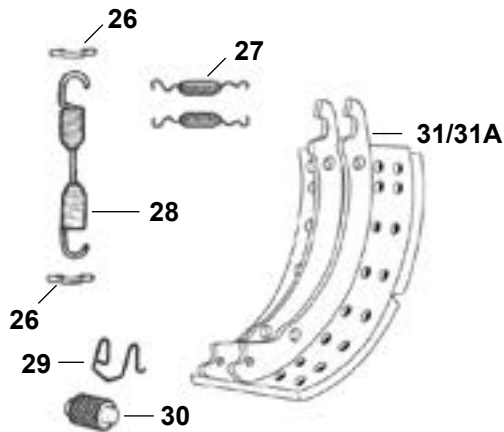

## H/D RETAINER OPTION



## "P" TYPE BRAKE

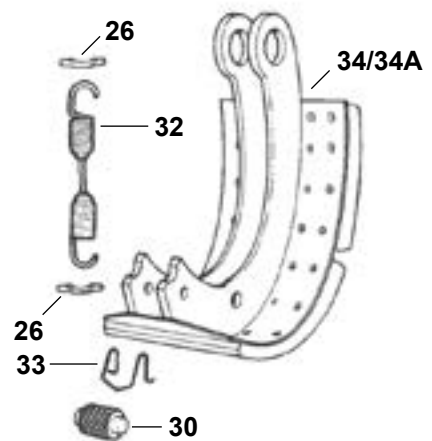

# MERITOR™ METRIC AXLE

FABRICATED BRAKE SPIDER / STEPPED CAMSHAFTS FROM JUNE 1991  
16-1/2" x 7" BRAKES

ITEM NUMBER	PART NUMBER	DESCRIPTION
1	E-975	HUB CAP GREASE
2	E-03009	GASKET - HUB CAP
3	21210819	OUTER AXLE NUT - AXLE NUT KIT
4	21020818	OUTER AXLE NUT - AXLE NUT KIT
5	21205571	OUTER AXLE NUT - AXLE NUT KIT
6	MERSET414	INNER BEARING SET (HM/218248/HM218210)
7	MERSET413	OUTER BEARING SET (HM212049/HM212011)
8	MER0143	AXLE SEAL GREASE
9	E-7775	WHEEL NUT
10	E-5571A	WHEEL CLAMP (FOR 5/6 SPOKE HUBS ONLY)
11	R004956A	WHEEL STUD
12	E-1893	ANCHOR PIN BUSH - STAINLESS STEEL
12	1225B496	ANCHOR PIN BUSH - BRONZE LINED
13	1259N274	Q' BRAKE ANCHOR PIN
14	1229X1116	CIRCLIP - TO SUIT 1-1/4" SHAFT
15	E-1113	WASHER - 1-7/8" OD X 1-1/4" ID X 1-1/16"
16	1259M1131	ANCHOR PIN - STANDARD (CIRCLIP TYPE)
16A	-	ANCHOR PIN - BOLT ON TYPE LONG (NOT SOLD SEPARATELY - PART OF KIT E-1816SHD)
17	15224821	OUTER CAM BUSH ASSEMBLY
18	15213430	BRACKET & BUSH ASSEMBLY
19	AXL122	S CAM BUSH KIT
20	E-580	WASHER - 2.25" OD X 1.53" ID X 0.06"
21	E-612SBK	SLACK AJUSTER - 3 HOLE, 10 SPLINE
22	21210215PK10	SPRING EXT/L BRAKE RETUR
23	E-886	DUST COVER
24	03-122222-002	BRAKE DRUM 11" PCD 9.44" SPIGOT 5 & 6 BOLT HOLES
25	TBA	S' CAM LH, 10 SPLINE
25	TBA	S' CAM RH, 10 SPLINE
26	E-747	SPRING RETAINER
27	E-2767	RETAINING SPRING - 2 PER WHEEL 'Q' BRAKE
28	2258W803	RETURN SPRING - 1 PER WHEEL 'Q' BRAKE
29	3105B210	ROLLER RETAINER
30	2297T7222	ROLLER, SMOOTH
30	E-2177	ROLLER, KNURLED

More Parts Next Page 



# MERITOR™ METRIC AXLE

FABRICATED BRAKE SPIDER / STEPPED CAMSHAFTS FROM JUNE 1991  
16-1/2" x 7" BRAKES

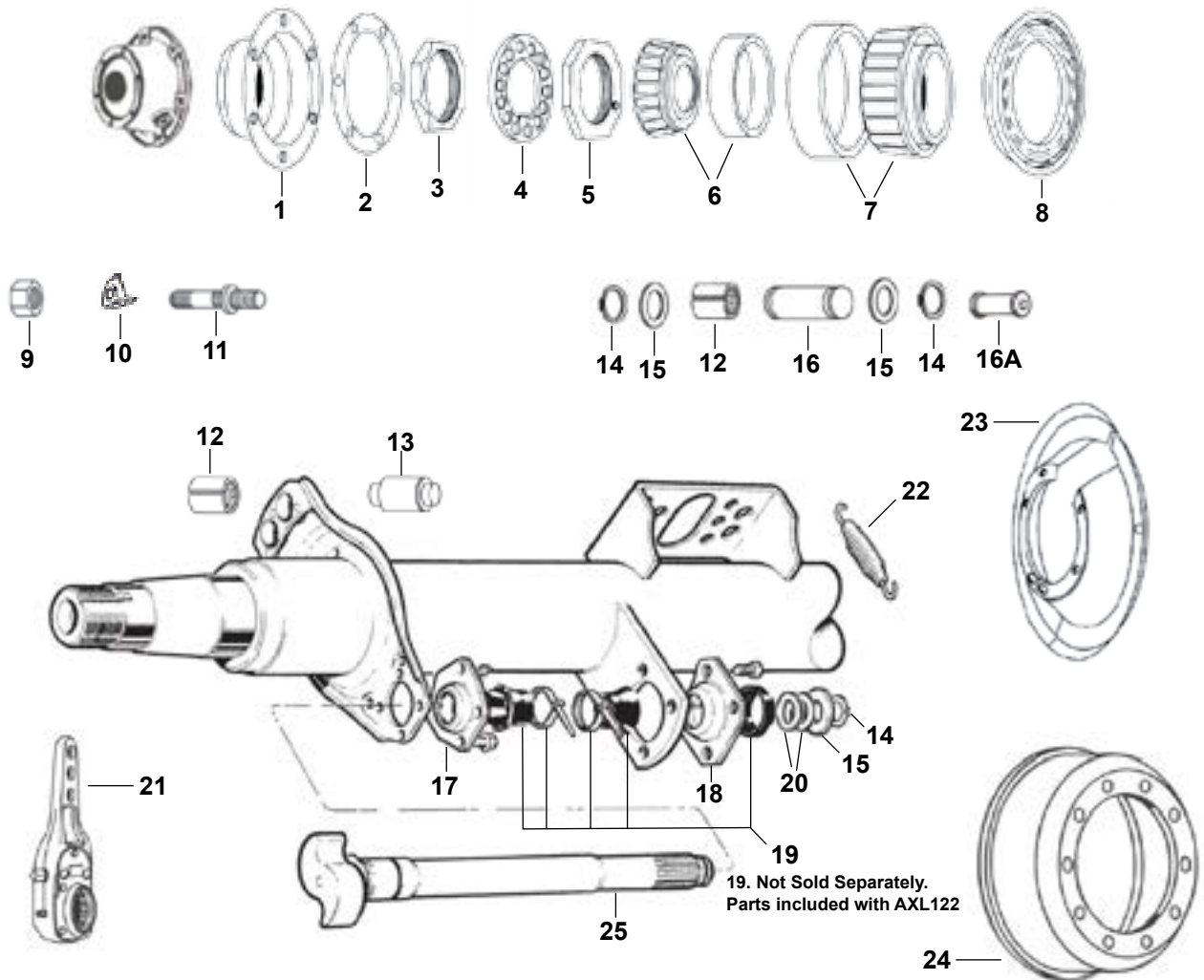

## "Q" TYPE BRAKE

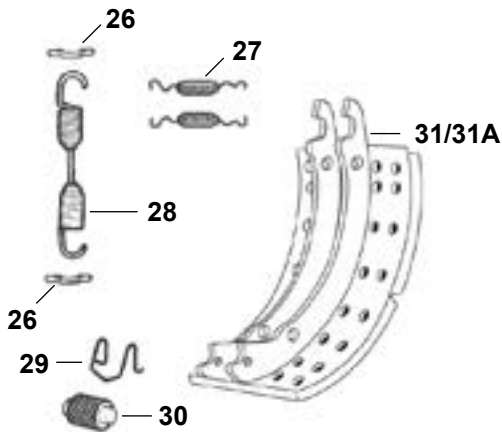

## H/D RETAINER OPTION



## "P" TYPE BRAKE

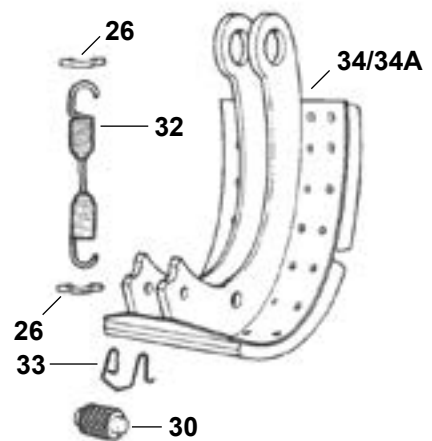



# MERITOR™ METRIC AXLE

FABRICATED BRAKE SPIDER / STEPPED CAMSHAFTS FROM JUNE 1991  
16-1/2" x 7" BRAKES

ITEM NUMBER	PART NUMBER	DESCRIPTION
30	E-2215	ROLLER, KNURLED 1/8" OVERSIZE
30	E-781	ROLLER, SMOOTH 1/8" OVERSIZE
30	E-586	ROLLER, SMOOTH 1/4" OVERSIZE
31	R4515	UNLINED BRAKE SHOE (LINING REF. 4515E)
31A	-	LINED BRAKE SHOE (NOT SOLD SEPARATELY - PART OF KIT EKSMG2A4515Q)
32	E-1880B	RETURN SPRING - 1 PER WHEEL P BRAKE
33	E-539	ROLLER RETAINER
34	E-2241	UNLINED BRAKE SHOE 'P' TYPE
34A	-	LINED BRAKE SHOE (NOT SOLD SEPARATELY - PART OF KIT EKSMG2A4515PHD)
35	-	BOLT-ON ROLLER RETAINER KIT (NOT SOLD SEPARATELY - PART OF KITS E-8465AU & E-8466AU)

KIT	E-1816SHD	BRAKE KIT 'P' BRAKE WITH CIRCLIP ANCHOR PINS.
KIT	E-8466AU	BRAKE KIT 'P' BRAKE WITH LONG BOLT-ON ANCHOR PINS.
KIT	E-8465AU	BRAKE KIT 'P' BRAKE - SAME AS E-8466AU BUT SMOOTH ROLLERS
KIT	KIT8000HD**	BRAKE KIT 'Q' BRAKE WITH STANDARD ROLLER RETAINER
KIT	E-2769HD	BRAKE KIT 'Q' BRAKE WITH STANDARD ROLLER RETAINER
KIT	KSMA2124515Q**	4515-Q MAJOR BRAKE SHOE KIT - CONSISTS OF 2 LINED SHOES & HARDWARE KIT - SERVICES 1 WHEEL.
KIT	EKSMG2A4515Q*	4515-Q MAJOR BRAKE SHOE KIT - CONSISTS OF 2 LINED SHOES & HARDWARE KIT - SERVICES 1 WHEEL.
KIT	PKSMA2124515P**	4515-P MAJOR BRAKE SHOE KIT - CONSISTS OF 2 LINED SHOES & HARDWARE KIT - SERVICES 1 WHEEL.
KIT	EKSMG2A4515PHD*	4515-P MAJOR BRAKE SHOE KIT - CONSISTS OF 2 LINED SHOES & HARDWARE KIT - SERVICES 1 WHEEL.

\* Please contact Customer Service for details on other grades of friction material available.

\*\* Restricted sale.



# MERITOR 16 1/2" DIAMETER "Q" & "P" BRAKES

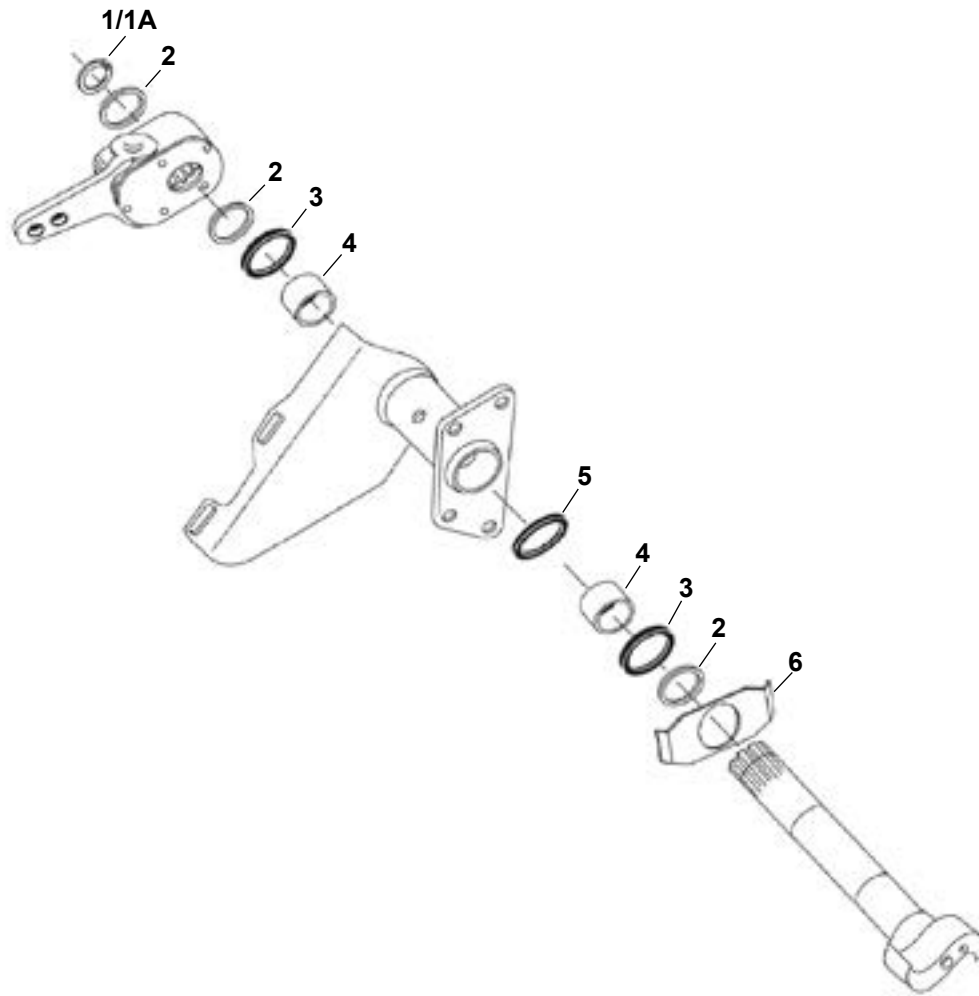

"P" BRAKE

H/D RETAINER OPTION

"Q" BRAKE

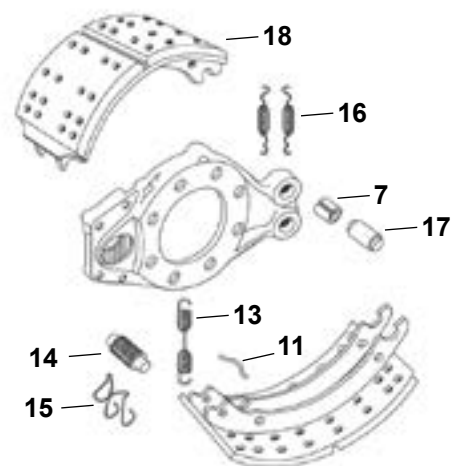
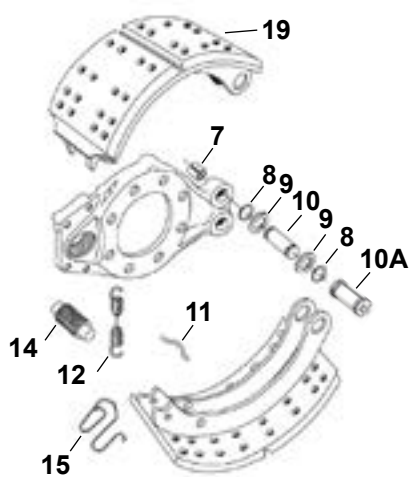

# MERITOR 16 1/2" DIAMETER

## "Q" & "P" BRAKES

ITEM NUMBER	PART NUMBER	DESCRIPTION
1	1229Z1118	CIRCLIP
1A	1229D2942	CIRCLIP 3/32" THICK
2	1229M559	WASHER
3	A1205V1556	SEAL
4	1225L1208	BUSH
5	1205G761	SEAL
6	E-656	D' WASHER
7	E-1893	ANCHOR PIN BUSH - STAINLESS STEEL
7A	1225B496	ANCHOR PIN BUSH - BRONZE LINED
8	1229X1116	CIRCLIP - TO SUIT 1-1/4" SHAFT
9	E-1113	SPACER WASHER - 1-7/8" OD X 1-7/16" X 1/16"
10	1259Q251	ANCHOR PIN, P BRAKE, CIRCLIP
10A	-	ANCHOR PIN - BOLT ON TYPE LONG (NOT SOLD SEPARATELY - PART OF KITS E-8465AU & E-8466AU)
11	E-747	SPRING RETAINER
12	E-1880B	RETURN SPRING - 1 PER WHEEL P BRAKE
13	2258W803	RETURN SPRING - "Q" / "Q PLUS"
14	2297T7222	ROLLER, SMOOTH
14	E-2177	ROLLER, KNURLED
14	E-2215	ROLLER, KNURLED 1/8" OVERSIZE
14	E-781	ROLLER, SMOOTH 1/8" OVERSIZE
14	E-586	ROLLER, SMOOTH 1/4" OVERSIZE
15	E-539	ROLLER RETAINER
15A	-	BOLT ON TYPE CAM ROLLER RETAINER (NOT SOLD SEPARATELY - PART OF KIT E-8465AU)
16	E-2767	RETAINING SPRING - 2 PER WHEEL 'Q' BRAKE
17	1259N274	Q' BRAKE ANCHOR PIN
18	R4515	BARE SHOE 7" "Q" TYPE 4515E
18	SMG2A4515Q	LINED BRAKE SHOE (NOT SOLD SEPARATELY - PART OF KIT EKSMG2A4515Q)
18	E-3303	BARE SHOE 5" "Q" TYPE 4524B
18	E-3303	PAIR OF NEW RIVETED LINED BRAKE SHOES
18	E-3304	BARE SHOE 6" "Q" TYPE 4514B

More Parts Next Page 



# MERITOR 16 1/2" DIAMETER

"Q" & "P" BRAKES

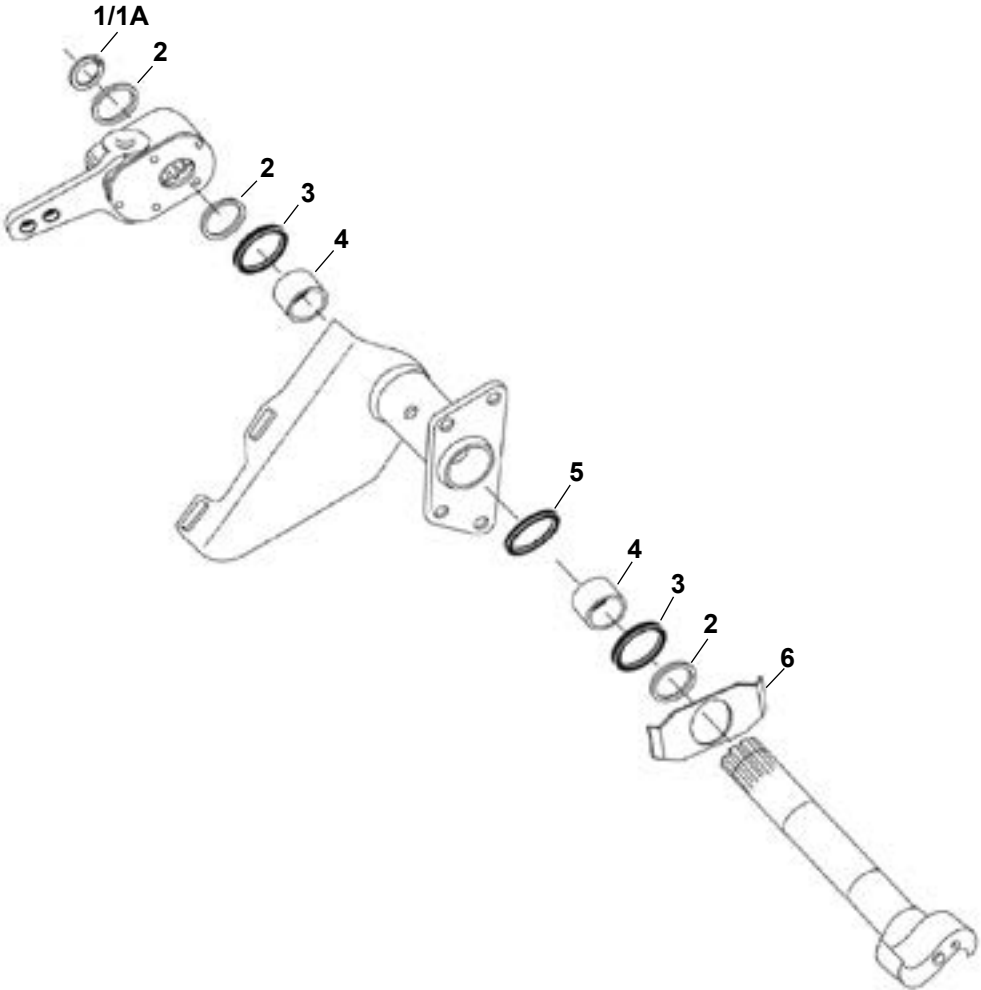

"P" BRAKE

H/D RETAINER OPTION

"Q" BRAKE

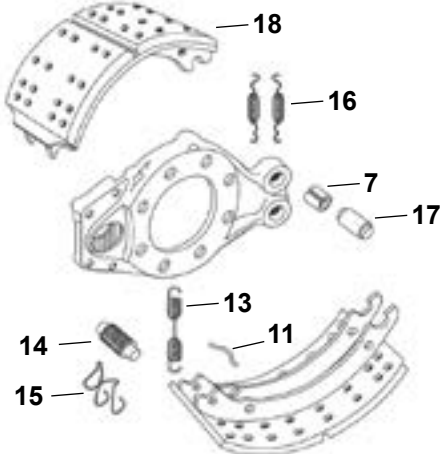
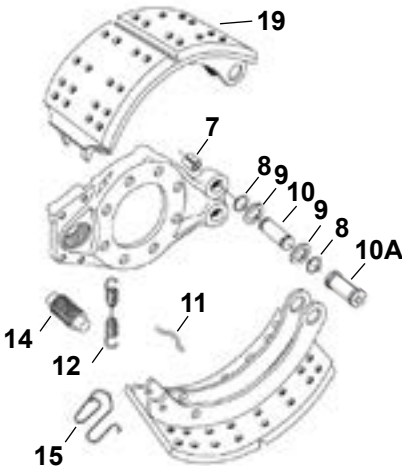

# MERITOR 16 1/2" DIAMETER

## "Q" & "P" BRAKES

ITEM NUMBER	PART NUMBER	DESCRIPTION
19	E-2241	BARE SHOE 7" "P" TYPE 4515E
19	-	LINED BRAKE SHOE (NOT SOLD SEPARATELY - PART OF KIT EKSMG2A4515PHD)
19	E-2684	BARE SHOE 6" "P" TYPE 4514B
19	A3722D82	BARE SHOE 5" "P" TYPE 4524B
19	A3722D82	PAIR OF NEW RIVETED LINED BRAKE SHOES

KIT	E-8466AU	BRAKE KIT 'P' BRAKE WITH LONG BOLT-ON ANCHOR PINS.
KIT	E-8465AU	BRAKE KIT 'P' BRAKE - SAME AS E-8466AU BUT SMOOTH ROLLERS
KIT	KIT8000HD**	BRAKE KIT 'Q' BRAKE WITH STANDARD ROLLER RETAINER
KIT	E-2769HD	BRAKE KIT 'Q' BRAKE WITH STANDARD ROLLER RETAINER
KIT	E-2287	CAMSHAFT BUSH KIT. CAMSHAFT REPAIR KIT SERVICE 1 AXLE.
KIT	E-1816SHD	BRAKE KIT 'P' BRAKE WITH CIRCLIP ANCHOR PINS.
KIT	KSMA2124515Q**	4515Q - MAJOR BRAKE SHOE KIT - CONSISTS OF 2 LINED SHOES & HARDWARE KIT - SERVICES 1 WHEEL.
KIT	EKSMG2A4515Q*	4515Q - MAJOR BRAKE SHOE KIT - CONSISTS OF 2 LINED SHOES & HARDWARE KIT - SERVICES 1 WHEEL.
KIT	PKSMA2124515P**	4515P - MAJOR BRAKE SHOE KIT - CONSISTS OF 2 LINED SHOES & HARDWARE KIT - SERVICES 1 WHEEL.
KIT	EKSMG2A4515PHD*	4515P - MAJOR BRAKE SHOE KIT - CONSISTS OF 2 LINED SHOES & HARDWARE KIT - SERVICES 1 WHEEL.

\* Please contact Customer Service for details on other grades of friction material available.

\*\* Restricted sale.



# MERITOR 15" & 16 1/2" DIAMETER

"Q" PLUS BRAKES  
STEERING & DRIVE AXLES

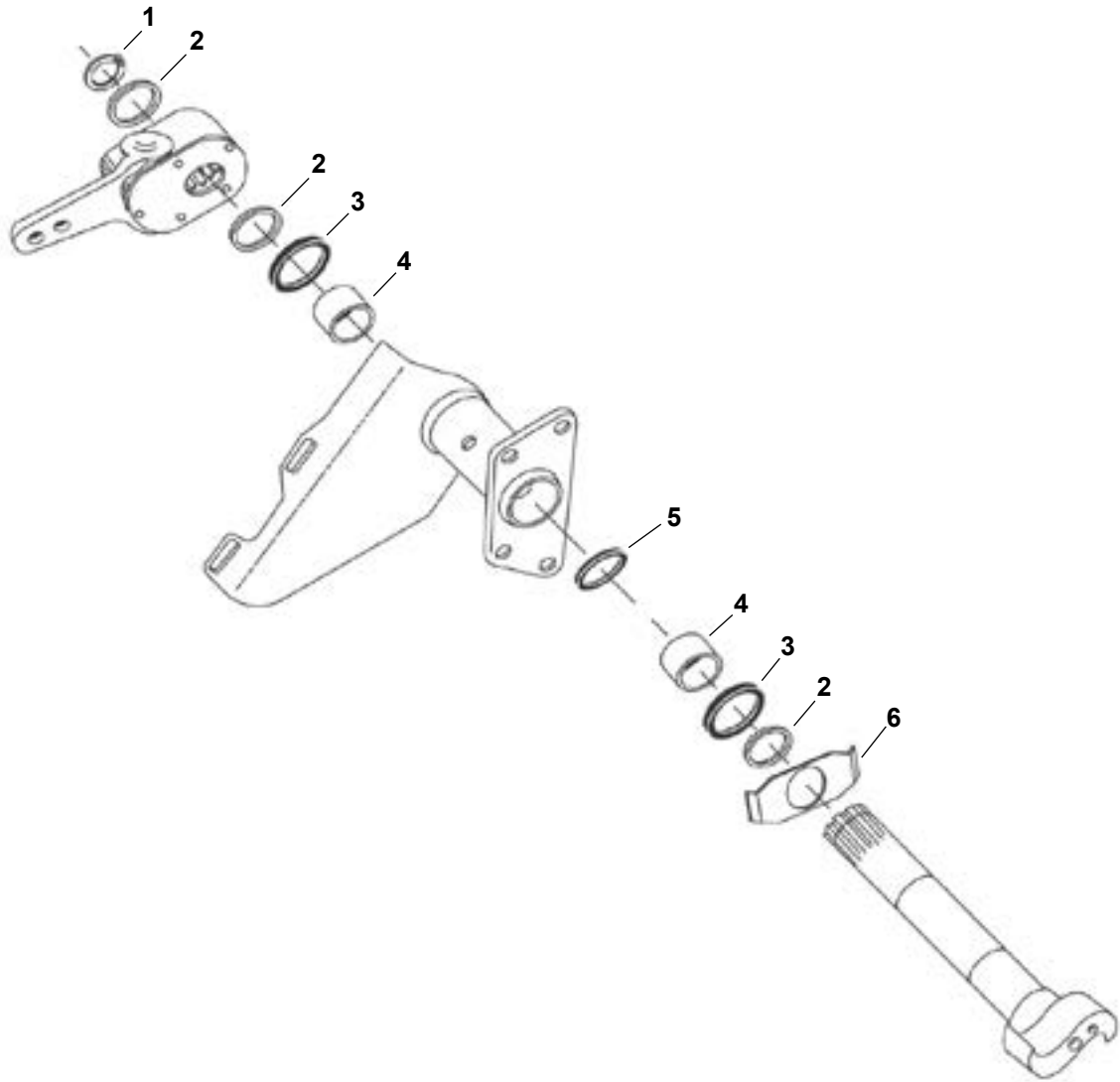

## "Q PLUS" BRAKE

H/D RETAINER OPTION

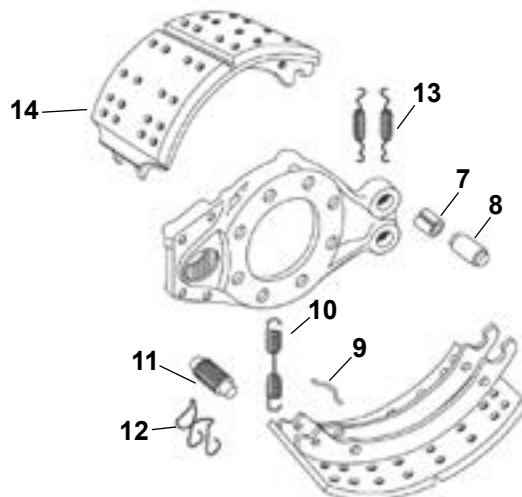

# MERITOR 15" & 16 1/2" DIAMETER

## "Q" PLUS BRAKES STEERING & DRIVE AXLES

ITEM NUMBER	PART NUMBER	DESCRIPTION
1	1229Z1118	CIRCLIP
1A	1229D2942	CIRCLIP 3/32" THICK
2	1229Q771	WASHER FLAT
2A	E-580	WASHER - 2.25" OD X 1.53" ID X0.06"
2B	E-2409	CAMSHAFT SPACER WASHER
2C	1229M559	WASHER
3	A1205V1556	SEAL
4	1225L1208	BUSH
5	1205G761	SEAL
6	E-656	D' WASHER
7	E-1893	ANCHOR PIN BUSH - STAINLESS STEEL
7A	1225B496	ANCHOR PIN BUSH - BRONZE LINED
8	1259N274	Q' BRAKE ANCHOR PIN
9	E-747	SPRING RETAINER
10	E-9063	RETURN SPRING - 15" BRAKES
10A	2258W803	RETURN SPRING - 16 1/2" BRAKES
11	2297T7222	ROLLER, SMOOTH
11	E-2177	ROLLER, KNURLED
11	E-2215	ROLLER, KNURLED 1/8" OVERSIZE
11	E-781	ROLLER, SMOOTH 1/8" OVERSIZE
11	E-586	ROLLER, SMOOTH 1/4" OVERSIZE
12	E-539	ROLLER RETAINER
12A	-	BOLT ON TYPE CAM ROLLER RETAINER (NOT SOLD SEPARATELY - PART OF KIT E-8465AU)
13	E-2767	RETAINING SPRING - 2 PER WHEEL 'Q' BRAKE
14	E-9062	BARE SHOE 15" X 4" 4702
14	-	BARE SHOE 16 1/2" X 7" 4707 - NOT SOLD SEPARATELY - PART OF KITS EKSMG2A4707QP & KSMA2124707QP)
14	-	BARE SHOE 16 1/2" X 8 5/8" 4711 - NOT SOLD SEPARATELY - PART OF KITS EKSMG2A4711QP & KSMA2124711QP)
14	A3222P2200	BARE SHOE 16 1/2" X 6" 4715
14	E-10854	BARE SHOE 16 1/2" X 5" 4720

More Parts Next Page 



# MERITOR 15" & 16 1/2" DIAMETER

"Q" PLUS BRAKES  
STEERING & DRIVE AXLES

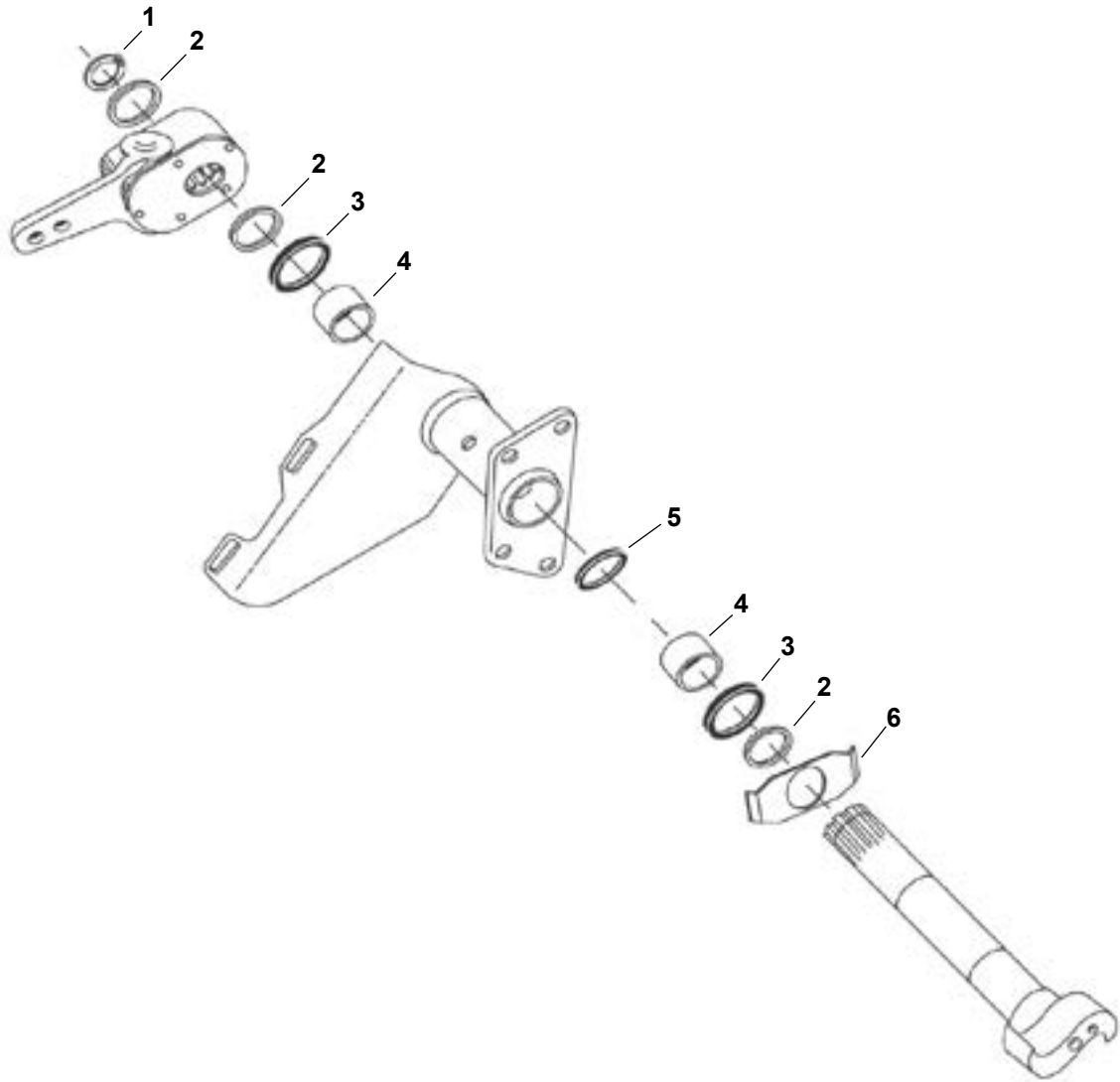

## "Q PLUS" BRAKE

H/D RETAINER OPTION

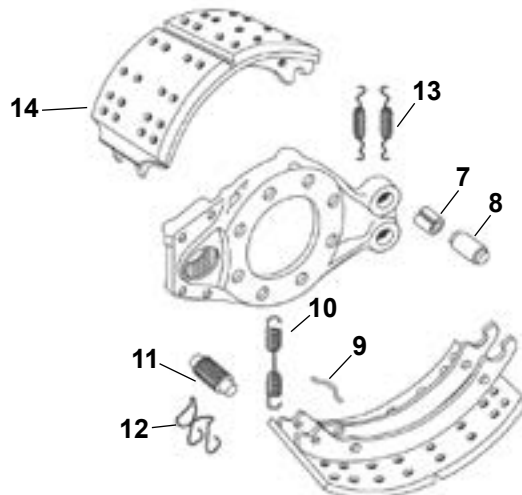



# MERITOR 15" & 16 1/2" DIAMETER

## "Q" PLUS BRAKES STEERING & DRIVE AXLES

ITEM NUMBER	PART NUMBER	DESCRIPTION
KIT	EKSMG2A4702QP*	KIT BRAKE SHOE 15" X 4"
KIT	KSMA2124702QP**	KIT BRAKE SHOE 15" X 4"
KIT	EKSMG2A4707QP*	KIT BRAKE SHOE 16 1/2" X 7"
KIT	KSMA2124707QP**	KIT BRAKE SHOE 16 1/2" X 7"
KIT	EKSMG2A4711QP*	KIT BRAKE SHOE 16 1/2" X 8 5/8"
KIT	KSMA2124711QP**	KIT BRAKE SHOE 16 1/2" X 8 5/8"
KIT	EKSMG2A4715QP*	KIT BRAKE SHOE 16 1/2" X 6"
KIT	KSMA2124715QP**	KIT BRAKE SHOE 16 1/2" X 6"
KIT	KSMA2124720QP**	KIT BRAKE SHOE 16 1/2" X 5"
KIT	EKSMG2A4720QP*	KIT BRAKE SHOE 16 1/2" X 5"
KIT	KIT8000HD**	BRAKE KIT "Q" BRAKE WITH STANDARD ROLLER RETAINER
KIT	E-2769HD	BRAKE KIT "Q" BRAKE WITH STANDARD ROLLER RETAINER
KIT	KIT9078**	CAMSHAFT BUSH KIT
KIT	E-2086B	CAMSHAFT BUSH KIT

\* Please contact Customer Service for details on other grades of friction material available.

\*\* Restricted sale.



# MERITOR 15" DIAMETER "Q" SERIES STEER AXLE BRAKE

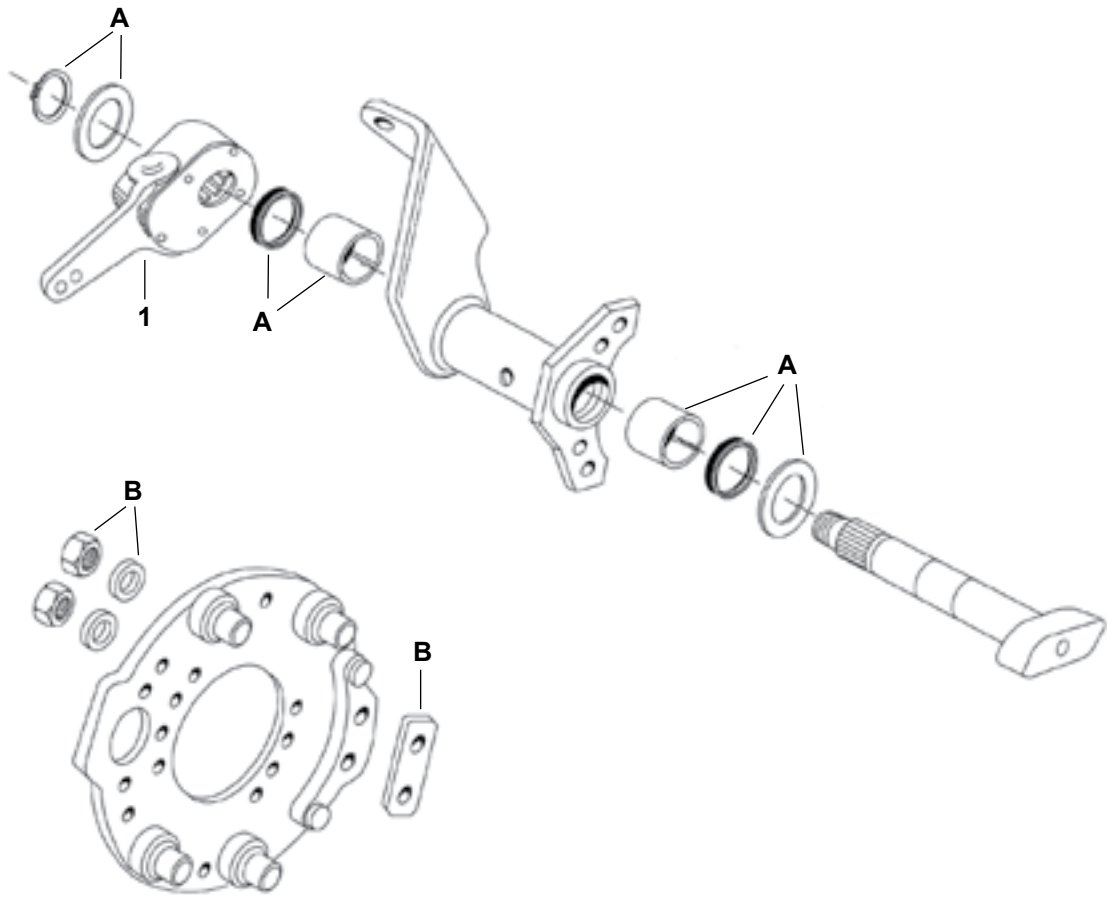

## "Q" BRAKE

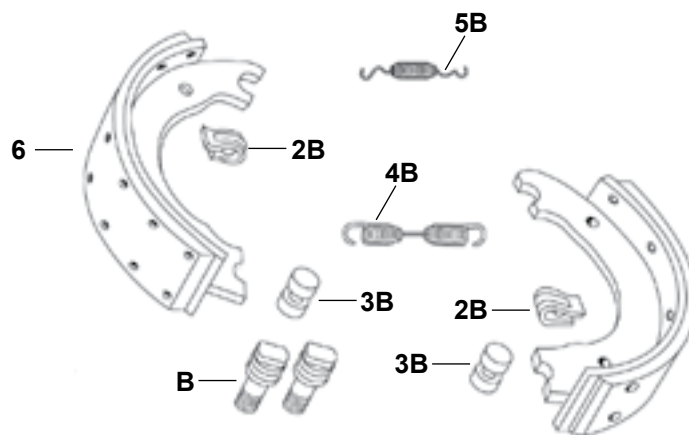

# MERITOR 15" DIAMETER "Q" SERIES

## STEER AXLE BRAKE

ITEM NUMBER	PART NUMBER	DESCRIPTION
A	E-3876	CAMSHAFT REPAIR KIT - INCLUDES ALL 'B' ITEMS AS SHOWN IN EXPLODED VIEW
B	E-1308Q	BRAKE HARDWARE KIT - INCLUDES ALL 'A' ITEMS AS SHOWN IN EXPLODED VIEW
1	-	SLACK ADJUSTER L/H - 5/8" OFFSET (NO LONGER AVAILABLE)
1	-	SLACK ADJUSTER R/H - 5/8" OFFSET (NO LONGER AVAILABLE)
2	E-2522	BRAKE SHOE HOLD DOWN KIT
3	E-3421A	ROLLER
4	2258W803	RETURN SPRING
5	2258E1123	RETAINER SPRING
6	SMG2A1308Q	UNLINED BRAKE SHOE (LINING REF. 1308)

KIT	EKSMG2A1308Q*	KIT BRAKE SHOE
KIT	KSMA2121308Q**	KIT BRAKE SHOE

\* Please contact Customer Service for details on other grades of friction material available.

\*\* Restricted sale.



# MERITOR "T" SERIES

15" DIAMETER BRAKES  
STEER AXLE BRAKE WITH 1 1/4" & 1 1/2" DIAMETER CAMSHAFT

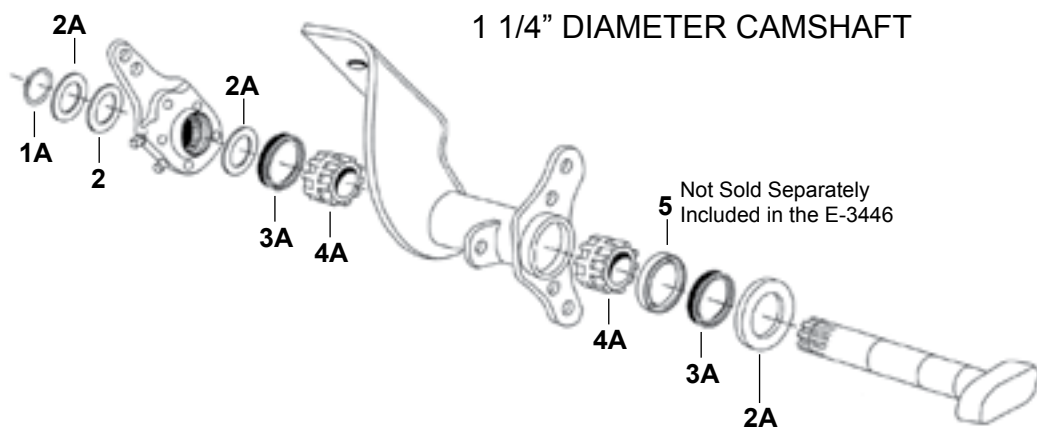
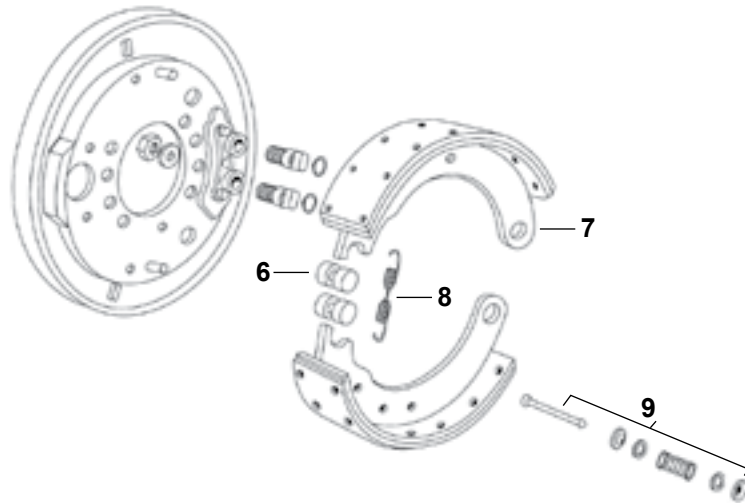
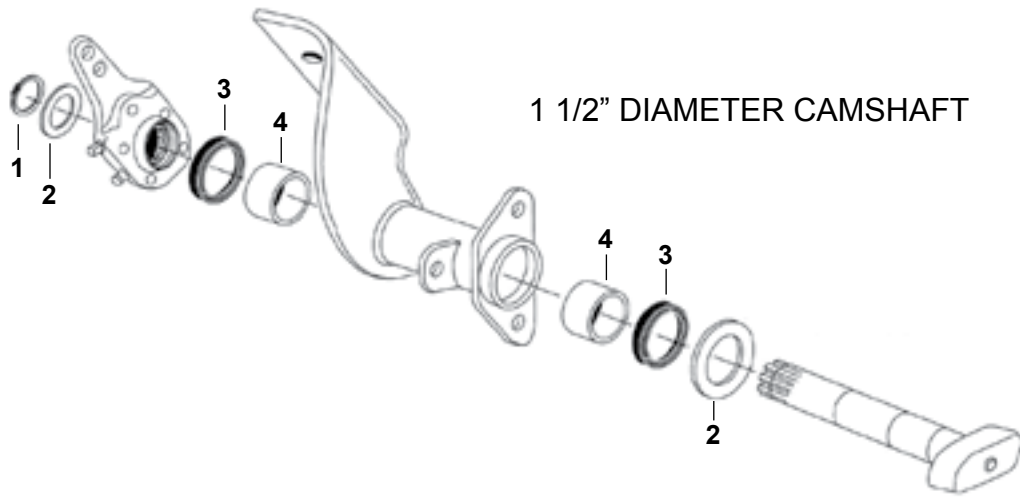

# MERITOR "T" SERIES

15" DIAMETER BRAKES

STEER AXLE BRAKE WITH 1 1/4" & 1 1/2" DIAMETER CAMSHAFT

ITEM NUMBER	PART NUMBER	DESCRIPTION
1	1229Z1118	CIRCLIP (1-1/2" CAMSHAFT)
1A	1229X1116	CIRCLIP (1-1/4" CAMSHAFT)
2	E-580	WASHER - 2.25" OD X 1.53" ID X0.06"
2A	E-1113	SPACER WASHER (1-1/4" CAMSHAFT)
3	A1205V1556	SEAL (1-1/2" CAMSHAFT)
3A	A1205P1602	SEAL (1-1/4" CAMSHAFT)
4	1225L1208	BUSH (1-1/2" CAMSHAFT)
4A	1225M897	BUSH (1-1/4" CAMSHAFT)
5	E-3446	CAM SPACER
6	E-3421A	ROLLER
7	SMG2A1308T	LINED BRAKE SHOE (LINING REF. 1308)
8	2258G579	RETURN SPRING
9	KIT1129*	SHOE HOLD DOWN KIT
KIT	EKSMG2A1308T*	KIT BRAKE SHOE
KIT	KSMA2121308T**	KIT BRAKE SHOE

\* Please contact Customer Service for details on other grades of friction material available.

\*\* Restricted sale.



# MERITOR ROCKWELL

## STOPMASTER 12° WEDGE BRAKES

15" x 3" BRAKE - STEER AXLE (BACKING PLATE MOUNTED DUAL ACTUATION)

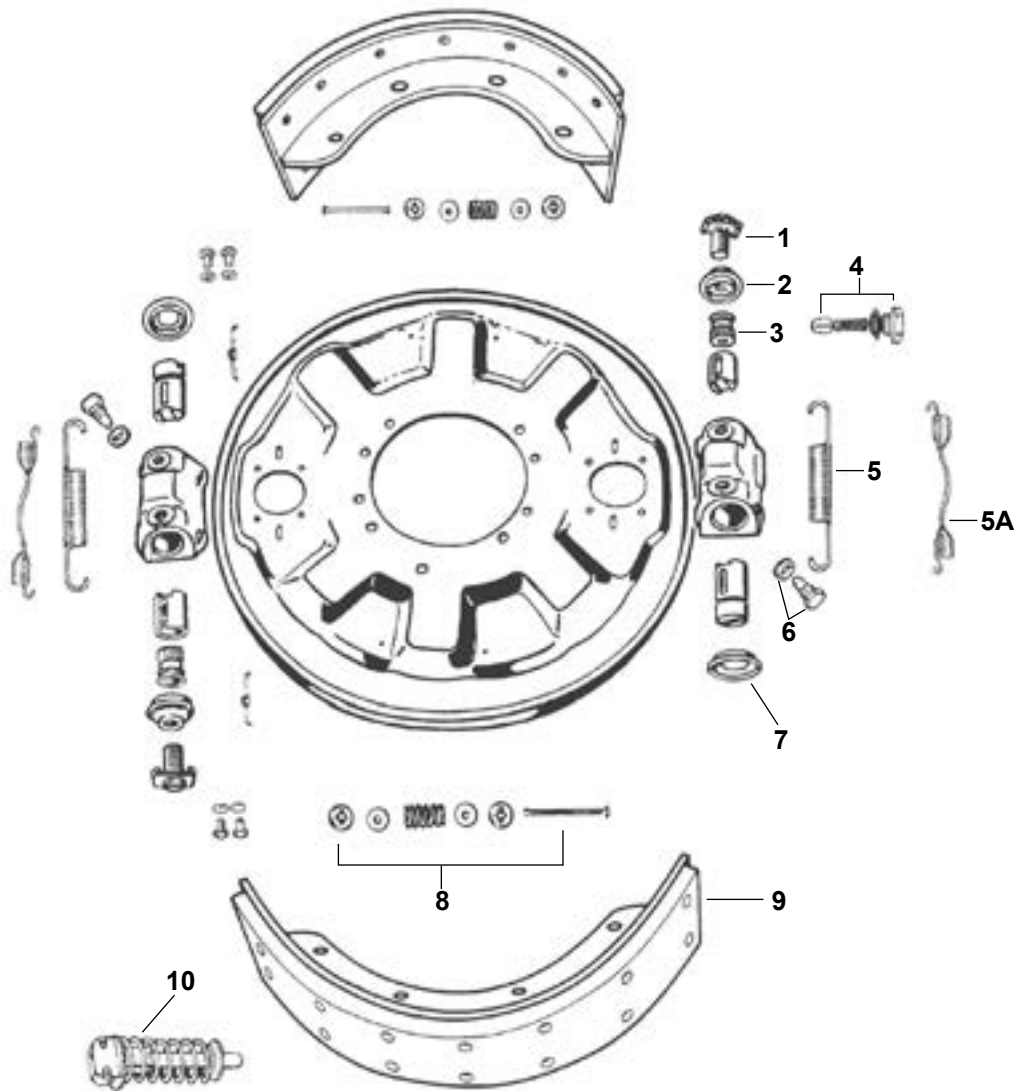

ITEM NUMBER	PART NUMBER	DESCRIPTION
1	A2297V2882	ADJUSTER SCREW
2	E-5532	ADJUSTER SEAL
3	2297N2874	ADJUSTER SLEEVE
4	E-5540	PAWL FRONT ASSEMBLY
5	E-1458	RETURN SPRING
6	E-5541	PISTON PLUNGER ASSY
7	E-5532	ANCHOR PLUNGER SEAL
8	KIT1129*	SHOE HOLD DOWN KIT
9	E-1457	UNLINED BRAKE SHOE
10	E-1261	WEDGE ASSEMBLY

\* Restricted sale.

# MERITOR ROCKWELL

## STOPMASTER 12° WEDGE BRAKES

### 15" x 7" BRAKE - DRIVE & TRAILER AXLE (BRAKE SPIDER MOUNT)

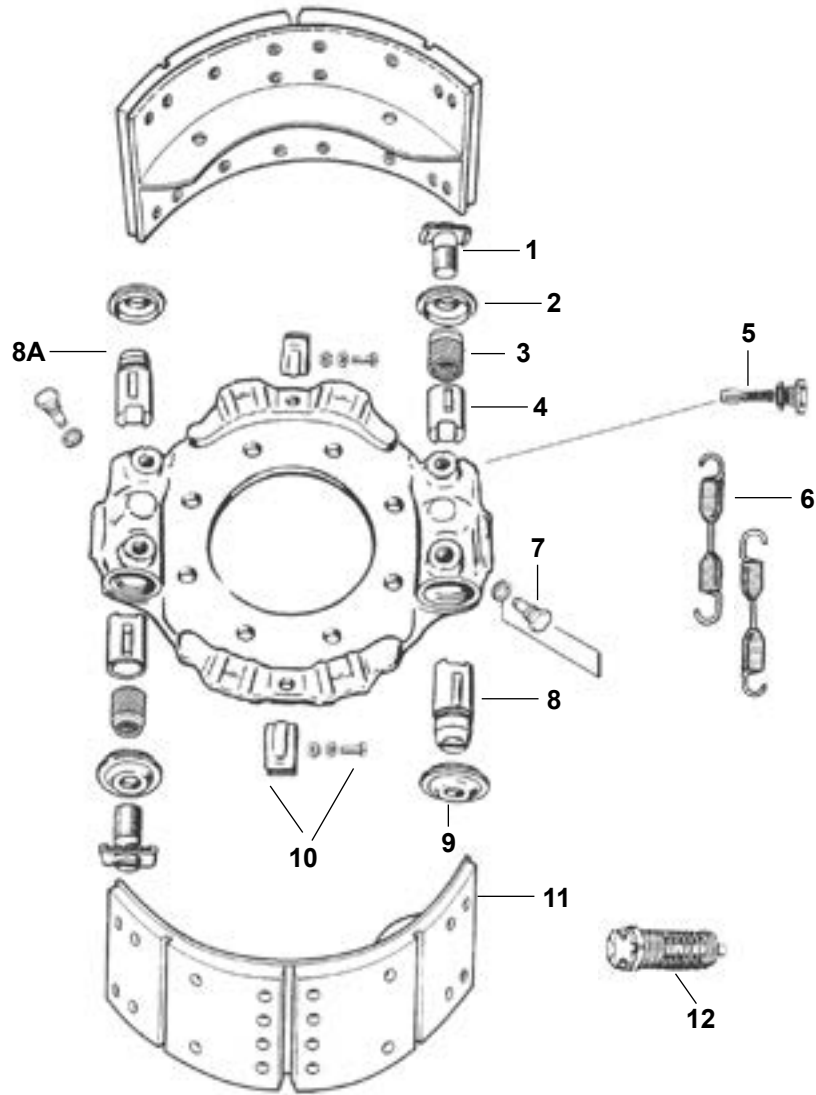

ITEM NUMBER	PART NUMBER	DESCRIPTION
1	E-2484	ADJUSTER BOLT
2	1205C2005	ADJUSTER BOLT SEAL
3	E-5531	ADJUSTER SLEEVE
4	E-3997	ADJUSTER PLUNGER
5	E-5539	NEW STYLE PAWL ASSEMBLY
6	2258H580	RETURN SPRING
7	E-5541	PLUNGER GUIDE AND WASHER
8	E-1137	ANCHOR PLUNGER L/H
8A	E-1136	ANCHOR PLUNGER R/H
9	E-3995	ANCHOR SEAL
10	E-2522	SHOE HOLD DOWN KIT
11	E-1139	UNLINED BRAKE SHOE (LINING REF. 4602)
12	E-1261	WEDGE ASSEMBLY

# AIRGLIDE

## 100 AIR GLIDE SUSPENSION

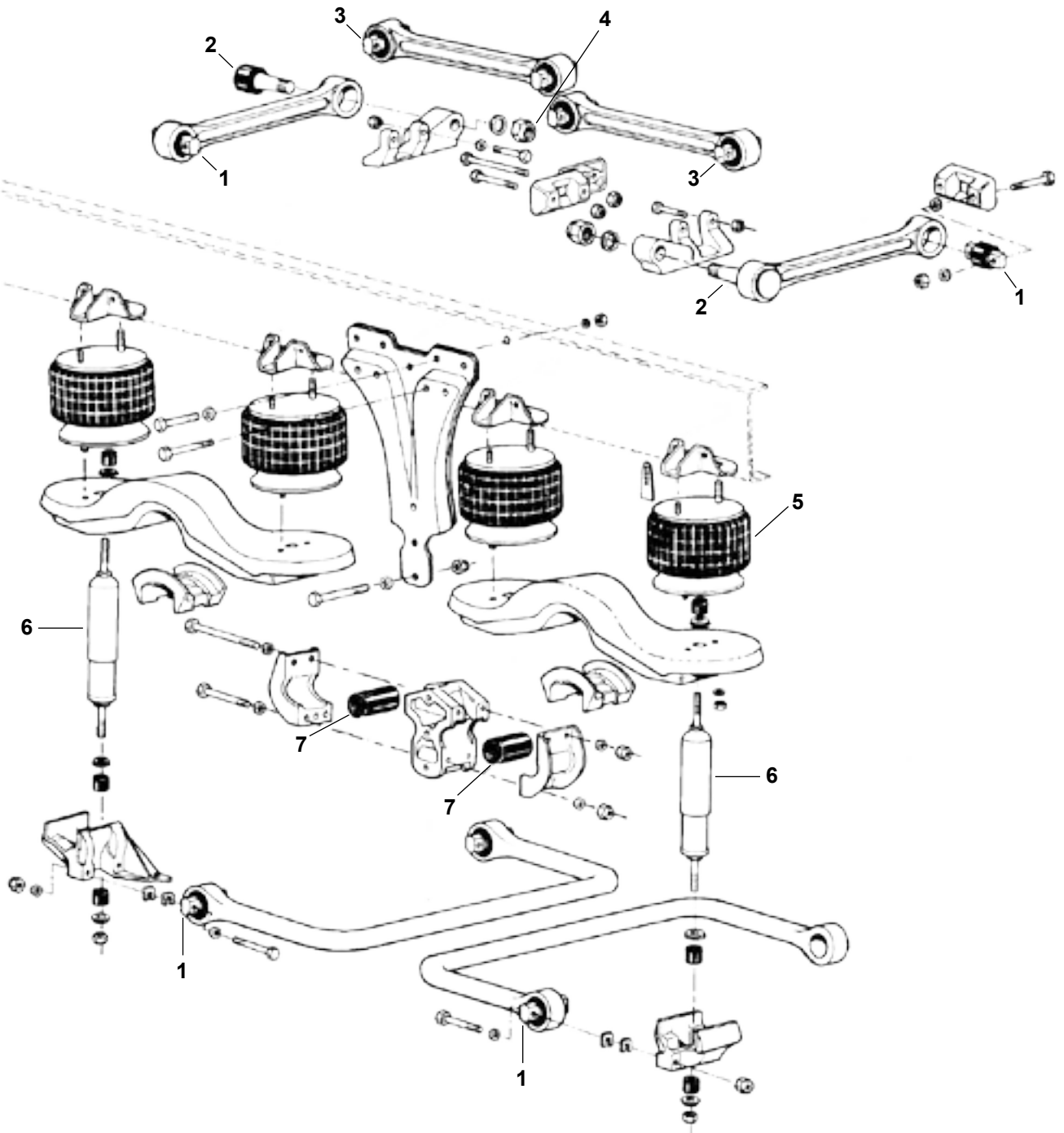



# AIRGLIDE

## 100 AIR GLIDE SUSPENSION

ITEM NUMBER	PART NUMBER	DESCRIPTION
1	R302226	TORQUE ROD BUSH (RUBBER/STEEL) SAME AS HENDRICKSON 44695 OR 44695000L
2	E-8651	TORQUE ROD BUSH (URETHANE/STEEL - TAPERED PIN)
2	R302228	TORQUE ROD BUSH (RUBBER/STEEL - TAPERED PIN) SAME AS HENDRICKSON 44697 OR 44697000L
3	E-4664	TORQUE ROD BUSH (RUBBER/STEEL/ALUMINIUM)
4	E-2017	TORQUE ARM MOUNTING NUT FOR TAPERED PIN BUSHING
5	FS9422	AIR SPRING ( REPLACES K303-6, 14 ,15)
5	FS9616	AIR SPRING ( REPLACES K303-16)
6	M85310	SHOCK ABSORBER
6	M89432	SHOCK ABSORBER - GAS
7	E-4669	STABILIZER BUSH



### Found an error?

If you detect any errors in this catalogue, please let us know. We want to ensure the information we publish is as accurate as possible. We appreciate your help in making this happen.

Please forward your enquiries to:

**Email:** [meritoraftermarketau@meritor.com](mailto:meritoraftermarketau@meritor.com)

**Phone:** (03) 8353 6050



# AIRGLIDE 200 AIR SUSPENSION

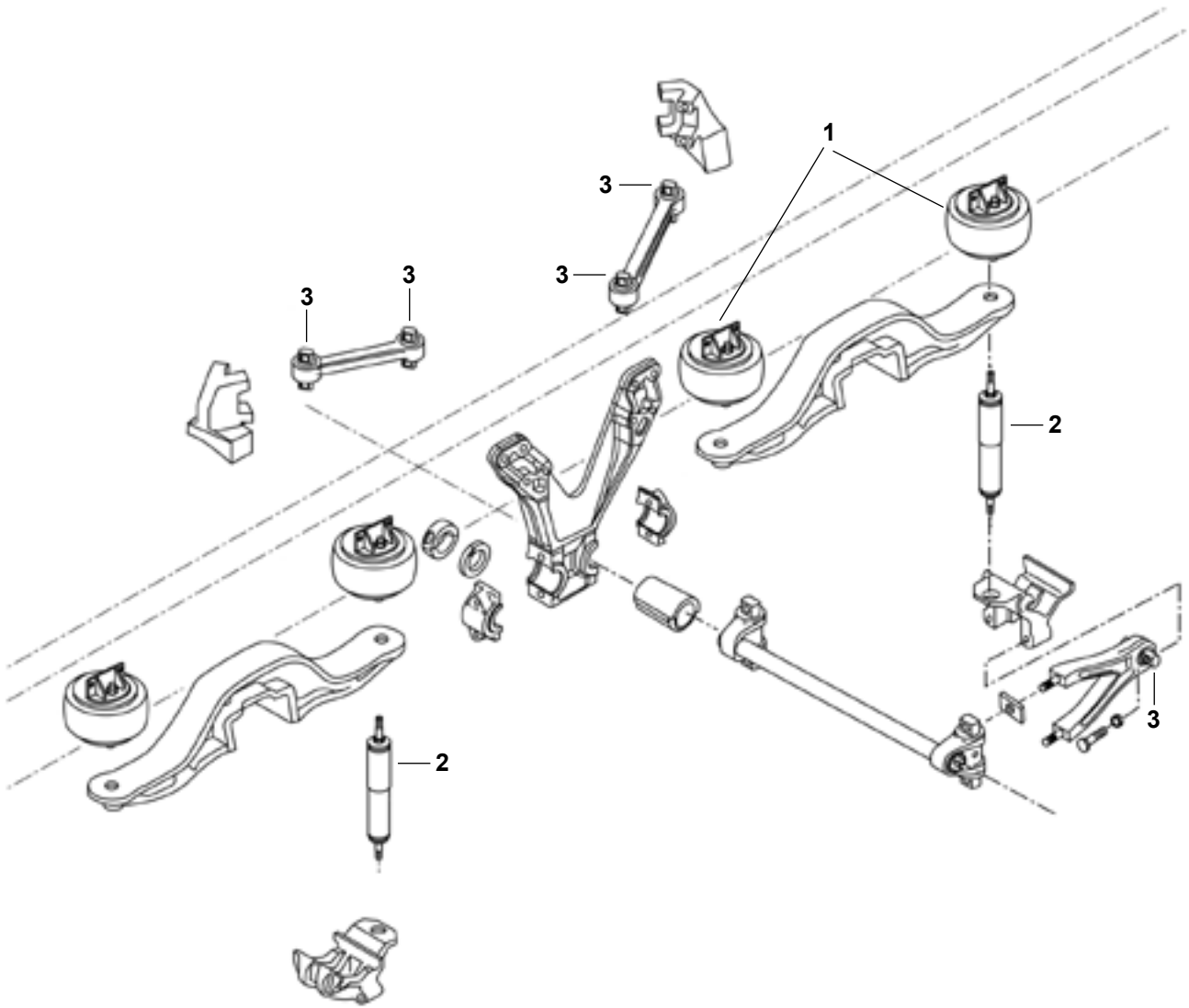

ITEM NUMBER	PART NUMBER	DESCRIPTION
1	FS9617	AIR SPRING 86 THROUGH 97 (REPLACES K303-18)
1	FS9618	AIR SPRING 86 THROUGH 97 (REPLACES K303-18)
1	FS9625	AIR SPRING 98 & UP (REPLACES K303-22)
1	FS9622	AIR SPRING 98 & UP (REPLACES K303-22)
1	FS9625	AIR SPRING 98 & UP (REPLACES K303-25)
2	M85900	SHOCK ABSORBER - GAS
3	E-10303	TORQUE ROD/SWAY BAR BUS

# FAS II AIR RIDE SUSPENSION

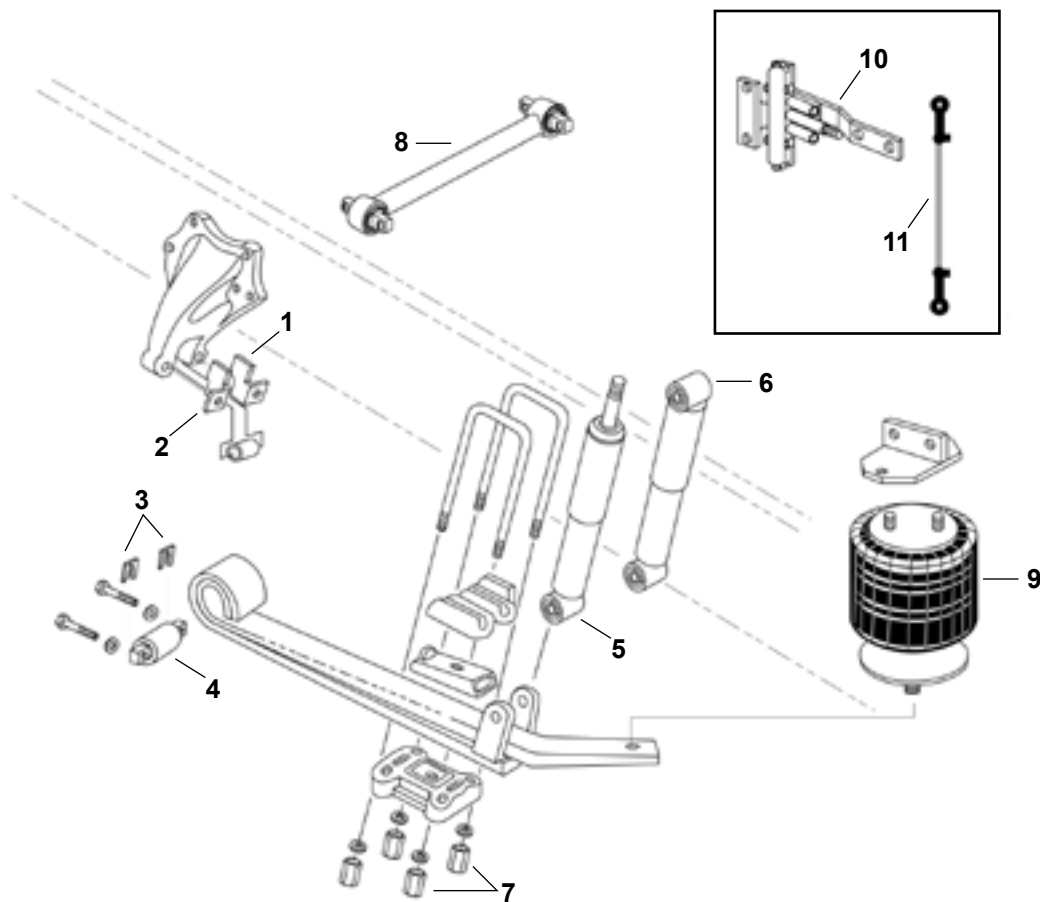

ITEM NUMBER	PART NUMBER	DESCRIPTION
1	E-8803	HANGER WEAR PAD, RIGHT HAND
2	E-8802	HANGER WEAR PAD, LEFT HAND
3	E-8805	ALIGNMENT SHIM, 1/8"
3	E-8806	ALIGNMENT SHIM, 1/16"
4	E-8804	SPRING EYE BUSHING
5	M85319	FLEETLINE SHOCK, FLC112
5	M89428	GAS SLX SHOCK, FLC112
6	M85724	FLEETLINE SHOCK, FLC112
7	E-UB8267-153	U-BOLT ASSEMBLY, SQ BEND, 7/8"-14 THD x 5 3/16" W x 15 3/8" L
8	E-8808	RIGID TORQUE ARM
9	FS9780	AIR SPRING
10	E-4323	HEIGHT CONTROL VALVE
11	E-7852	LEVELING VALVE LINK KIT



# HENDRICKSON INTRAAX AIR SUSPENSION

AA230T / AA250T

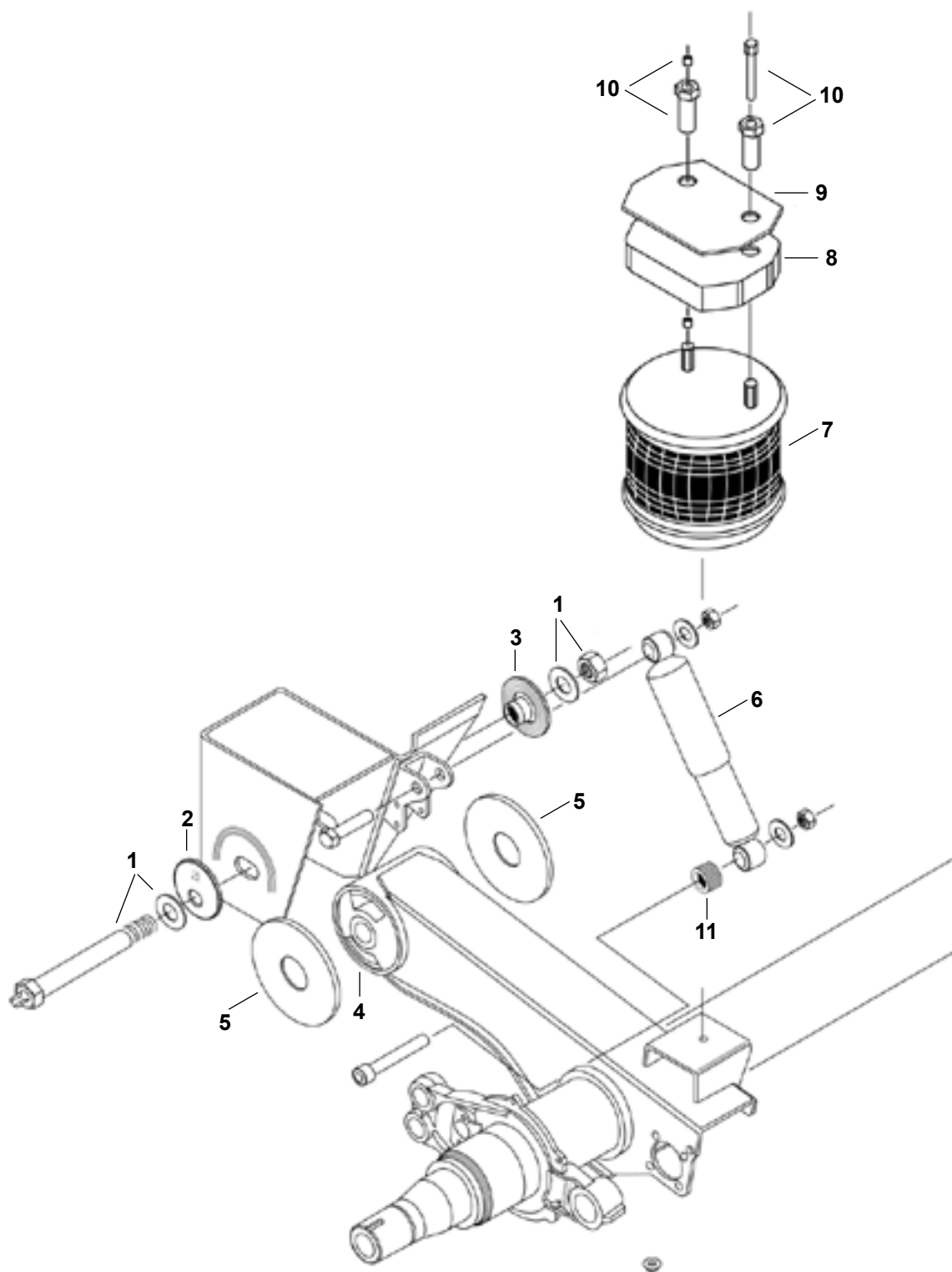

# HENDRICKSON INTRAAX AIR SUSPENSION

AA230T / AA250T

ITEM NUMBER	PART NUMBER	DESCRIPTION
1	E-10730A	PIVOT BOLT KIT. INCLUDE BOLT, NUT AND (2) WASHERS
2	E-10754	OUTBOARD ECCENTRIC ALIGNMENT COLLAR, OFFSET NIPPLE
3	E-10755	INBOARD CONCENTRIC ALIGNMENT COLLAR, NIPPLE IN CENTRE
4	E-10729A	TRI-FUNCTIONAL II BUSHING KIT (INCLUDES ITEM 1,4 & 5)
5	E-6122	WEAR PAD X 2
6	85000	SHOCK ABSORBER, STANDARD (REPLACES HENDRICKSON S-20002)
6	89436	SHOCK ABSORBER, GAS (REPLACES HENDRICKSON S-20002,S-20126)
6	85323	SHOCK ABSORBER, HIGH DAMPING (REPLACES HENDRICKSON S-20126)
7	FS8709	AIR SPRING AA230T
7	FS8091	AIR SPRING AA250T
8	E-14339	AIR SPRING SPACER, 1 1/8" THICK, 15" RIDE HEIGHT
8	E-14340	AIR SPRING SPACER, 1 7/8" THICK, 16" RIDE HEIGHT
8	E-14341	AIR SPRING SPACER, 3 1/8" THICK, 17" RIDE HEIGHT
9	E-14337	AIR SPRING PLATE, BOLT-ON
9	E-14338	AIR SPRING PLATE, WELD-ON
10	E-14342	AIR SPRING FITTING KIT, - NO SPACER 13.5", 14", 18", AND 19" RIDE HEIGHTS
10	E-14343	AIR SPRING FITTING KIT, 1" SPACER, 15" RIDE HEIGHT
10	E-14344	AIR SPRING FITTING KIT, 2" SPACER, 16" RIDE HEIGHT
10	E-14345	AIR SPRING FITTING KIT, 3" SPACER, 17" RIDE HEIGHT
11	E-11831	SPACER



# HENDRICKSON AIR SUSPENSION

## HA SERIES

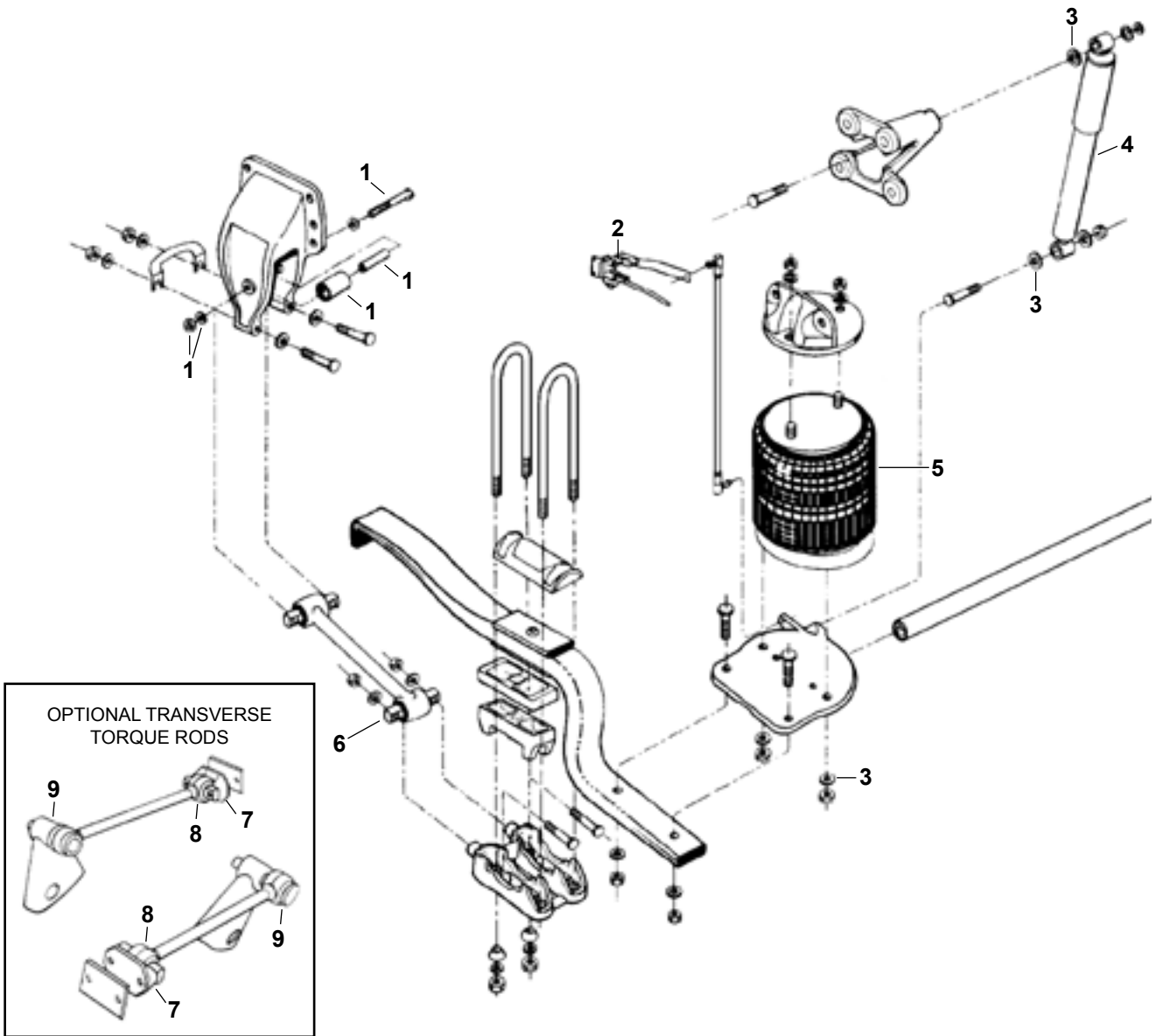

ITEM NUMBER	PART NUMBER	DESCRIPTION
1	E-9432A	REBOUND ROLLER ASSEMBLY
2	E-11494	HEIGHT CONTROL VALVE
3	E-2545	WASHER
4	M85013	SHOCK ABSORBER
4	M83122	SHOCK ABSORBER
4	M89406	SHOCK ABSORBER
4	M83123	SHOCK ABSORBER
4	M89405	SHOCK ABSORBER
5	FS9287	AIR SPRING (HA) 1991-UP
5	FS9466	AIR SPRING (HA) UP TO 1991
6	E-5275	TORQUE ROD BUSHING (SAME AS HENDRICKSON 47691)
7	E-2634	TORQUE ROD FRAME BRACKET
8	R302226	TORQUE ROD BUSH (RUBBER/STEEL) SAME AS HENDRICKSON 44695 OR 44695000L
9	R302228	TORQUE ROD BUSH (RUBBER/STEEL - TAPERED PIN) SAME AS HENDRICKSON 44697 OR 44697000L

# HENDRICKSON AIR SUSPENSION HAS SERIES

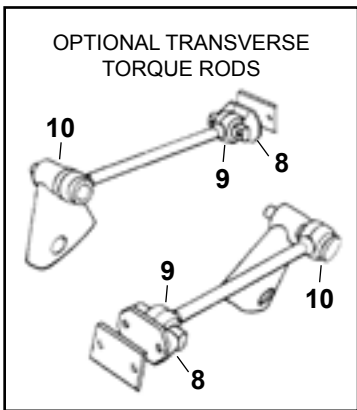
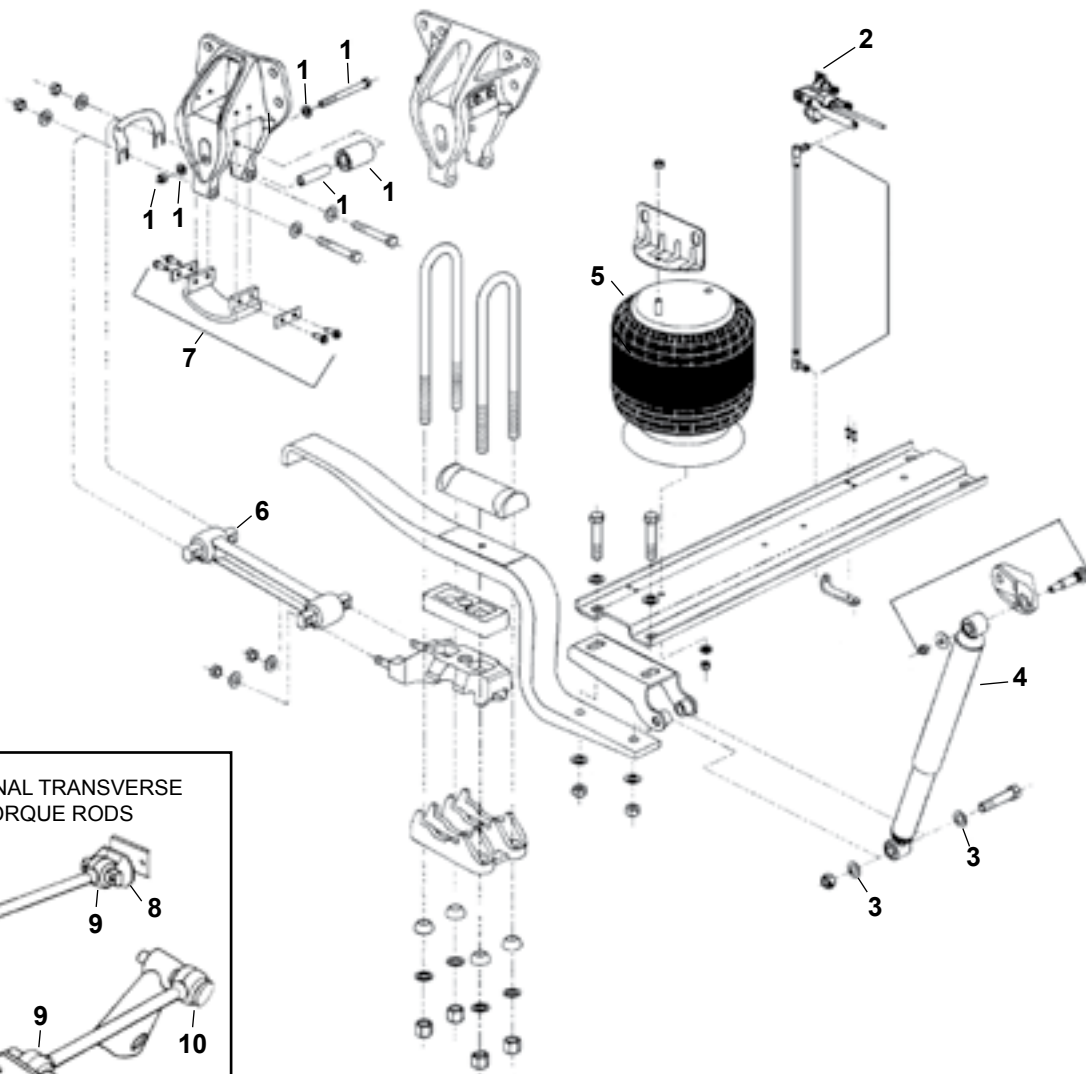

ITEM NUMBER	PART NUMBER	DESCRIPTION
1	E-9432A	REBOUND ROLLER ASSEMBLY
2	E-11494	HEIGHT CONTROL VALVE
3	E-2545	WASHER
4	M85013	SHOCK ABSORBER
4	M83122	SHOCK ABSORBER
4	M89406	SHOCK ABSORBER
4	M83123	SHOCK ABSORBER
4	M89405	SHOCK ABSORBER
5	FS9373	AIR SPRING (HAS)
6	E-5275	TORQUE ROD BUSHING (SAME AS HENDRICKSON 47691)
6	R309395	TORQUE ROD BUSHING ONLY FOR 460
7	E-9391	SLIPPER PAD KIT
8	E-2634	TORQUE ROD FRAME BRACKET
9	R302226	TORQUE ROD BUSH (RUBBER/STEEL) SAME AS HENDRICKSON 44695 OR 44695000L
10	R302228	TORQUE ROD BUSH (RUBBER/STEEL - TAPERED PIN) SAME AS HENDRICKSON 44697 OR 44697000L



# HENDRICKSON AIR SUPENSION

HT190U / HT230 / HT250 SERIES

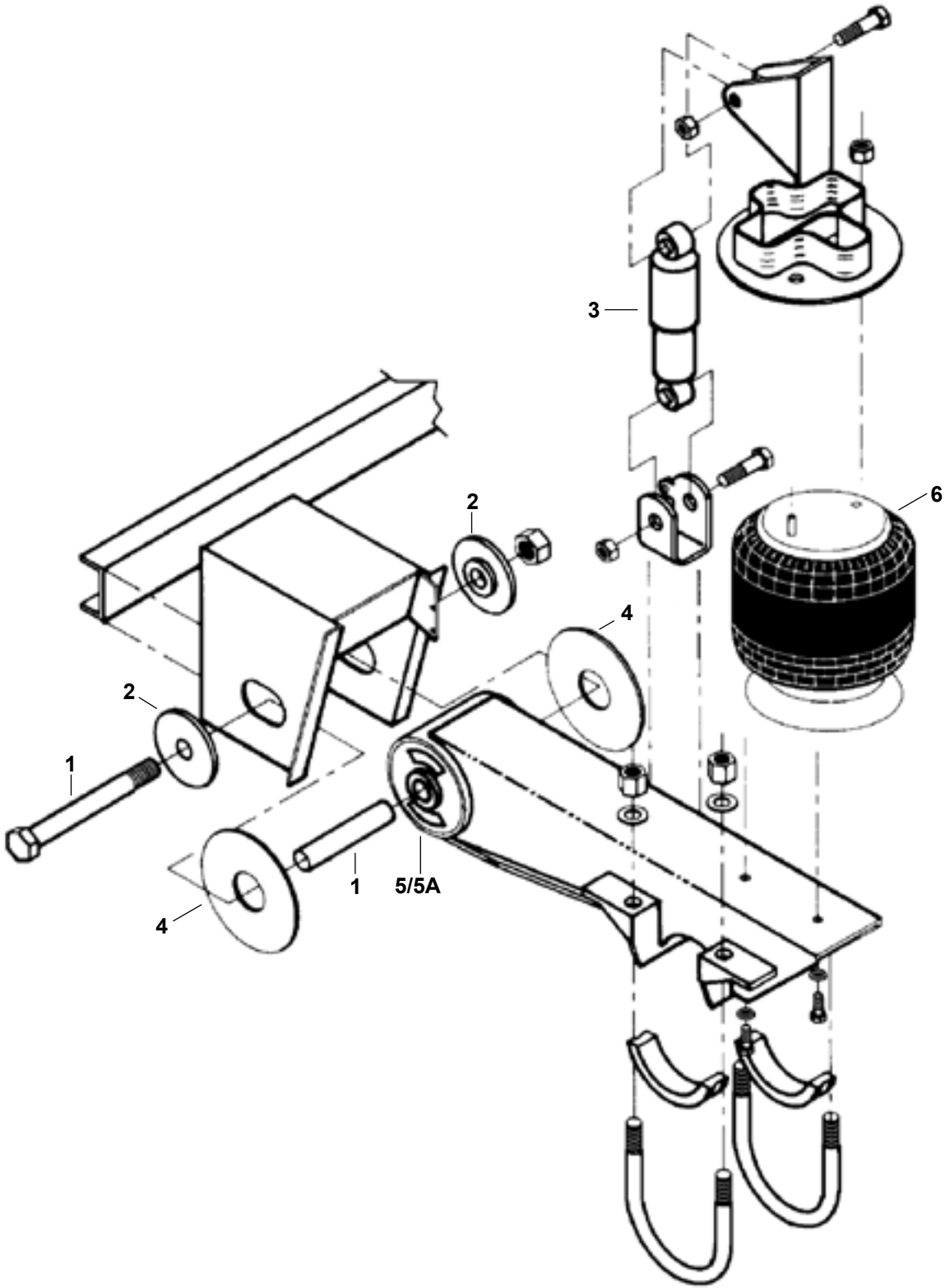



# HENDRICKSON AIR SUSPENSION

HT190U / HT230 / HT250 SERIES

ITEM NUMBER	PART NUMBER	DESCRIPTION
1	E-3768	PIVOT BOLT KIT (BOLT,NUT & SLEEVE)
2	E-3771	ALIGNMENT COLLAR
3	M85000	SHOCK ABSORBER, STANDARD
3	M89436	SHOCK ABSORBER, GAS
4	E-6122	WEAR PAD
5	E-6121	TRI-FUNCTIONAL BUSHING KIT - INCLUDES ITEMS 1,4 & 5
6	FS9270	AIR SPRING , 2 TOP STUDS (HT230)
6	FS9265	AIR SPRING (HT250)
6	FS8944	AIR SPRING (HT190U)



# HENDRICKSON AIR SUSPENSION

T15 / T17 / HT300

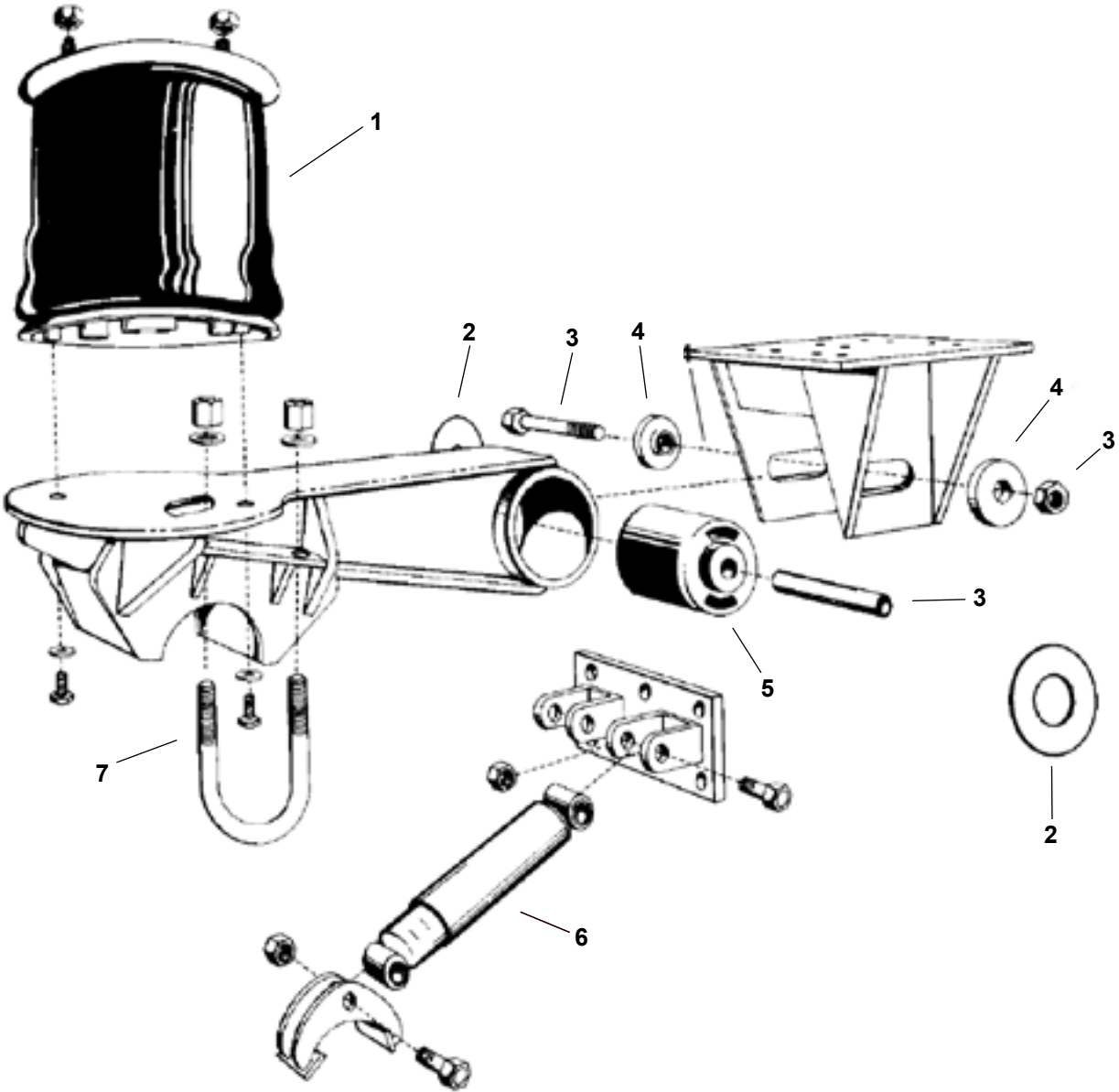

# HENDRICKSON AIR SUSPENSION

T15 / T17 / HT300

ITEM NUMBER	PART NUMBER	DESCRIPTION
1	FS9270	AIR SPRING, 2 TOP STUDS (HT230)
1	FS9265	AIR SPRING (HT250)
1	MLF7112	AIR SPRING (T15,T17)
2	E-6122	WEAR PAD
3	E-3768	PIVOT BOLT KIT
4	E-3771	ALIGNMENT COLLAR
5	E-6121	TRI-FUNCTIONAL BUSHING KIT - INCLUDES ITEMS 2, 3 & 5
6	M85030	SHOCK ABSORBER, STANDARD (T15,T17)
6	M89440	SHOCK ABSORBER, GAS (T15,T17)
6	M85323	SHOCK ABSORBER, STANDARD (HT300)
6	M89436	SHOCK ABSORBER, GAS (HT300)
7	E-UB8165-10	U-BOLT ASSY RD, BEN 7/8"-14 THD.5" WIDE X 10" LONG



# HENDRICKSON AUXILIARY AIR SUSPENSION

HLM -HLM-1 -HLM-1-TR

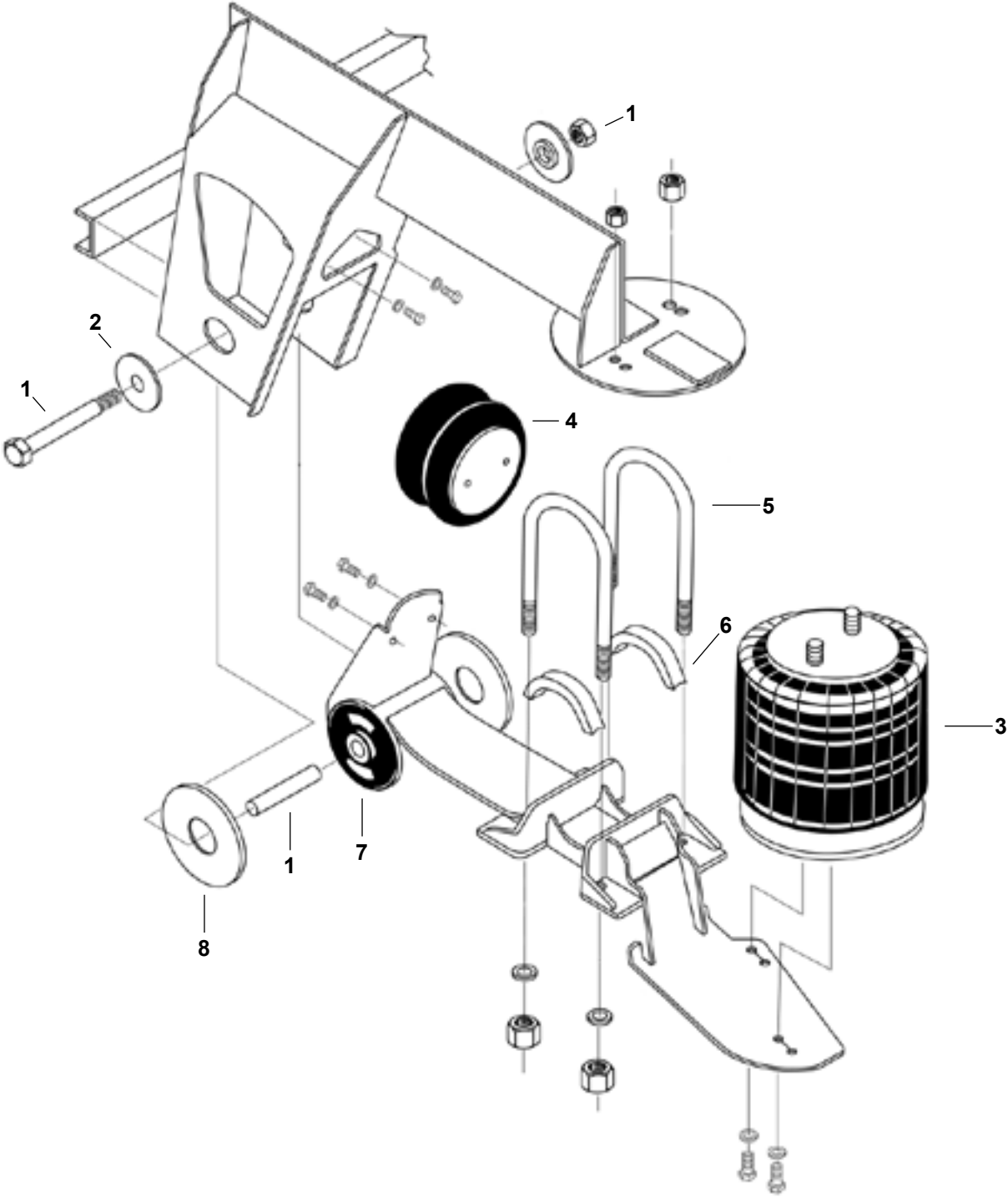

# HENDRICKSON AUXILIARY AIR SUSPENSION

HLM -HLM-1 -HLM-1-TR

ITEM NUMBER	PART NUMBER	DESCRIPTION
1	E-3768	PIVOT BOLT KIT
2	E-3771	ALIGNMENT COLLAR
3	FS9367	AIR SPRING (RIDE)
4	FS6935	AIR SPRING (LIFT)
5	E-UB8168-082	U-BOLT ASSEMBLY, RD. BEND, 7/8"-14 THD. X 6" WIDE X 8 1/4" LONG
6	E-6124	AXLE SPACER
7	E-6121	TRI-FUNCTIONAL BUSHING KIT, INCLUDES KEY NOS. 1, 7, 8
8	E-6122	BUSHING WEAR PAD



# MERITOR CS9i TOP/LOW MOUNT AIR SUSPENSION

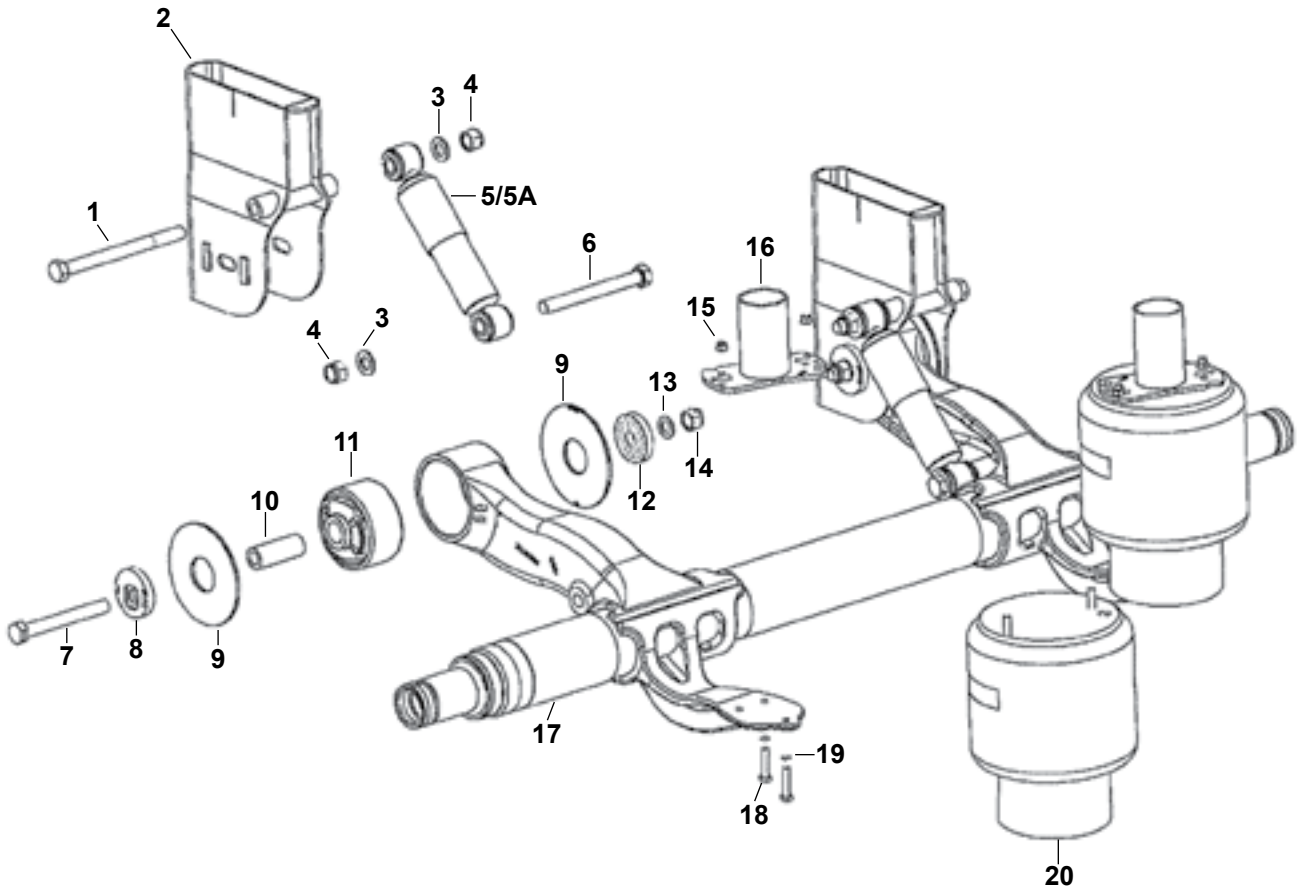

LOW AXLE

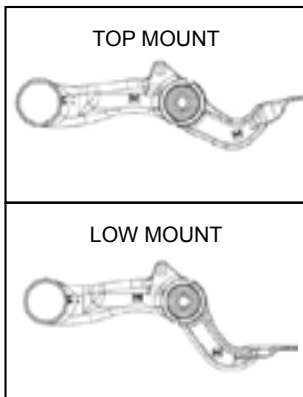
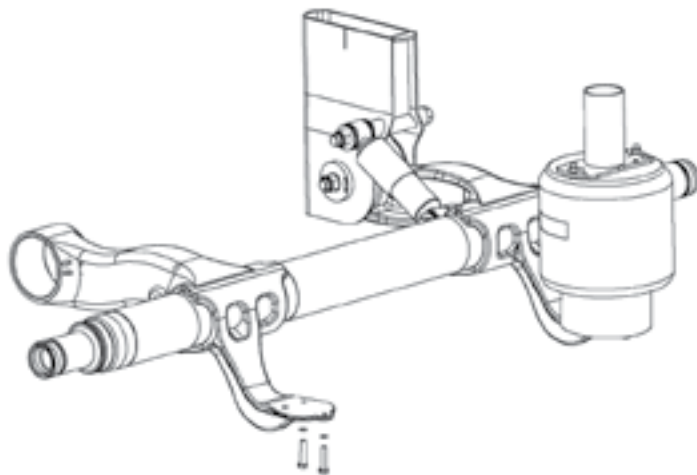

# MERITOR CS9i TOP/LOW MOUNT AIR SUSPENSION

ITEM NUMBER	PART NUMBER	DESCRIPTION
1	21228171PK4	BOLT (M24 X 280MM)
2	SEE TABLE	FRAME BRACKET
3*	21222923PK50	WASHER (HARD M24)
4*	99527004PK50	NUT (SELF LOCK M24 X 3.0)
5	21228930	SHOCK ABSORBER - TOP MOUNT
5A	21228392	SHOCK ABSORBER - LOW MOUNT
6	21216189PK4	BOLT (M24 X 225MM)
7*	21222230PK10	BOLT (M24 X 195MM)
8	21228664	TRACKING BOSS - ECCENTRIC
9*	21226663PK12	WEAR WASHER
10	-	PIVOT BUSH SLEEVE
11*	21230041	PIVOT BUSH ASSEMBLY
12	21228663	TRACKING BOSS - CONCENTRIC
13	21222923PK50	WASHER (HARD M24)
14	99527004PK50	NUT (SELF LOCK M24 X 3.0)
15	99544001PK10	NUT (FLANGED SELF LOCK M12)
16	SEE TABLE BELOW	AIR SPRING PEDESTAL
17	-	AXLE ASSEMBLY
18	99526002PK50	SCREW (HEX M12 X 55MM)
19	99510003PK20	WASHER (SPRING LOCK M12)
20	21229214	AIR SPRING
21	SUS10A	PIVOT BUSH KIT**

RIDE HEIGHT		FRAME BRACKET (LH)	FRAME BRACKET (RH)	AIR
LOW	TOP	PART NUMBER	PART NUMBER	SPRING PEDESTAL
200	325	21228876	21228877	21229119
225	350	21229385	21229386	21229120
250	375	21228878	21228879	21229121
275	400	21229387	21229388	21229122
300	425	21228880	21228881	21229123
325	450	21229389	21229390	21229124
350	475	21228882	21228883	21229125
375	500	21229391	21229392	21229126

**NOTE:**

Refer to \* symbol for kit inclusions

\*\* Please be advised that 2 kits are require to complete 1 axle assembly



# MERITOR ROR FLEXAIR SUSPENSION

FL9000

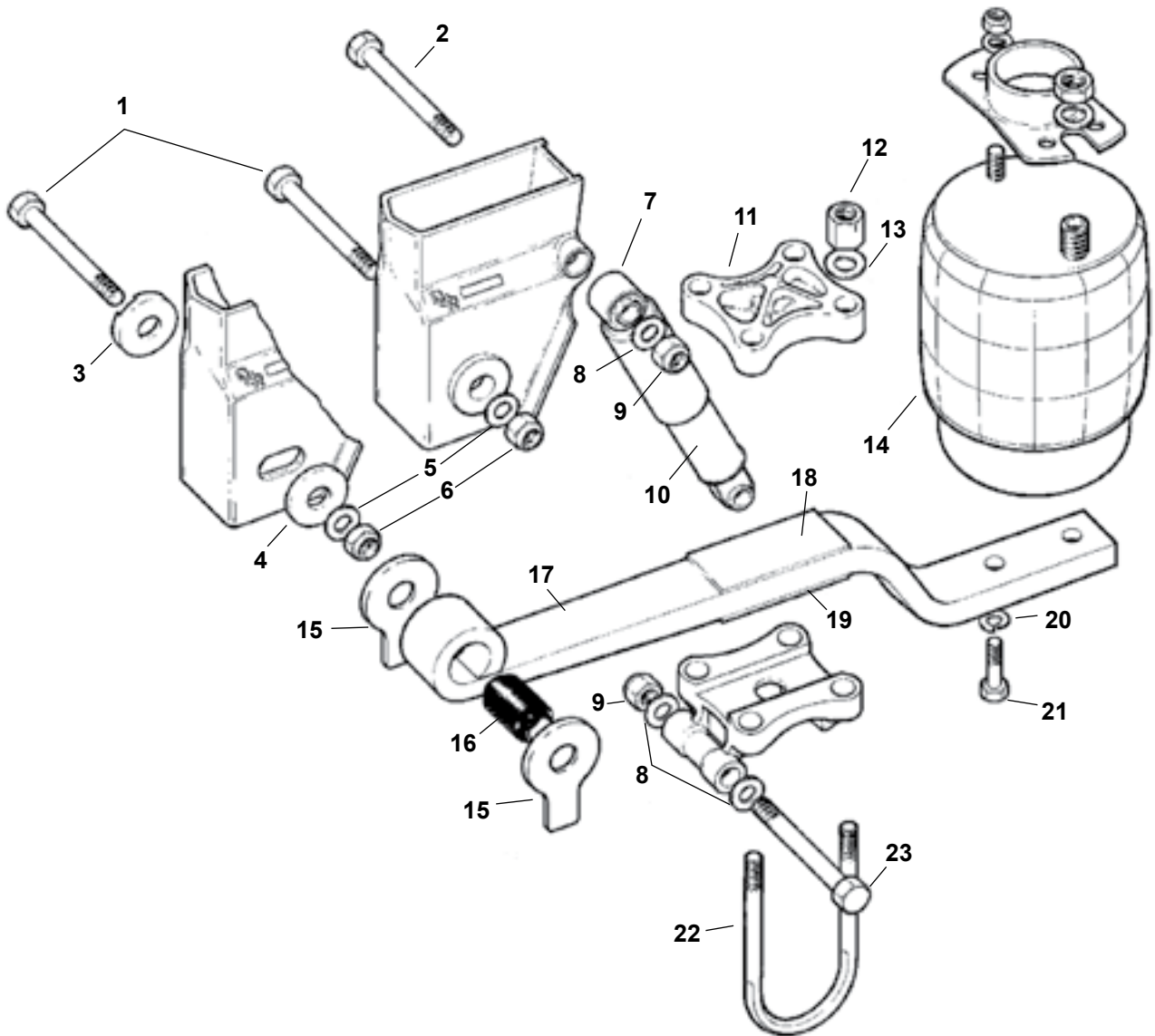



# MERITOR ROR FLEXAIR SUSPENSION

FL9000

ITEM NUMBER	PART NUMBER	DESCRIPTION
1	21222234	PIVO BOLT,M30 X 200
1	21222230PK10	PIVO BOLT,M24 X 195
2	21222231PK10	BOLT M24X250
3	21222221	TRACKING BUSH, ECCENTRIC, M30
3	21228663	TRACKING BUSH, ECCENTRIC, M24
4	21222287	TRACKING BUSH, CONCENTRIC, M30
4	21228664	TRACKING BUSH, CONCENTRIC, M24
5	99513008	PIVO WASHER, M30
5	99513007	PIVO WASHER, M24
6	99527003	PIVO NUT, M30
6	99527004PK50	PIVO NUT, M24
7	DBK2	BUSH SHOCK ABSORBER
8	99513007	SHOCK ABSORBER WASHER, M24
9	99527004PK50	SHOCK ABSORBER NUT, M24
10	21224745	SHOCK ABSORBER
11	21222395	U BOLT PLATE
12	21222243	U BOLT NUT, M24
13	21222923PK50	U BOLT WASHER, M24
14	21222442	AIR SPRING
15	21222690	WEAR PLATE, UNTRACKED, M30
15	21224386	WEAR PLATE, TRACKED, M24
16	21222609	PIVOT BUSH, M30
16	21224663	PIVOT BUSH, M24
17	21222247	TRAILING ARM ASSEMBLY, C/W BUSH, M30
17	21224664	TRAILING ARM ASSEMBLY, C/W BUSH, M24
18	21222330	SPACER PLATE TOP 3MM
19	21222329	SHIM
20	99510003PK20	SPRING WASHER M12
21	99526002PK50	BOLT M12 X 55
22	21223928	U BOLT, M24 X 280
23	21222231PK10	BOLT M24X250



# MERITOR ROR FLEXAIR SUSPENSION

FL9000L

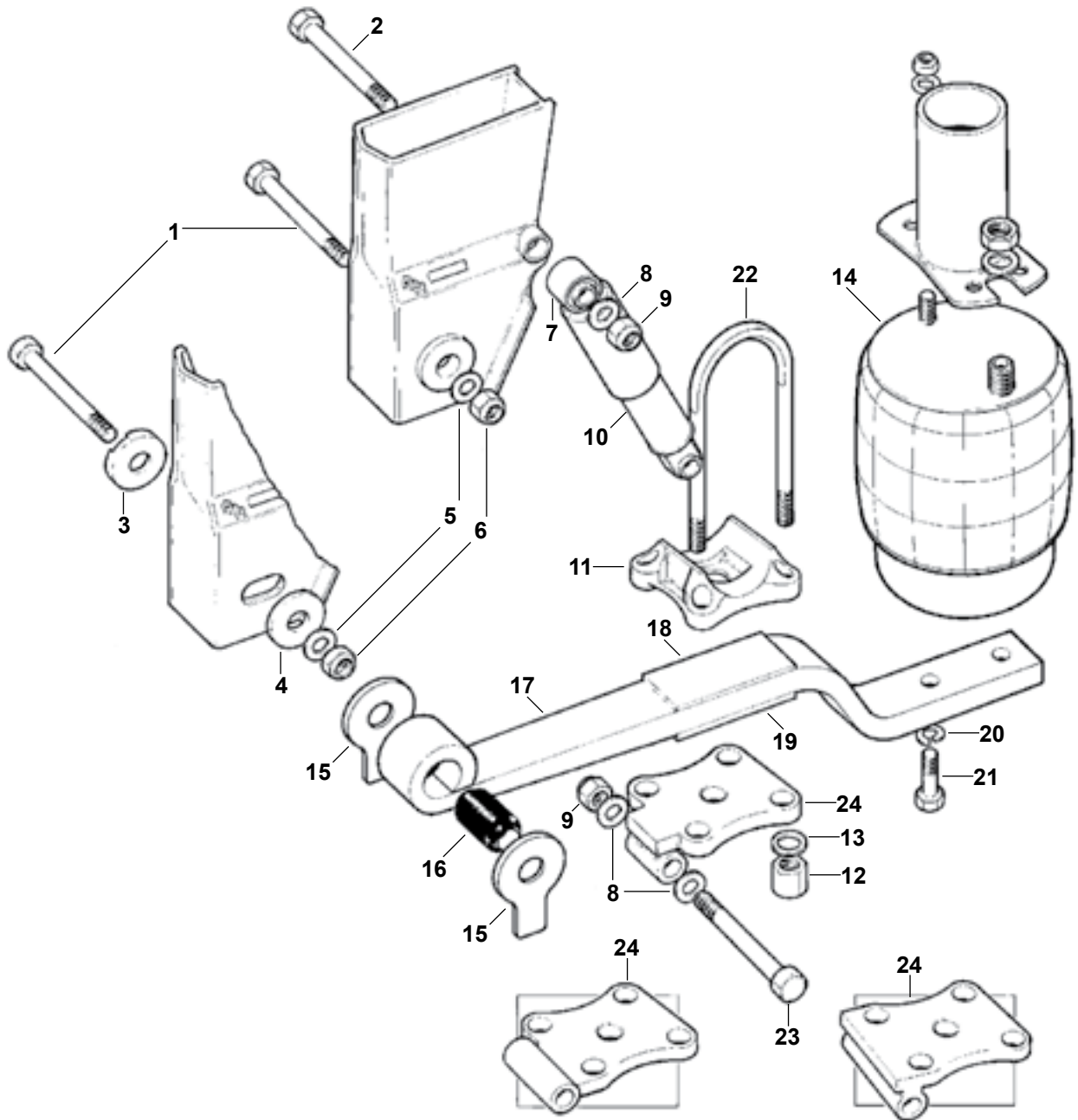

# MERITOR ROR FLEXAIR SUSPENSION

FL9000L

ITEM NUMBER	PART NUMBER	DESCRIPTION
1	21222234	PIVO BOLT,M30 X 200
1	21222230PK10	PIVO BOLT,M24 X 195
2	21222231PK10	SHOCK ABSORBER - TOP, M24 X 250
3	21222221	TRACKING BUSH, ECCENTRIC, M30
3	21228663	TRACKING BUSH, ECCENTRIC, M24
4	21222287	TRACKING BUSH, CONCENTRIC, M30
4	21228664	TRACKING BUSH, CONCENTRIC, M24
5	99513008	PIVO WASHER, M30
5	99513007	PIVO WASHER, M24
6	99527003	PIVO NUT, M30
6	99527004PK50	PIVO NUT, M24
7	DBK2	BUSH SHOCK ABSORBER
8	99513007	SHOCK ABSORBER WASHER, M24
9	99527004PK50	SHOCK ABSORBER NUT, M24
10	21224745	SHOCK ABSORBER
11	21222262	SPRING SEAT
12	21222243	U BOLT NUT, M24
13	21222923PK50	U BOLT WASHER, M24
14	21222442	AIR SPRING
15	21222690	WEAR PLATE, UNTRACKED, M30
15	21224386	WEAR PLATE, TRACKED, M24
16	21222609	PIVOT BUSH, M30
16	21224663	PIVOT BUSH, M24
17	21222247	TRAILING ARM ASSEMBLY, C/W BUSH, M30
17	21224664	TRAILING ARM ASSEMBLY, C/W BUSH, M24
18	-	SHIM
19	21222329	SHIM
20	99510003PK20	SPRING WASHER M12
21	99526002PK50	BOLT M12 X 55
22	21223928	U BOLT, M24 X 280
23	21222231PK10	BOLT M24X250
24	21223646L	U BOLT PLATE L/H
24	21223646R	U BOLT PLATE R/H



# MERITOR ROR FLEXAIR SUSPENSION

FL9000M

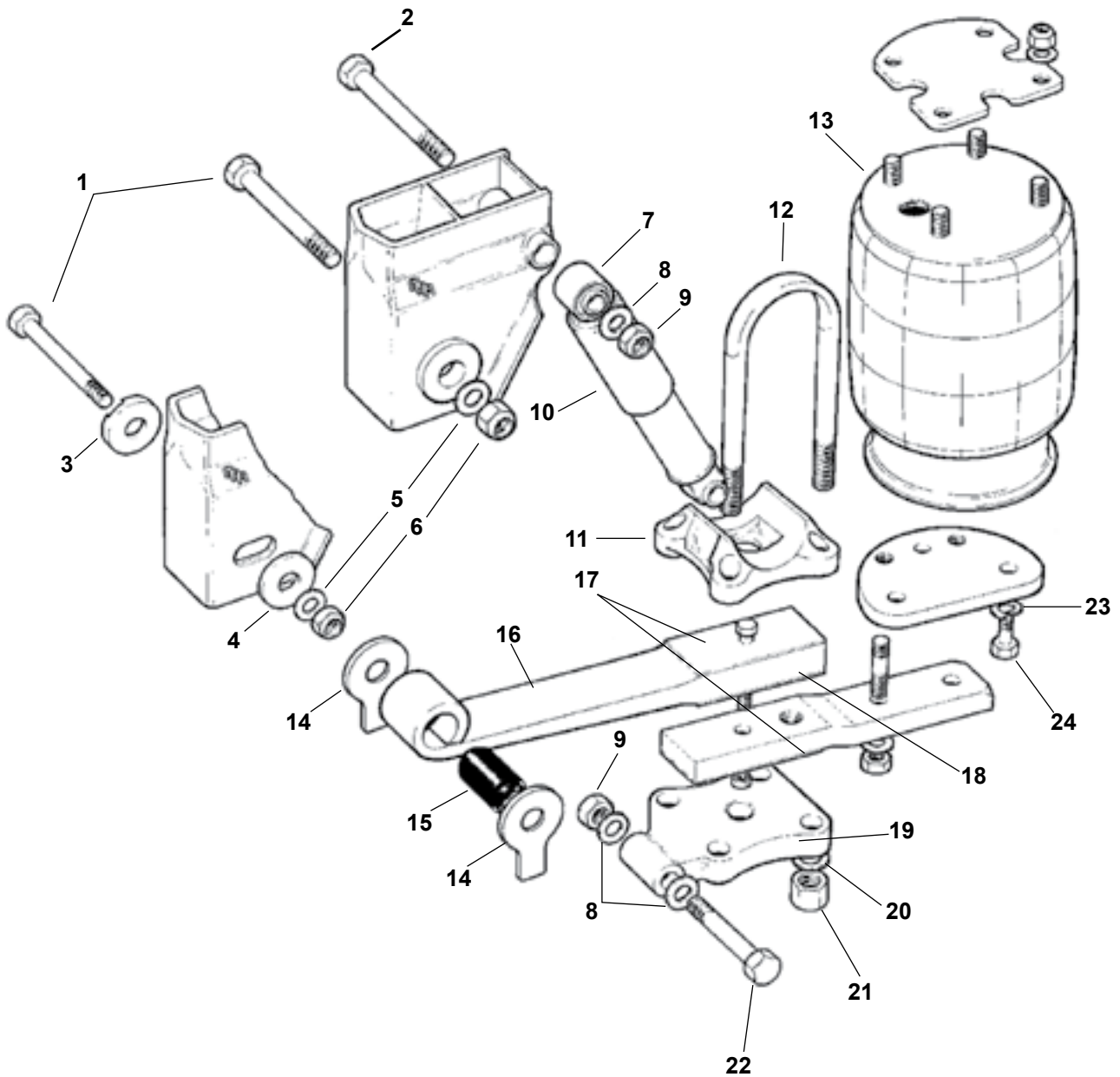

# MERITOR ROR FLEXAIR SUSPENSION

FL9000M

ITEM NUMBER	PART NUMBER	DESCRIPTION
1	21222234	PIVO BOLT,M30 X 200
1	21222230PK10	PIVO BOLT,M24 X 195
2	21222231PK10	BOLT M24X250
3	21222221	TRACKING BUSH, ECCENTRIC, M30
3	21228663	TRACKING BUSH, ECCENTRIC, M24
4	21222287	TRACKING BUSH, CONCENTRIC, M30
4	21228664	TRACKING BUSH, CONCENTRIC, M24
5	99513008	PIVO WASHER, M30
5	99513007	PIVO WASHER, M24
6	99527003	PIVO NUT, M30
6	99527004PK50	PIVO NUT, M24
7	DBK1	BUSH SHOCK ABSORBER
8	99513007	SHOCK ABSORBER WASHER, M24
9	99527004PK50	SHOCK ABSORBER NUT, M24
10	50108	SHOCK ABSORBER
11	21222262	SPRING SEAT
12	21222326	U BOLT, M24 X 280
13	21222673	AIR SPRING
14	21224386	WEAR PLATE, TRACKED, M24
14	21222690	WEAR PLATE, UNTRACKED, M30
15	21222609	PIVOT BUSH, M30
15	21224663	PIVOT BUSH, M24
16	21224465	TRAILING ARM ASSEMBLY, C/W BUSH, M30
16	-	TRAILING ARM ASSEMBLY, C/W BUSH, M24
17	-	SHIM
18	21222198	SHIM
19	-	U BOLT PLATE
20	21222923PK50	U BOLT WASHER, M24
21	21222243	U BOLT NUT, M24
22	21222230PK10	SHOCK ABSORBER - BOTTOM, M24 X 195
23	99510003PK20	SPRING WASHER M12
24	99526000	BOLT M12 X 55



# MERITOR ROR FLEXAIR SUSPENSION

FL 11000 / FL 11000L

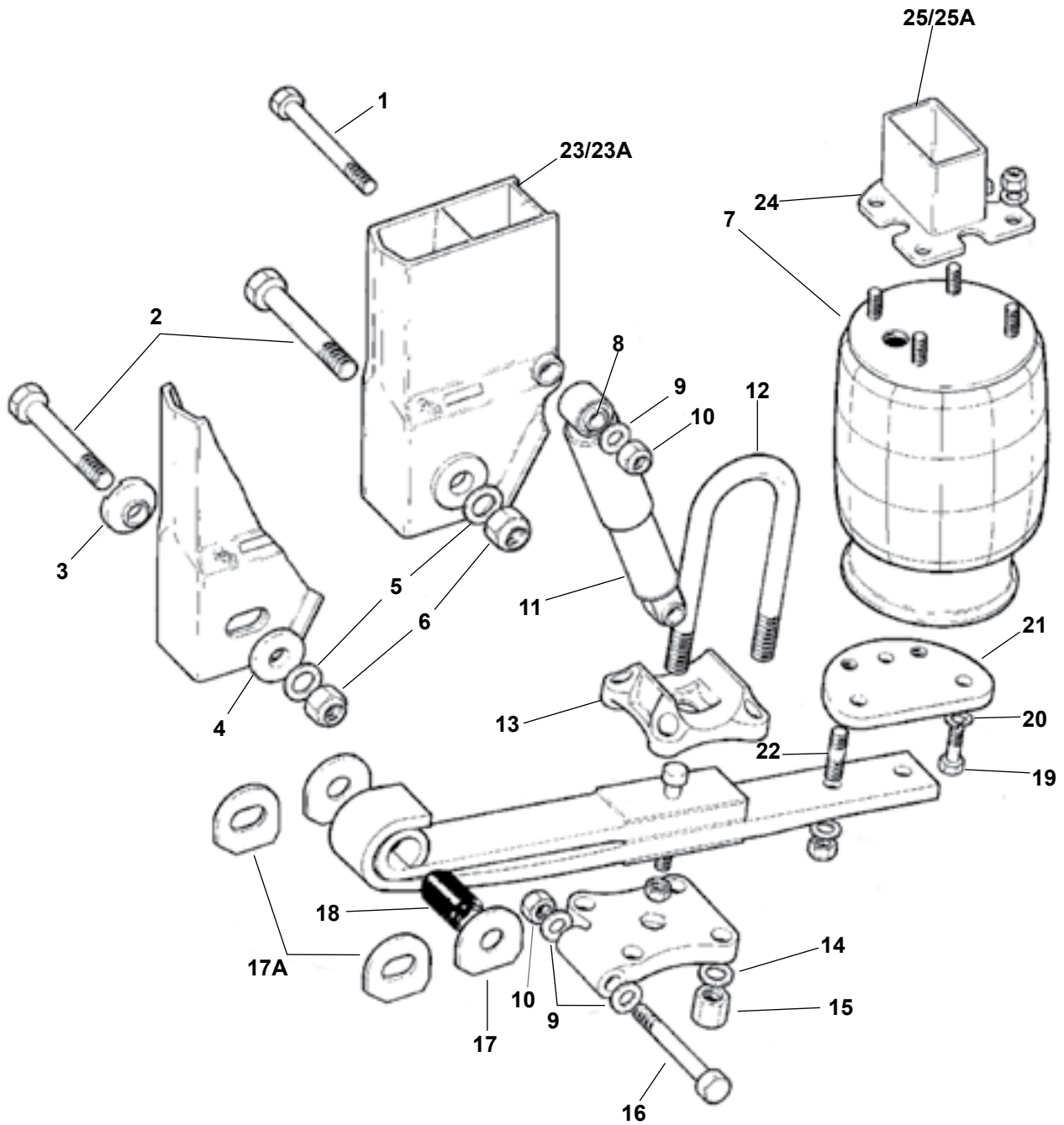

# MERITOR ROR FLEXAIR SUSPENSION

FL 11000 / FL 11000L

ITEM NUMBER	PART NUMBER	DESCRIPTION
1	21222231PK10	SHOCK ABSORBER - TOP, M24 X 250
2	21222234	PIVO BOLT, M30 X 200
3	21222221	TRACKING BUSH, ECCENTRIC, M30
4	21222287	TRACKING BUSH, CONCENTRIC, M30
5	99513008	PIVO WASHER, M30
6	99527003	PIVO NUT, M30
7	21222239FS	AIR SPRING, FL11000
7	21208082	AIR SPRING, FL11000L
8	DBK1	BUSH SHOCK ABSORBER
9	99513007	SHOCK ABSORBER WASHER, M24
10	-	SHOCK ABSORBER NUT, M24
11	21224745	SHOCK ABSORBER
12	21222326	U BOLT, M24 X 315
13	21222262	SPRING SEAT NO DAMPER LU
14	21222923PK50	U BOLT WASHER, M24
15	21222243	U BOLT NUT, M24
16	21222230PK10	SHOCK ABSORBER - BOTTOM, M24 X 195
17	21222690	WEAR PLATE, UNTRACKED, M30
17A	21222223	WEAR PLATE, TRACKED, M30
18	21222609	PIVOT BUSH, M30
19	99526000	BOLT AIR SPRING
20	99510003PK20	SPRING WASHER M12
21	21222248	A/SPG FIX PLATE 95 O/SET FLEXAIR 11000
22	21222255	STUD RR AXLE
23	21222714	FRAME MOUNTING BRACKET L&R 280MM HIGH 11000L
23A	21222716	FRAME MOUNTING BRACKET UNTRACKED 11000
24	21222452	AIRSPRING PEDESTAL PLATE
25	21221994	AIRBAG PEDESTAL ASM (275-475 HEIGHT)
25A	21221995	AIR SPRING PED ASSY



# NEWAY ARDST/ARDSTM & L SERIES

MODELS -123-6, -244-6, -246-6

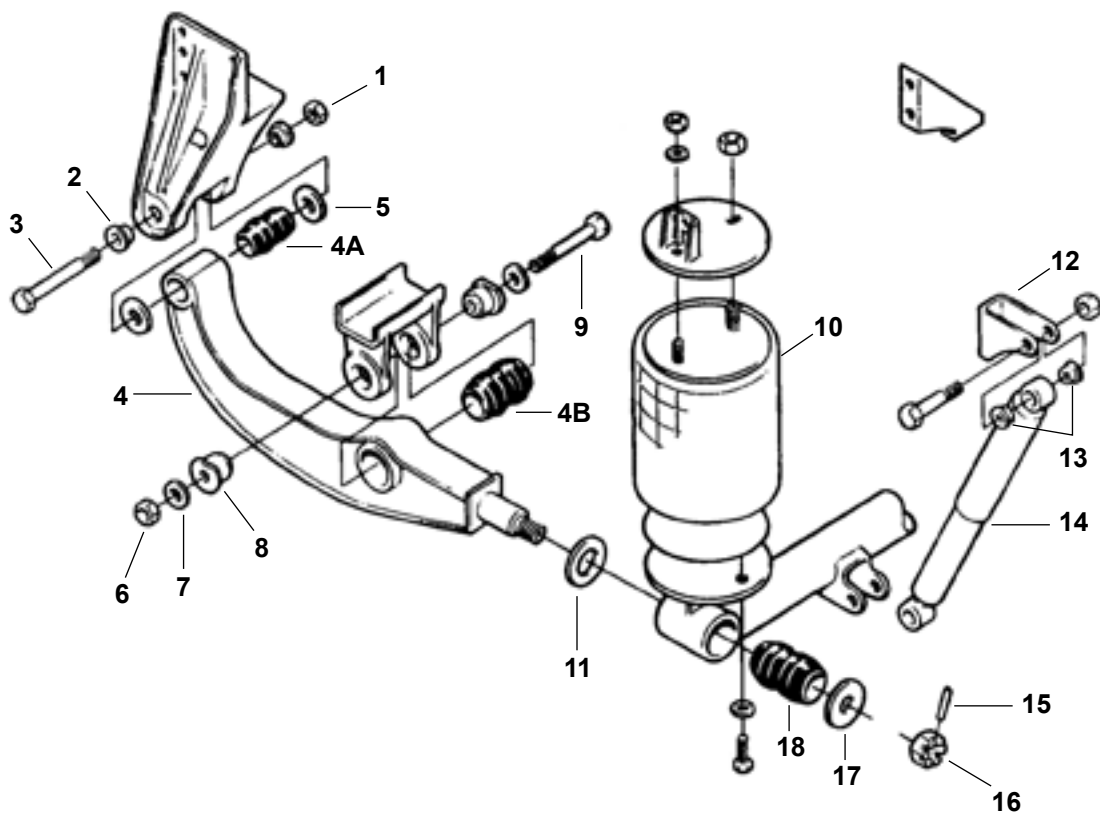



# NEWAY ARDST/ARDSTM & L SERIES

MODELS -123-6, -244-6, -246-6

ITEM NUMBER	PART NUMBER	DESCRIPTION
1	E-4358	LOCK NUT, 1 1/8"-7 THD.
2	E-4267	ALIGNMENT BLOCK
3	E-4364	ROD BOLT, 1 1/8"-7 THD.
4	E-10686	EQUALIZING BEAM ASSEMBLY
4A	E-9292	BUSHING (FRONT END)
4B	E-4253	BUSHING (BEAM CENTER)
5	-	SPACER WASHER (NOT SOLD SEPARATELY - PART OF KIT E-9300A)
6	-	LOCK NUT, 3/4"-10 THD (NOT SOLD SEPARATELY - PART OF KIT E-4387)
7	E-2545	PLAIN WASHER, 3/4"
8	-	ADAPTER BUSHING (NOT SOLD SEPARATELY - PART OF KIT E-4387)
9	-	CAP SCREW, 3/4"-10 THD. X 7 1/2" (NOT SOLD SEPARATELY - PART OF KIT E-4387)
10	FS9121	AIR SPRING
10	FS9082	AIR SPRING
11	-	WASHER (NOT SOLD SEPARATELY - PART OF KIT E-9301)
12	E-4343	SHOCK ABSORBER MOUNTING BRACKET
13	E-4403	SHOCK ABSORBER BUSHING
14	M83209	SHOCK ABSORBER
14	M89414	SHOCK ABSORBER
15	-	ROLL PIN, 3/8" DIAMETER X 3 1/2" LONG (NOT SOLD SEPARATELY - PART OF KIT E-9301)
16	-	HEX SLOTTED NUT, 2 1/4"-12 THD (NOT SOLD SEPARATELY - PART OF KIT E-9301)
17	-	SPACER WASHER (NOT SOLD SEPARATELY - PART OF KIT E-9301)
18	E-9293	TRANSVERSE BEAM BUSHING
KIT	E-9300A	PIVOT CONNECTION KIT, INCLUDES 1, 2, 3, 4A & 5
KIT	E-4387	AXLE PIVOT CONNECTION KIT, INCLUDES 4B, 6, 7, 8 & 9
KIT	E-9301	TRANSVERSE CONNECTION KIT, INCLUDES 11, 15, 16, 17 & 18



# NEWAY SUSPENSION

AD-123/246 -6.5, -8.75, -10 SERIES

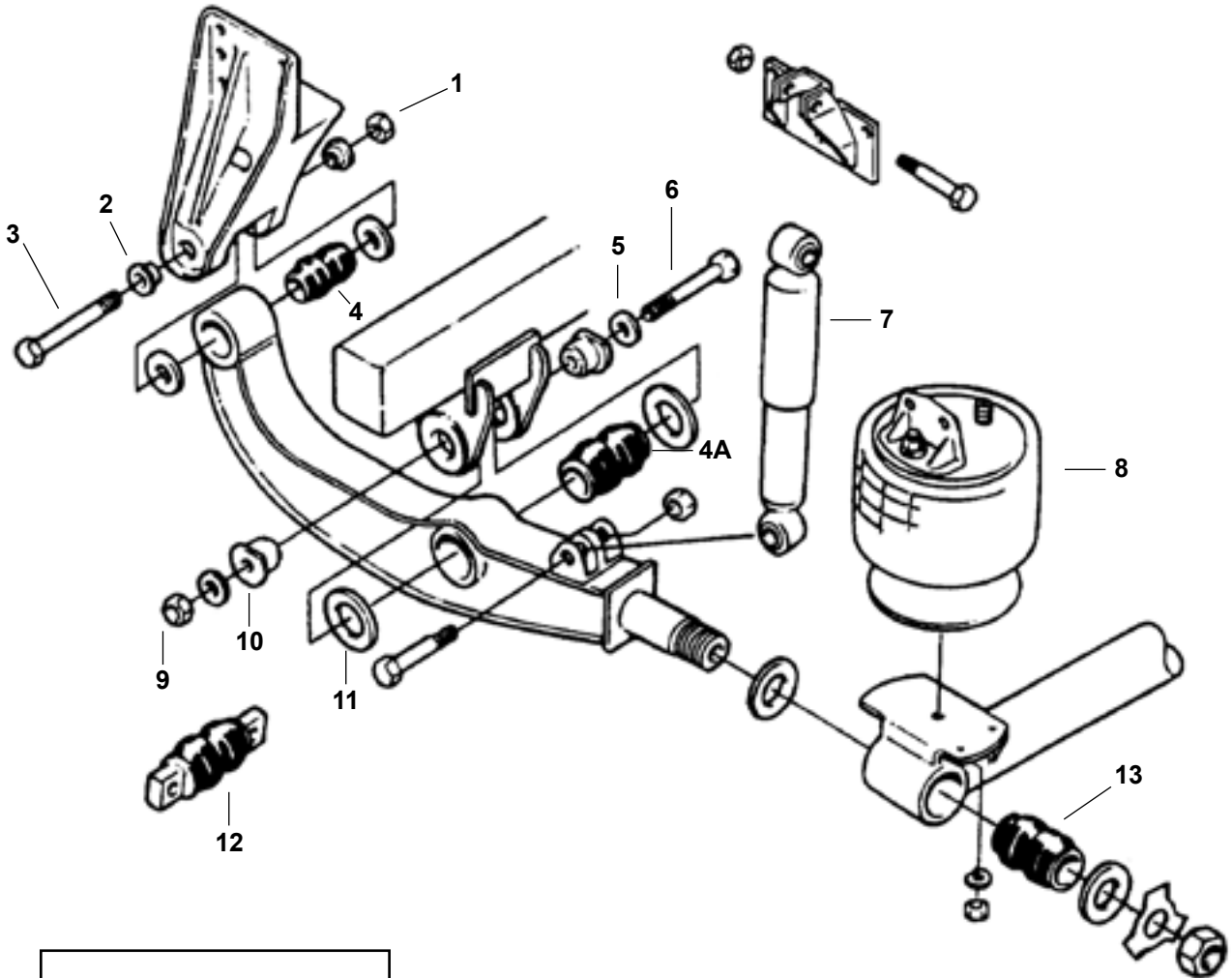

OPTIONAL BAR PIN STYLE  
BEAM CENTER BUSHING

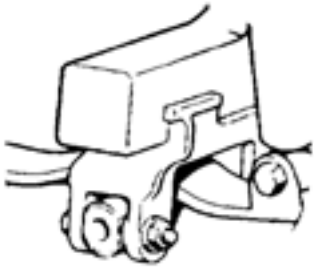

# NEWAY SUSPENSION

AD-123/246 -6.5, -8.75, -10 SERIES

ITEM NUMBER	PART NUMBER	DESCRIPTION
1	E-4358	LOCK NUT
2	E-4267	ALIGNMENT BLOCK
3	E-4364	BOLT
4	E-9292	BEAM BUSHING
4A	E-4253 (RUBBER)	BEAM CENTER BUSHING
4A	E-8681 (POLY)	BEAM CENTER BUSHING
5	-	PLAIN WASHER (NOT SOLD SEPARATELY - PART OF KIT E-4387)
6	-	BOLT (NOT SOLD SEPARATELY - PART OF KIT E-4387)
7	M85906	SHOCK ABSORBER
7	M85909	SHOCK ABSORBER (OPTIONAL, 24 1/4" EXTENDED LENGTH)
8	FS9471	AIR SPRING ASSEMBLY 8.75, INCLUDES MOUNTING BRACKET
8	FS9472	AIR SPRING ASSEMBLY 6.5 & 8.75, INCLUDES MOUNTING BRACKET
9	E-4347	LOCK NUT, 3/4"-10 THD.
10	-	ADAPTER BUSHING (NOT SOLD SEPARATELY - PART OF KIT E-2374)
11	E-4315	BEAM ADAPTER
12	E-10678	BAR PIN CENTER BEAM BUSHING
13	E-4252	TRANSVERSE BEAM BUSHING
KIT	E-4387	BEAM BUSHING KIT, INCLUDES KEY NOS. 4A, 5 & 6, 9 & 10



# FRUEHAUF 'F' TYPE OVERSLUNG

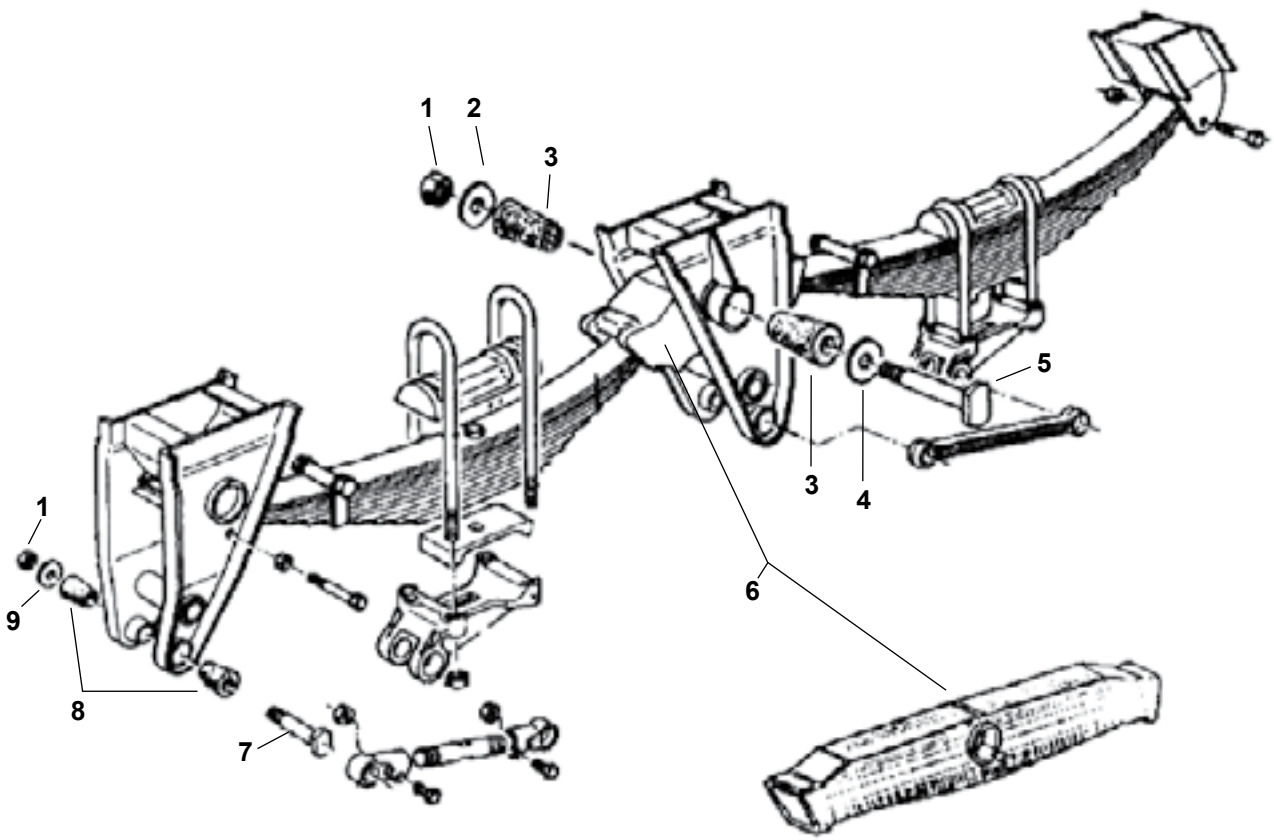

# FRUEHAUF 'F' TYPE OVERSLUNG

ITEM NUMBER	PART NUMBER	DESCRIPTION
1	E-937	NUT
2	E-2832	WASHER
3	E-1020	EQUALISER BUSH (RUBBER)
3	E-7432	EQUALISER BUSH (POLY)
4	E-1021	WASHER
5	E-1019	EQUALISER BOLT
6	E-2830	EQUALISER (8'1")
7	E-1018	BOLT
8	E-927	TORQUE ARM BUSH (RUBBER)
8	E-7433	TORQUE ARM BUSH (POLY)
9	E-1074	WASHER

KIT	E-1024	EQUALISER BUSH ASSY (RUBBER), INCLUDES KEY NOS. 1, 2, 3 & 5
KIT	E-9361	EQUALISER BUSH ASSY (POLY), INCLUDES KEY NOS. 1, 2, 3 & 5
KIT	E-1023	TORQUE ROD BOLT & BUSH ASSY (RUBBER), INCLUDES KEY NOS. 1, 7, 8 & 9
KIT	E-9362	TORQUE ROD BOLT & BUSH ASSY (POLY), INCLUDES KEY NOS. 1, 7,8 & 9



# FRUEHAUF F-2 SUSPENSION

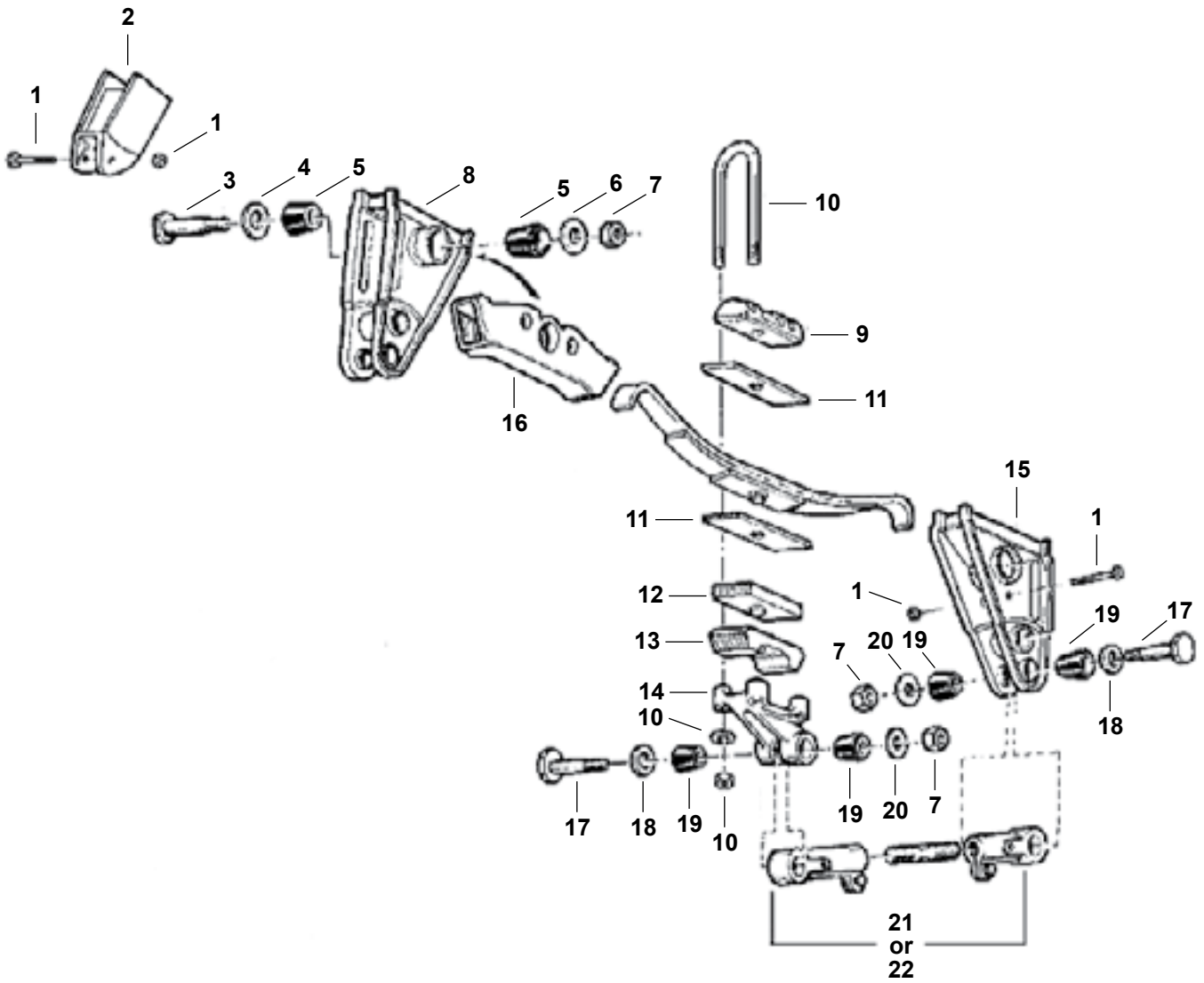

# FRUEHAUF F-2 SUSPENSION

ITEM NUMBER	PART NUMBER	DESCRIPTION
1	E-2829	SPACER ASSEMBLY
2	E-2828	HANGER REAR
3	E-1019	EQUALIZER BOLT (SOLID)
4	E-2832	WASHER OUTER
5	E-1020	EQUALIZER BUSHING (RUBBER)
5	E-7432	EQUALIZER BUSHING (POLY)
6	E-1021	WASHER COMPRESSION
7	E-937	NUT LOCK
8	E-2827	EQUALISER HANGER
9	E-2839	SADDLE SPRING (SINGLE LEAF SPRINGS)
9	E-2840	SADDLE SPRING (MULTI-LEAF SPRINGS)
10	E-UB8161-10	U-BOLT ASSEMBLY, RD. BEND, 7/8"-14 THD. X 3" WIDE X 10" LONG
10	E-UB8161-12	U-BOLT ASSEMBLY, RD. BEND, 7/8"-14 THD. X 3" WIDE X 12" LONG
10	E-UB8161-16	U-BOLT ASSEMBLY, RD. BEND, 7/8"-14 THD. X 3" WIDE X 16" LONG
10	E-UB8161-18	U-BOLT ASSEMBLY, RD. BEND, 7/8"-14 THD. X 3" WIDE X 18" LONG
11	E-2842	LINER DELRIN BOTTOM PAD
12	E-2838	SPACER SPRING
13	E-2837	SPACER SPRING
14	E-2836	BRACKET AXLE
15	E-2826	HANGER FRONT
16	E-2830	EQUALIZER (CAST STEEL)
16	E-2831	EQUALIZER (FABRICATED STEEL)
16	E-8931	EQUALIZER (DUCTILE IRON REPLACES FABRICATED STEEL VERSION)
16	E-9366	EQUALIZER
17	E-1018	BOLT
18	E-2833	WASHER
19	E-927	BUSHING TORQUE ARM (RUBBER)
19	E-7433	BUSHING (POLY)
20	E-1074	WASHER
21	E-2515	TORQUE ROD ASSY
22	E-2514	TORQUE ROD NO BUSH

KIT	E-1024	EQUALISER BUSHING ASSY (RUBBER) - INCLUDES KEY Nos 3, 4, 5, 6 & 7
KIT	E-9361	EQUALISER BUSHING ASSY (POLY) - INCLUDES KEY Nos 3, 4, 5, 6 & 7
KIT	E-1023	TORQUE ROD BOLT & BUSH ASSY - INCLUDES KEY Nos 7, 17, 18, 19 & 20
KIT	E-9362	TORQUE ROD BOLT & BUSH ASSY - INCLUDES KEY Nos 7, 17, 18, 19 & 20

# HENDRICKSON HN-402/462

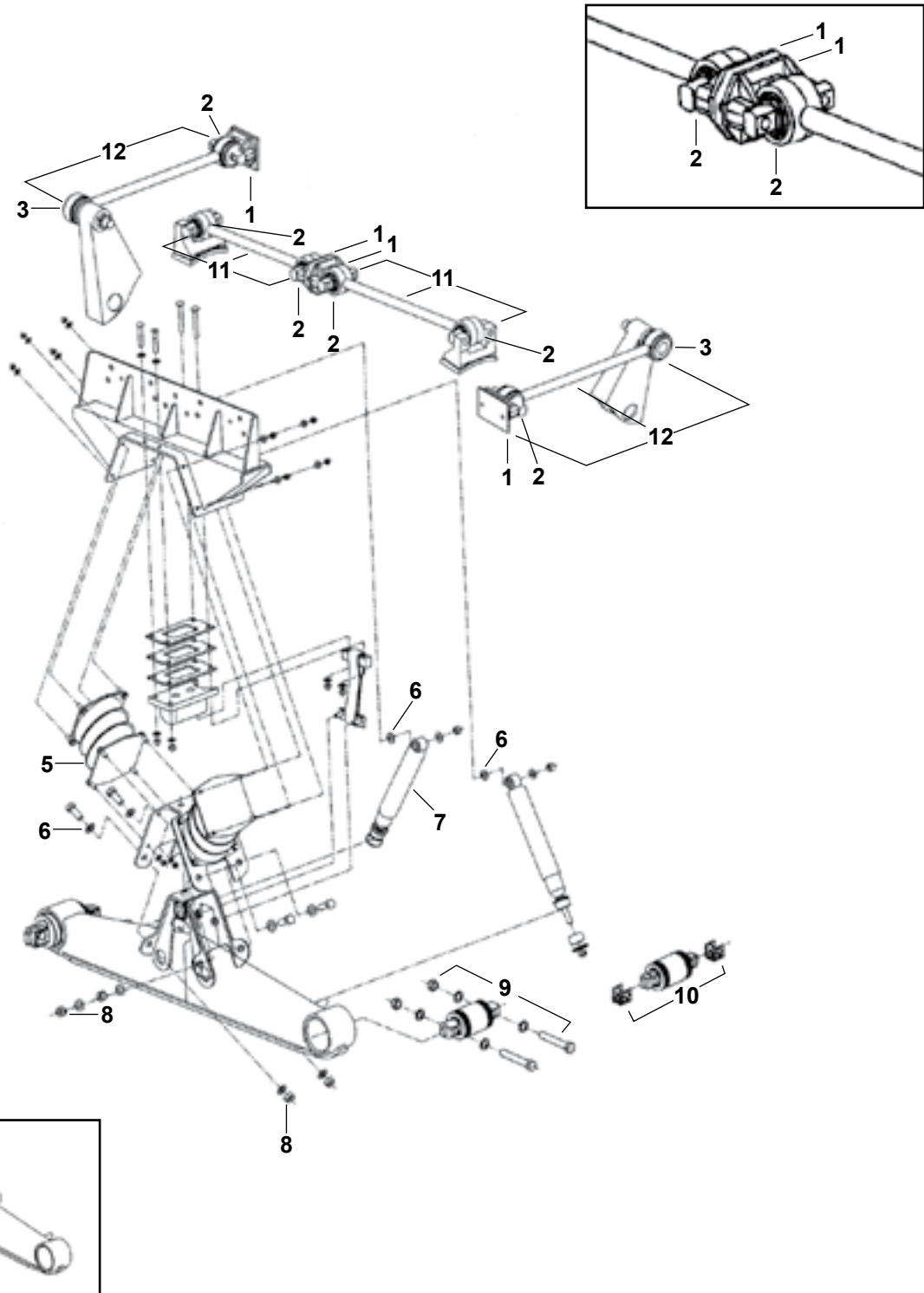



# HENDRICKSON HN-402/462

ITEM NUMBER	PART NUMBER	DESCRIPTION
1	E-2634	TORQUE ROD FRAME BRACKET
2	R302226	TORQUE ROD BUSH (RUBBER/STEEL) SAME AS HENDRICKSON 44695 OR 44695000L
3	R302228	TORQUE ROD BUSH (RUBBER/STEEL - TAPERED PIN) SAME AS HENDRICKSON 44697 OR 44697000L
4	E-9603	1/2" WASHER
5	E-11496	BOLSTER SPRING (MUST BE REPLACED IN PAIRS)
6	E-2545	3/4" WASHER
7	M83112	SHOCK ABSORBER
8	E-4347	3/4"-10 UNC-2B LOCKNUT
9	E-9325	BAR PIN BUSHING KIT, NON-SHIM TYPE
10	R309326	BAR PIN BUSHING KIT, SHIM TYPE
11	E-13989	TORQUE ROD ASSY - INCLUDES ITEM 2 (2) & TORQUE ROD (NOT SOLD SEPARATELY)
12	E-13988	TRANSVERSE ROD ASSY - INCLUDES ITEM 2 & 3 (1 OF EACH) & TRANSVERSE ROD (NOT SOLD SEPARATELY)



# REYCO 21B

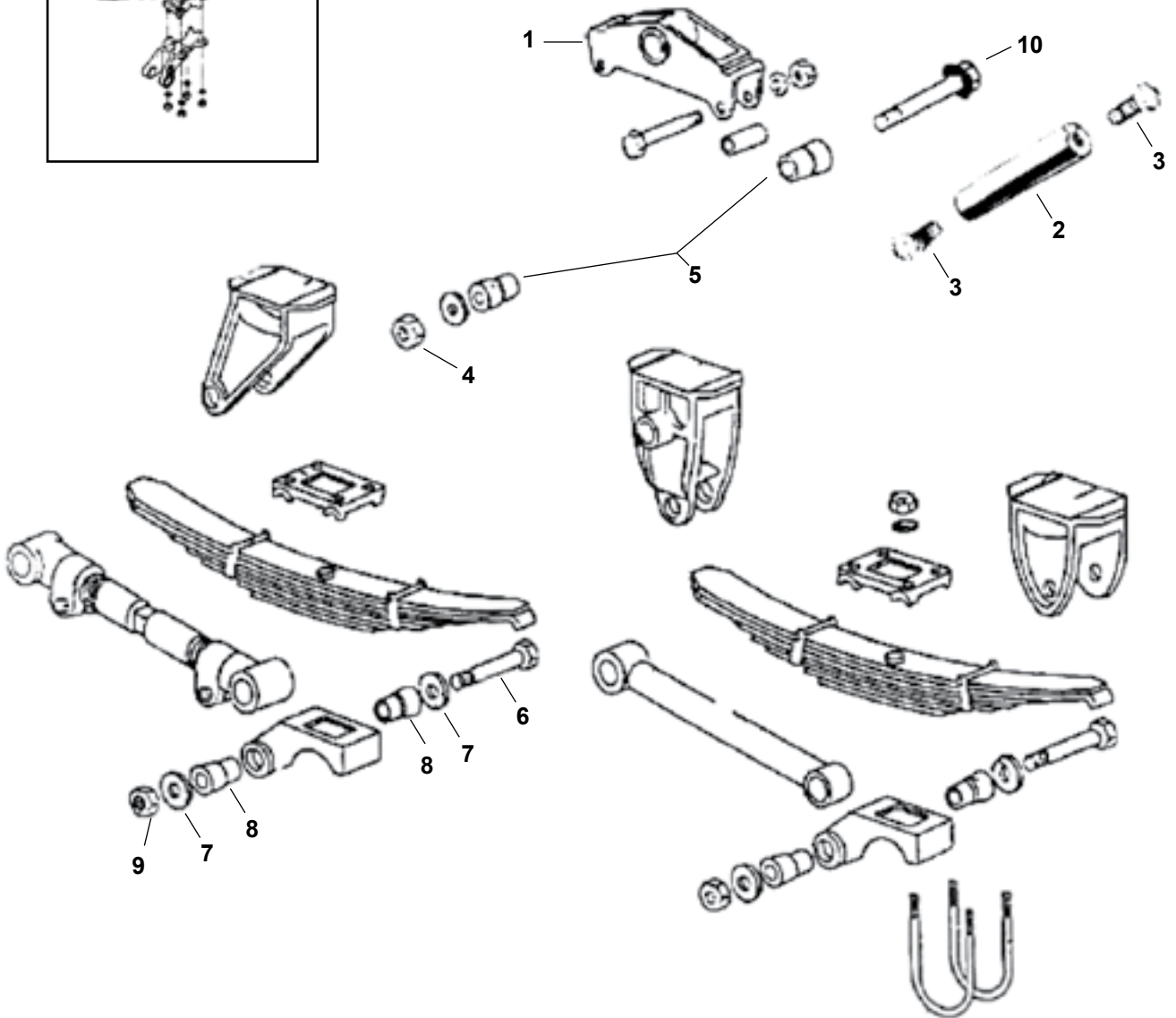
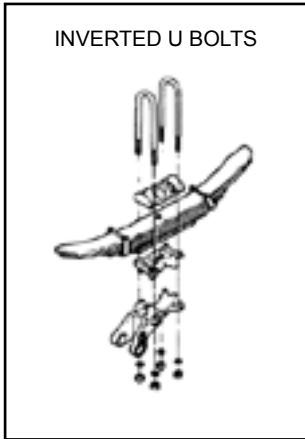

# REYCO 21B

ITEM NUMBER	PART NUMBER	DESCRIPTION
1	E-2846A	EQUALISER
2	E-3972	EQUALISER SHAFT, 1" THREADED HOLES
3	E-1987	LOCK SCREW, 2-1/2" X 3/4"
4	E-937	LOCK NUT, 1"X14 TPI
5	E-1159	BUSH
6	E-1166	BOLT
7	E-907	WASHER
8	E-1160	BUSH
9	E-937	NUT, 1"X14 TPI
10	E-1987	BOLT

KIT	E-3976	BUSH & BOLT ASSY, INCLUDES KEY Nos 2, 3, 4 & 5
-----	--------	--



# REYCO 102W

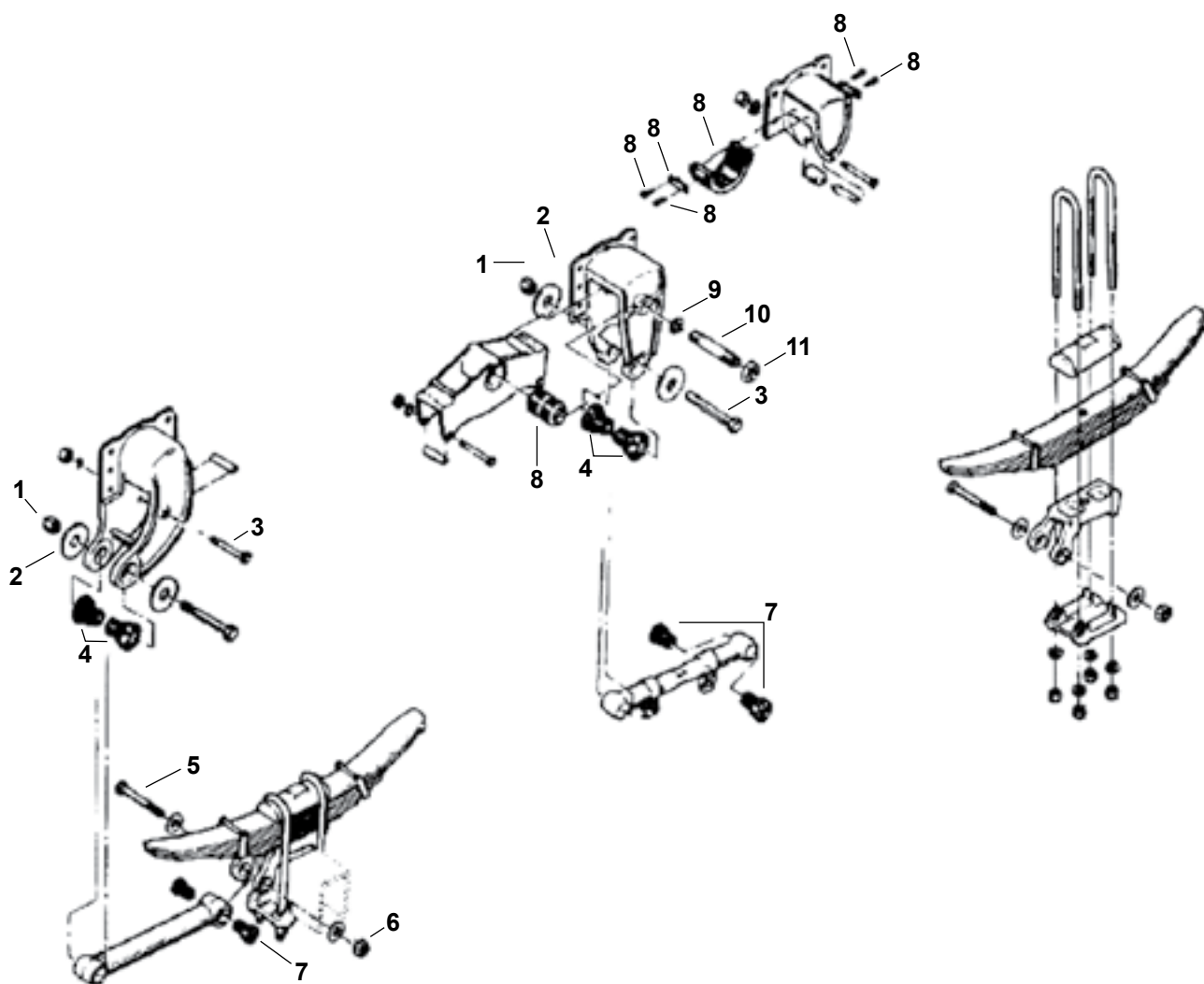

ITEM NUMBER	PART NUMBER	DESCRIPTION
1	E-937	NUT
2	E-905	WASHER
3	E-1166	BOLT
4	E-10057	BUSH
5	E-901	BOLT & NUT ASSEMBLY (102W)
5	E-900	BOLT (102)
6	E-4421	NUT (102)
7	E-1980	BUSH (102W)
7	E-1982	BUSH (102)
8	E-2867A	WEAR PAD KIT

# REYCO TRANSPRO

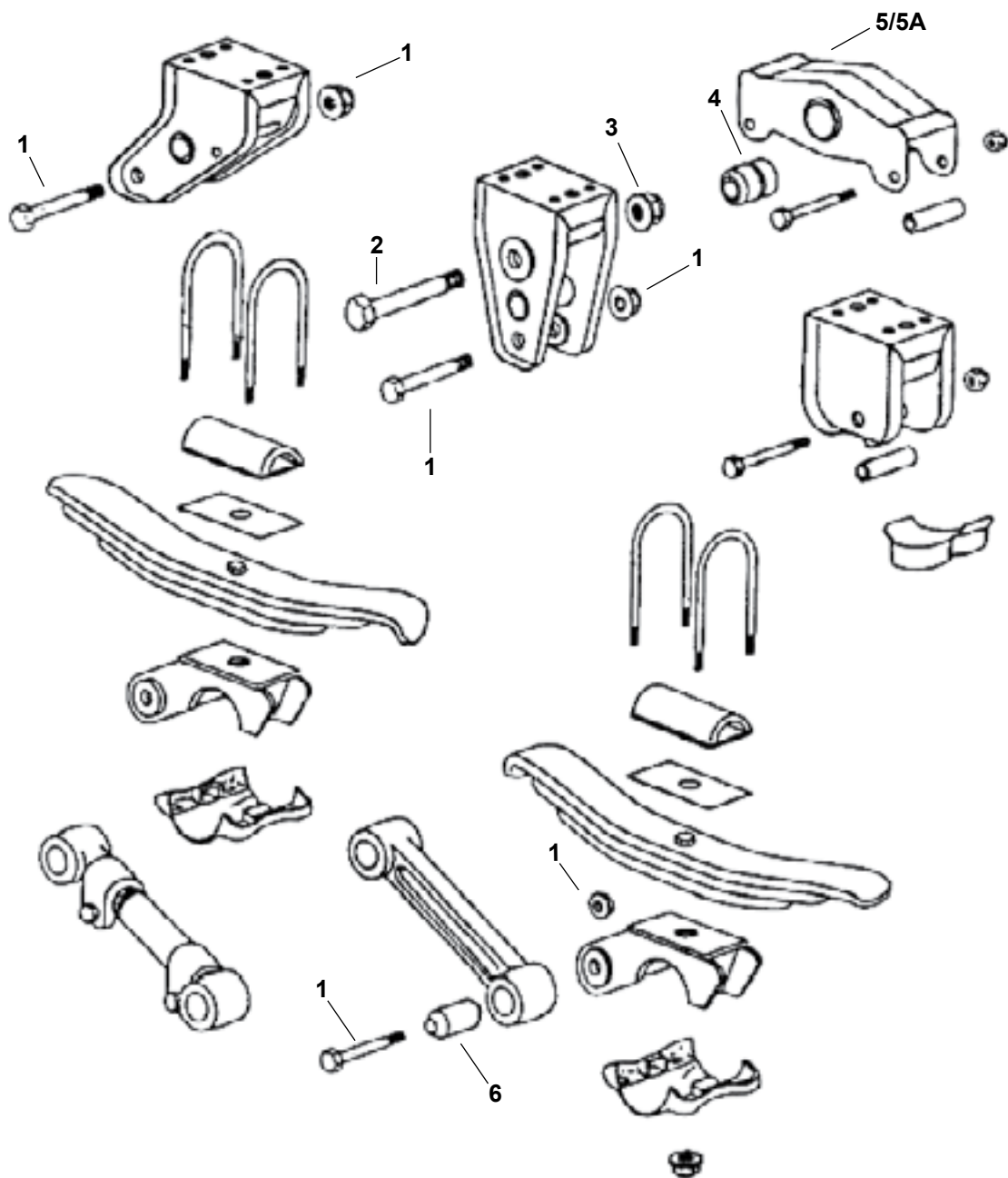

ITEM NUMBER	PART NUMBER	DESCRIPTION
1	E-901	BOLT & NUT ASSEMBLY
2	E-900	BOLT
3	E-4421	LOCK NUT
4	E-4827	BUSH
5	E-4813	EQUALISER (FABRICATED)
5A	E-10250	EQUALISER (CAST)
6	E-1980	BUSH

# VOLVO "T-RIDE" SUSPENSION

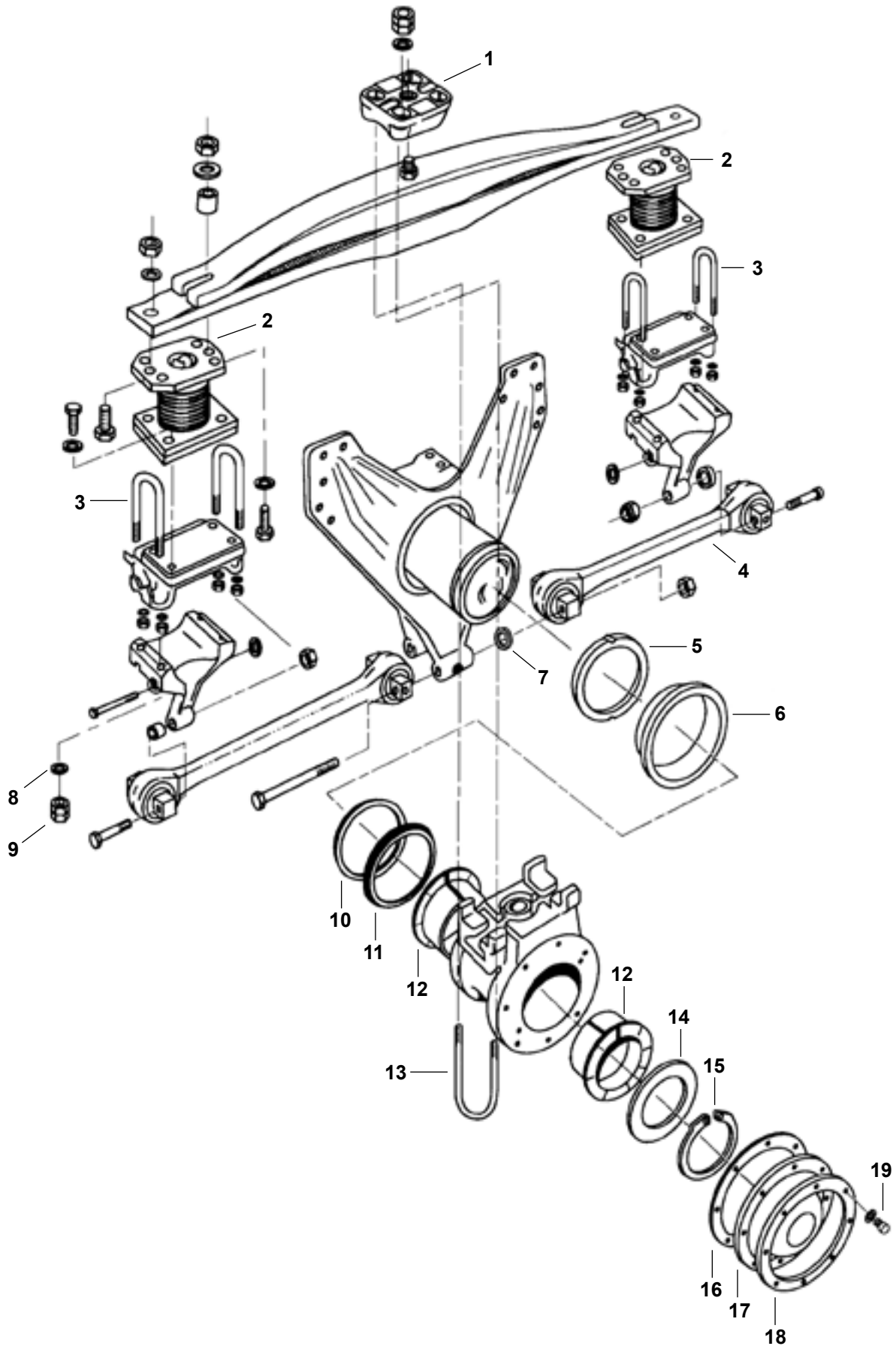

# VOLVO "T-RIDE" SUSPENSION

ITEM NUMBER	PART NUMBER	DESCRIPTION
1	E-8850	TOP PLATE
2	E-8851	RUBBER LOAD SPRING
3	E-UB8151-10	U-BOLT ASSEMBLY, RD. BEND, 3/4"-16 THD. X 3" WIDE X 10" LONG
3	E-UB8151-12	U BOLT ASSEMBLY, RD. BEND, 3/4"-16 THD. X 3" WIDE X 12" LONG
4	E-8853	RIGID TORQUE ARM, BAR TYPE
4	E-8853A	RIDIG TORQUE ARM, TUBE TYPE
5	E-8830	THRUST WASHER
6	E-8834	WEAR RING
7	E-8844	TORQUE ARM SPACER WASHER
8	E-2545	WASHER
9	E-3001	U-BOLT HI-NUT
10	E-8835	SEALING RING
11	E-8836	SEALING RING
12	E-8833	TRUNNION BUSHING
13	E-UB8142-06	U-BOLT ASSEMBLY, RD. BEND, 5/8"-18 THD. X 4 1/8" WIDE X 6" LONG
14	E-8831	THRUST WASHER
15	E-8832	LOCK RING
16	E-8837	GASKET
17	E-8838	TRUNNION HUB CAP
18	E-8839	HUB CAP RING
19	E-8840	HUB CAP SCREW



# ACCESSORIES

## CAM SPRING BRAKE



EUCLID PART NUMBER	MODEL NUMBER	PUSH ROD THREAD SIZE
E-BC2424C	2424	5/8"-18
E-BC2430C	2430	5/8"-18
E-BC3030C	3030	5/8"-18
E-BC3636C	3636	5/8"-18

## COILED AIR HOSE



EUCLID PART NUMBER	COIL LGTH	TUBE OD	END FITTINGS		PIG TAIL LENGTH	
			TRACTOR	TRAILER	TRACTOR	TRAILER
E-10744	15 ft.	1/2"	1/2"	1/2"	12"	12"
E-10746	15 ft.	1/2"	1/2"	1/2"	40"	12"

Includes one red and blue coil assembly. Meets SAE J844 specifications.

## GLADHANDS & SEALS



EUCLID PART NUMBER	DESCRIPTION
E-9107-PL	Service gladhand
E-9108-PL	Emergency gladhand
E-9110	Rubber gladhand seal
E-9111	Rubber gladhand seal with excluder flaps

## AIR BRAKE SERVICE TOOLS

### UNIVERSAL BRAKE SHOE GAUGE



#### **ANCHOR PIN GAUGE**

Go/No-Go guage for all Meritor & Fruehauf standard and quick change shoes.



#### **BRAKE SHOE IDENTIFICATION**

Helps determine if a brake shoe is made by Fruehauf or Meritor.



#### **E-3863A TOOL**

Can also be used to check the stretch or wedge brake shoes. For detailed information, see instruction sheet included with each tool.



#### **WEB ALIGNMENT GAUGE**

Checks straightness of shoe web (exception Eaton shoes).



#### **STRETCH GAUGE**

Checks stretch of all 16 1/2" Eaton, Fruehauf and Meritor shoes.



# ACCESSORIES

## BRAKE SHOE ANCHOR PIN PRESS



EUCLID PART NUMBER	APPLICATION INFORMATION
E-2654	A heavy-duty press that easily removes rusted and corroded brake shoe anchor pins without damage to the brake shoe spider. Removes pins up to 1-1/4" diameter. Use with E-6064 set to remove or install ball joints. Also used to remove brake shoe anchor pins and U-joints.

## WHEEL BEARING LOCK-NUT WRENCHES

### EUCLID E-1597A HEAVY DUTY SPINDLE NUT WRENCH

One wrench used for both



E-04075  
Hub Cap



E-2550  
Spindle Nut

- For Fruehauf "pro-par" spindle nuts and hub caps.
- New design is made of high strength heavy 5/32" gauge steel to resist rounding out, splitting and twisting.
- 8 point, 4-13/16" across flats, 2-7/8" deep. 3/4 square drive opening allows for the use of a torque wrench and extensions.
- Replaces Fruehauf acc-005963-900

### EUCLID E-2644 - AXLE SPINDLE SERVICE TOOLS

Universal outside thread chaser



- Restores threads to their original condition. Eliminates the need for expensive thread cutting equipment.
- Operation: tighten the tool slightly on the good threads, then back off over the damaged thread area to restore the threads. the aluminium alloy V pad will not damage the threads.
- Capacity from 1-1/4" to 5" od.
- Complete with 6 discs - threads per inch 4, 5, 6, 7, 7-1/2, 8, 9, 10, 11, 11-1/2, 12, 14, 16, 18, 20 and 24.

### EUCLID E-9436 - BRAKE DRUM DOLLY

Allows person to easily move, transport and replace tractor/trailer brake drums.



- For class 7 and 8 tractor/trailer brakes.
- Handles 15" and 16-1/2" drums
- 5" height adjustment
- 37" to 55" telescoping handle
- Ball bearing wheels
- Pneumatic tyres
- Rugged steel construction
- Replaces: otc no. 5017



# ACCESSORIES

## SUSPENSION SERVICE TOOLS

### EUCLID E-2652 TORQUE ARM BUSHING TOOL

IMAGE CURRENTLY  
UNAVAILABLE

- For Euclid Torque Arms.
- Tool for installing E-934, E-1980 and #-1061 torque arm bushings in Euclid Torque Arms.
- Tapered counter bore automatically centres bushing for perfect alignment and compression.

### EUCLID E-9575 BEAM END BUSHING INSTALLATION TOOL



- Replaces Hendrickson S-21307.
- For installing tri-functional bushings used in Hendrickson T, HT, Intraax and HLM suspensions with an impact wrench.
- Does not include bushing.

## FRONT END SERVICE TOOLS

### EUCLID E-6066 BALL JOINT SEPARATOR



- 15/16" fork spread, 16" long.
- Ball joint separator is designed solely to remove ball joints from spindle support arms without damaging other components.

### EUCLID E-6067 MULTI-PURPOSE SEPARATOR



- 7/16" fork spread, 11 5/8" long.
- This tool can be used to remove camber adjustment sleeves on ford 4 x 2 and 4 x 4 light trucks where the camber is adjustable. it can also be used as a pitman arm wedge for light duty trucks as well as a tie rod separator for medium and heavy duty trucks.



# ACCESSORIES

## TRUCK WHEEL BEARING LOCK-NUT WRENCH ASSORTMENTS

### 6 PT. WRENCH ASSORTMENT - PART NUMBER E-7651

WHEEL BEARING LOCK-NUT WRENCHES WITH FREE DISPLAY BOARD (BOARD SIZE 24" WIDE x 32" HIGH).

INCLUDED WITH DISPLAY BOARD ARE ONE EACH OF THE 21 WRENCHES LISTED WHICH ARE ALSO SOLD SEPARATELY.

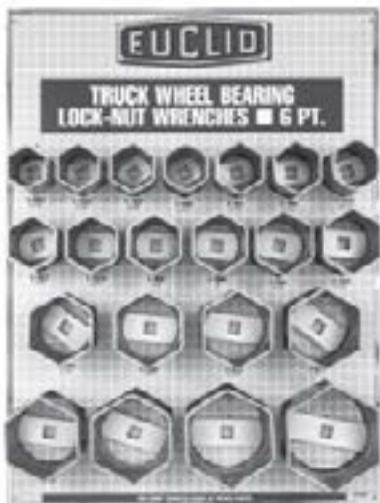

Display board only  
PART NUMBER E-7652

EUCLID PART NUMBER	OPENING SIZE	EUCLID PART NUMBER	OPENING SIZE	EUCLID PART NUMBER	OPENING SIZE
E-1901	2-3/32"	E-1922	2-5/8"	E-1926	3-3/4"
E-1920	2-1/4"	E-1923	2-3/4"	E-1912	3-7/8"
E-1902	2-3/8"	E-1932	2-7/8"	E-1914	4"
E-1936 <sup>1</sup>	2-3/8"	E-1906	3"	E-1915	4-1/8"
E-1921	2-1/2"	E-1934	3-1/8"	E-1916	4-3/8"
E-1904	2-9/16"	E-1908	3-1/4"	E-1918	4-7/8"
E-1928 <sup>1</sup>	2-9/16"	E-1910	3-1/2"	E-3371	5-1/4"

### 8 PT. WRENCH ASSORTMENT - PART NUMBER E-7653

WHEEL BEARING LOCK-NUT WRENCHES WITH FREE DISPLAY BOARD (BOARD SIZE 24" WIDE x 32" HIGH).

INCLUDED WITH DISPLAY BOARD ARE ONE EACH OF THE 20 WRENCHES LISTED WHICH ARE ALSO SOLD SEPARATELY.



Display board only  
PART NUMBER E-7654

EUCLID PART NUMBER	OPENING SIZE	EUCLID PART NUMBER	OPENING SIZE	EUCLID PART NUMBER	OPENING SIZE
E-1903	2-3/8"	E-1935	3-1/8"	E-1913	3-7/8"
E-1929 <sup>2</sup>	2-1/2"	E-1909	3-1/4"	E-3372	4-1/8"
E-1937	2-3/4"	E-1924	3-3/8"	E-1917	4-3/8"
E-1905	2-9/16"	E-1911	3-1/2"	E-6137	4-1/2"
E-1933	2-7/8"	E-1931 <sup>2</sup>	3-1/2"	E-1597A	4-13/16"
E-1930 <sup>2</sup>	2-7/8"	E-1925	3-3/4"	E-1919	4-7/8"
E-1907	3"	E-1927	3-13/16"		

<sup>1</sup> Fits special 'rounded' hex nuts found on Dana axles of some Ford trucks.

<sup>2</sup> Tubular spanner wrenches.

# ADDITIONAL INFORMATION

## MERITOR BRAKE SHOE KITS

### SPECIFICATIONS

FMSI + Shoe Type	Application	Size	Standard Grade	Premium Grade
1308, Q	Meritor Steer "Q"	15" X 4" Q	KSMA2121308Q	KSMA3121308Q
1308, T	Meritor Steer "T" Brake	15" X 4" T	KSMA2121308T	
4311, E	Eaton Drive	16.5" X 7"	KSMA2124311E	KSMA3124311E
4514, Q	Meritor Steer "Q"	16.5" X 6" Q	KSMA2124514Q	KSMA3124514Q
4515, F(Q)	Fruehauf/ SAF/ TMC	16.5" X 7" Q	KSMA2124515F3	KSMA3124515F3
4515, F(P)	Fruehauf/ SAF/ TMC	16.5" X 7" P	KSMA2124515F	
4515, P	Meritor Drive "P"	16.5" X 7" P	PKSMA2124515P	PKSMA3124515P
4515, PSS	Meritor Drive "P" Severe Service - Smooth	16.5" X 7" P	PKSMA2124515PSS	KSMA3124515PSS
4515, Q	Meritor Drive "Q"	16.5" X 7" Q	KSMA2124515Q	KSMA3124515Q
4524, Q	Meritor Steer "Q"	16.5" X 5" Q	KSMA2124524Q	KSMA3124524Q
4702, QP	Meritor Steer "Q Plus"	15" X 4" Q Plus	KSMA2124702QP	KSMA3124702QP
4707, QP	Meritor Drive "Q Plus"	16.5" X 7" Q Plus	KSMA2124707QP	KSMA3124707QP
4709, ESI	Eaton ES1 Drive	16.5" X 7"	KSMA2124709E1	KSMA3124709E1
4709, ESII	Eaton ESII Drive	16.5" X 7"	KSMA2124709E2	
4710, QP	Meritor Steer /Trailer "Q Plus"	15" X 8 5/8" Q Plus	KSMA2124710QP	KSMA3124710QP
4711, QP	Hendrickson Intraax	16.5" X 8 5/8" Q Plus	KSMA2124711QP	KSMA3124711QP
4715, QP	Meritor Steer "Q Plus"	16.5" X 6" Q Plus	KSMA2124715QP	KSMA3124715QP
4719, ESII	Eaton Drive Brake ESII	16.5" X 5"	KSMA2124719R	KSMA3124719R
4720, QP	Meritor Steer "Q Plus"	16.5" X 5" Q Plus	KSMA2124720QP	KSMA3124720QP
4725	Spicer Steer Brake	16.5" X 6"	KSMA2124725R	KSMA3124725R
BC/36/1, B95	BPW Brake 95 BC/36/1	420mm X 180mm	MKSMG2ABC36/95	
BC/36/1, NG	BPW New Gen BC36/1	420mm X 180mm	MKSMG2ABC36/NG	
BC/37/1, B95	BPW Brake 95 BC/37/1	420mm X 200mm	MKSMG2ABC37	



PKSMA2124515PSS - Meritor Drive "P" Severe Service - Smooth (4515, PSS)

# ADDITIONAL INFORMATION

## EUCLID BRAKE SHOE KITS

### SPECIFICATIONS

FMSI + Shoe Type	Application	Size	Standard Grade	Premium Grade
1308, Q	Meritor Steer "Q"	15" X 4" Q	EKSMG1A1308Q	EKSMG2A1308Q
1308, T	Meritor Steer "T" Brake	15" X 4" T	EKSMG1A1308T	EKSMG2A1308T
4311, E	Eaton Drive	16.5" X 7"	EKSMG1A4311E	EKSMG2A4311E
4514, Q	Meritor Steer "Q"	16.5" X 6" Q	EKSMG1A4514Q	EKSMG2A4514Q
4515, F(Q)	Fruehauf/ SAF/ TMC	16.5" X 7" Q	EKSMG1A4515F3	EKSMG2A4515F3
4515, F(P)	Fruehauf/ SAF/ TMC	16.5" X 7" P	EKSMG1A4515F	EKSMG2A4515F
4515, P	Meritor Drive "P"	16.5" X 7" P	EKSMG1A4515PHD	EKSMG2A4515PHD
4515, PSS	Meritor Drive "P" Severe Service - Smooth	16.5" X 7" P	EKSMG1A4515PSS	EKSMG2A4515PSS
4515, PSSK	Meritor Drive "P" Severe Service - Knurled	16.5" X 7" P	EKSMG1A4515PSSK	EKSMG2A4515PSSK
4515, Q	Meritor Drive "Q"	16.5" X 7" Q	EKSMG1A4515Q	EKSMG2A4515Q
4524, Q	Meritor Steer "Q"	16.5" X 5" Q	EKSMG1A4524Q	EKSMG2A4524Q
4692	Dana	12 1/4" X 7.5"	EKSMG1A4692	EKSMG2A4692
4702, QP	Meritor Steer "Q Plus"	15" X 4" Q Plus	EKSMG1A4702QP	EKSMG2A4702QP
4705, QP	Meritor Steer "Q Plus"	15" X 7" Q Plus	EKSMG1A4705QP	EKSMG2A4705QP
4707, QP	Meritor Drive "Q Plus"	16.5" X 7" Q Plus	EKSMG1A4707QP	EKSMG2A4707QP
4709, ESI	Eaton ES1 Drive	16.5" X 7"	EKSMG1A4709E1	EKSMG2A4709E1
4709, ESII	Eaton ESII Drive	16.5" X 7"	EKSMG1A4709E2	EKSMG2A4709E2
4710, QP	Meritor Steer /Trailer "Q Plus"	15" X 8 5/8" Q Plus	EKSMG1A4710QP	EKSMG2A4710QP
4711, QP	Hendrickson Intraax	16.5" X 8 5/8" Q Plus	EKSMG1A4711QP	EKSMG2A4711QP
4715, QP	Meritor Steer "Q Plus"	16.5" X 6" Q Plus	EKSMG1A4715QP	EKSMG2A4715QP
4719, ESII	Eaton Drive Brake ESII	16.5" X 5"	EKSMG1A4719R	EKSMG2A4719R
4720, QP	Meritor Steer "Q Plus"	16.5" X 5" Q Plus	EKSMG1A4720QP	EKSMG2A4720QP
4725	Spicer Steer Brake	16.5" X 6"	EKSMG1A4725R	EKSMG2A4725R
BC/36/1, B95	BPW Brake 95 BC/36/1	420mm X 180mm	EKSMG1ABC36/95	EKSMG2ABC36/95
BC/36/1, NG	BPW New Gen BC36/1	420mm X 180mm	EKSMG1ABC36/NG	EKSMG2ABC36/NG
BC/37/1, B95	BPW Brake 95 BC/37/1	420mm X 200mm	EKSMG1ABC37	EKSMG2ABC37



EKSMG1A4515PSS - Meritor Drive "P" Severe Service - Smooth (4515, PSS)



# ADDITIONAL INFORMATION

## STEELLITE X30 BRAKE DRUMS

### SPECIFICATIONS

Brake Size	Meritor Part No.	Hayes Equiv.	Overall Depth	Braking Surface Width	Pilot Diameter	Bolt Circle	Bolt Hole No.	Bolt Hole Size	Meritor Weight	Hayes Drum Back No.	Hayes Drum Band No.	GAWR
15x4	53-123512-002	90089BK	8.640	4.920	8.780	11.250	10	1.281	62	91294	91028	13200
15x4	53-123542-002	89870BK	8.890	4.570	8.780	11.250	10	1.281	63	91026	91028	13200
15x4	53-123567-002	91137BK	8.640	4.920	8.780	11.250	10	0.937	63	91136	91028	13200
15x4	53-123568-002	90660BK	8.890	4.570	8.780	11.250	10	0.937	64	91029	91028	13200
15x5	53-123598-002	90174B	9.530	5.810	8.780	11.250	10	1.281	70	90173	87311	12000
15x5	53-123600-002	N/A	9.530	5.810	8.780	11.250	10	0.937	70	N/A	N/A	12000
15x7	53-123591-002	90148B	10.220	7.420	8.780	11.250	10	0.937	80	91293	87132	20000
15x7	53-123592-002	87128B	10.220	7.420	8.531	11.250	10	0.812	80	91008	87132	20000
15x7	53-123593-002	87442B	10.220	7.420	9.002	11.250	10	0.812	80	87443	87132	20000
15x8.62	53-123601-002	91725B	11.440	9.280	8.780	11.250	10	1.030	91	91724	91480	20000
16.5x5	53-123589-002	90600B	9.220	5.820	8.780	11.250	10	1.281	79	90599	87369	14600
16.5x5	53-123590-002	87707B	9.220	5.820	8.531	11.250	10	1.281	79	87709	87369	14600
16.5x5	53-123605-002	88739B	8.590	5.870	8.531	11.250	10	1.281	78	88435	87369	14600
16.5x5	53-123606-002	90137B	8.590	5.870	8.780	11.250	10	1.281	77	91507	87369	14600
16.5x5	53-123627-002	N/A	8.790	6.070	8.780	11.250	10	1.281	77	N/A	N/A	14600
16.5x6	53-123607-002	91049B	9.620	6.680	8.780	11.250	10	0.937	88	91052	87298	20000
16.5x6	53-123608-002	91265B	9.620	6.680	8.780	11.250	10	1.281	87	91264	87298	20000
16.5x7	53-123537-002	89996B	10.380	7.670	8.780	11.250	10	0.937	94	91538	87105	23000
16.5x7	53-123564-002	87101B	10.380	7.670	8.531	11.250	10	0.812	94	91611	87105	23000
16.5x7	53-123565-002	87156B	10.380	7.670	9.002	11.250	10	0.812	93	87157	87105	23000
16.5x8	53-123535-002	91792B	10.960	8.620	8.780	11.250	10	0.937	95	91793	91795	23000
16.5x8.62	53-123544-002	N/A	11.040	8.950	8.780	11.250	10	0.937	103	N/A	N/A	23000
16.5x8.62	53-123580-002	87615B	12.150	9.380	8.531	11.250	10	0.812	106	91611	87618	23000
16.5x8.62	53-123581-002	90486B	12.150	9.380	8.780	11.250	10	0.937	106	91538	87618	23000
16.5x8.62	53-123596-002	89467B	11.870	9.100	8.531	11.250	10	0.812	104	91611	87618	13200
16.5x8.62	53-123597-002	90434B	11.870	9.100	8.780	11.250	10	0.937	104	91538	87618	23000
16.5x7	53-123582-002	87295B	10.040	7.270	8.531	11.250	10	0.812	90	91611	87298	23000
16.5x7	53-123583-002	89877B	10.040	7.270	8.780	11.250	10	0.937	89	91538	87298	23000



# ADDITIONAL INFORMATION

## U-BOLT

### SPECIFICATIONS

Part Number	Description
E-UB5165-14	U BOLT 14" X 5" X 7/8"
E-UB5161-18	U BOLT ASSY 18" X 3" X 7/8"
E-UB5165-18	U BOLT ASSY 18" X 5" X 7/8"
E-UB5161-14	U BOLT ASSY 14" X 3" X 7/8"
E-8123AU	U BOLT AC6T 12" X 5.23" X 2.75"
E-8124AU	U BOLT 11" X 3.55" X 2.95"
E-8127AU	U BOLT AC6S 11.9" X 4.07" X 3"
E-UB8151-18	U BOLT ASSY 18" X 3" X 3/4"
E-UB8165-076	U BOLT ASSY 7.75" X 5" X 3"
E-UB8165-10	U BOLT ASSY 10" X 5" X 7/8"

## UNI ROD KITS

### SPECIFICATIONS

Part Number	Description
KIT5118	KIT UNI ROD
E-3180	KIT UNI ROD
KIT5116	KIT UNI ROD

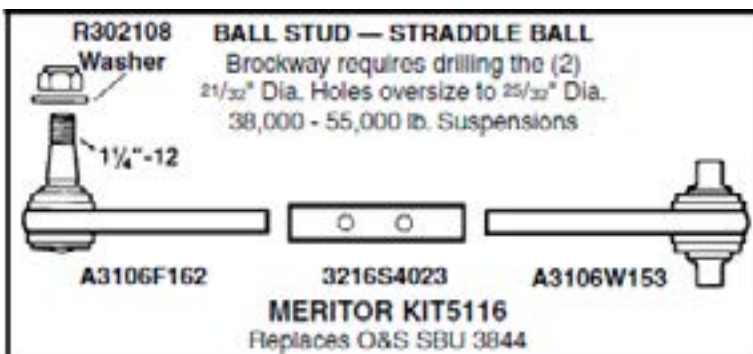
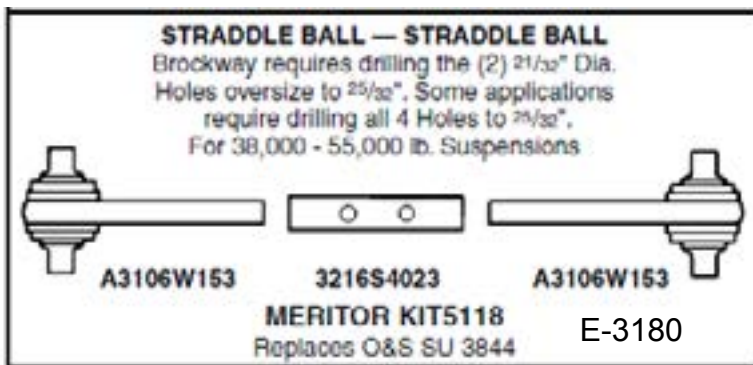

# ADDITIONAL INFORMATION

## UNI-ROD UNIVERSAL BALL JOINT TORQUE ARMS ASSEMBLY INSTRUCTIONS

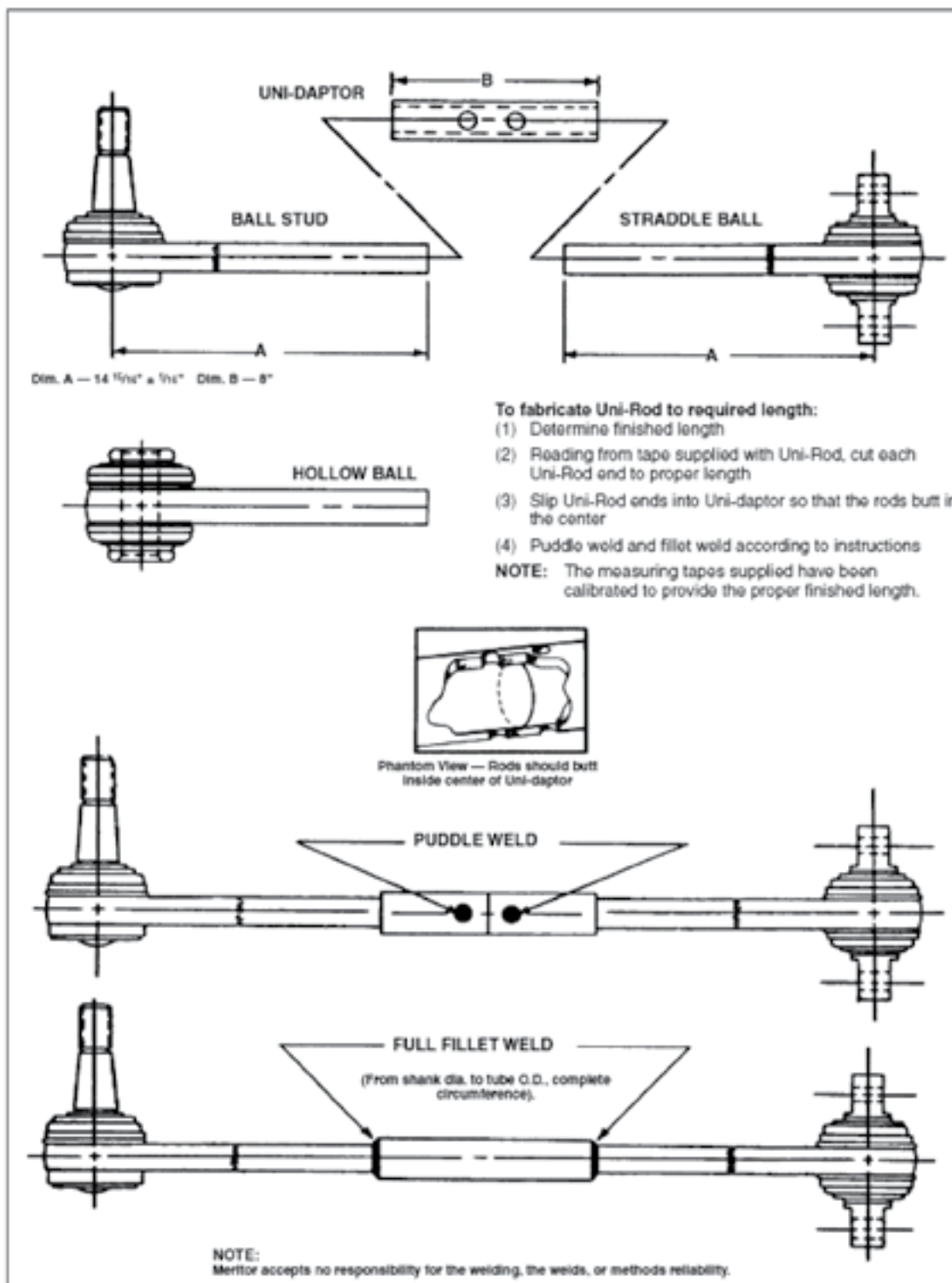



# ADDITIONAL INFORMATION

## WHEEL BEARINGS - SETS

MERITOR PART NUMBER	INDUSTRY PART NUMBER	DESCRIPTION
MERSET401	SET401	WHL END BRG SET
MERSET402	SET402	WHL END BRG SET
MERSET403	SET403	WHL END BRG SET
MERSET404	SET404	WHL END BRG SET
MERSET405	SET405	WHL END BRG SET
MERSET406	SET406	WHL END BRG SET
MERSET407	SET407	WHL END BRG SET
MERSET408	SET408	WHL END BRG SET
MERSET409	SET409	WHL END BRG SET
MERSET410	SET410	WHL END BRG SET
MERSET411	SET411	WHL END BRG SET
MERSET412	SET412	WHL END BRG SET
MERSET413	SET413	WHL END BRG SET
MERSET414	SET414	WHL END BRG SET
MERSET415	SET415	WHL END BRG SET
MERSET416	SET416	WHL END BRG SET

MERITOR PART NUMBER	INDUSTRY PART NUMBER	DESCRIPTION
MERSET417	SET417	WHL END BRG SET
MERSET418	SET418	WHL END BRG SET
MERSET419	SET419	WHL END BRG SET
MERSET420	SET420	WHL END BRG SET
MERSET421	SET421	WHL END BRG SET
MERSET422	SET422	WHL END BRG SET
MERSET423	SET423	WHL END BRG SET
MERSET424	SET424	WHL END BRG SET
MERSET425	SET425	WHL END BRG SET
MERSET426	SET426	WHL END BRG SET
MERSET501	---	WHL END BRG SET
MERSET502	---	WHL END BRG SET
MERSET503	---	WHL END BRG SET
MERSET504	---	WHL END BRG SET
MERSET505	---	WHL END BRG SET

## WHEEL BEARINGS - INDIVIDUAL

MERITOR PART NUMBER	INDUSTRY PART NUMBER	DESCRIPTION
MER28682	28682	WHL END CONE
MER3782	3782	WHL END CONE
MER39590	39590	WHL END CONE
MER45280	45280	WHL END CONE
MER45284	45284	WHL END CONE
MER45291	45291	WHL END CONE
MER47679	47679	WHL END CONE
MER47686	47686	WHL END CONE
MER47890	47890	WHL END CONE
MER555S	555S	WHL END CONE
MER567	567	WHL END CONE
MER580	580	WHL END CONE
MER582	582	WHL END CONE
MER594A	594A	WHL END CONE
MER598A	598A	WHL END CONE
MER6461A	6461A	WHL END CONE
MERH715334	H715334	WHL END CONE
MERH715343	H715343	WHL END CONE
MERH715345	H715345	WHL END CONE
MERHM212047	HM212047	WHL END CONE
MERHM212049	HM212049	WHL END CONE
MER663	663	WHL END CONE
MERHM218248	HM218248	WHL END CONE
MERHM516449A	HM516449A	WHL END CONE
MERHM516449C	HM516449C	WHL END CONE
MERHM518445	HM518445	WHL END CONE
MER28622	28622	WHL END BRG CUP

MERITOR PART NUMBER	INDUSTRY PART NUMBER	DESCRIPTION
MER3720	3720	WHL END BRG CUP
MER39520	39520	WHL END BRG CUP
MER45220	45220	WHL END BRG CUP
MER47620	47620	WHL END BRG CUP
MER47820	47820	WHL END BRG CUP
MER552A	552A	WHL END BRG CUP
MER563	563	WHL END BRG CUP
MER572	572	WHL END BRG CUP
MER592A	592A	WHL END BRG CUP
MER6420	6420	WHL END BRG CUP
MER653	653	WHL END BRG CUP
MERH715311	H715311	WHL END BRG CUP
MERHM212011	HM212011	WHL END BRG CUP
MERHM218210	HM281210	WHL END BRG CUP
MERHM516410	HM516410	WHL END BRG CUP
MERHM518410	HM518410	WHL END BRG CUP
MER32215	32215	CUP & CONE
MER32216	32216	CUP & CONE
MER32217	32217	CUP & CONE
MER32222M	32222M	CUP & CONE
MER32310	32310	CUP & CONE
MER32314	32314	CUP & CONE
MER33116	33116	CUP & CONE
MER33118	33118	CUP & CONE
MER33213	33213	CUP & CONE
MER33215	33215	CUP & CONE
MER33217	33217	CUP & CONE



# ADDITIONAL INFORMATION

## WHEEL BEARING KITS

MERITOR PART NUMBER	APPLICATION	BEARING CONE	BEARING CUP
MERSET401	MERITOR / EATON	MER580	MER572
MERSET402	MERITOR / DANA / MACK	MER582	MER572
MERSET403	MERITOR / EATON	MER594A	MER592A
MERSET404	EATON	MER598A	MER592A
MERSET405	AUSTRALIAN TANNER 15" DANA / SPICER / HENDRICKSON D21 & K21 15" & 20" FREIGHTER A19H 15" HAULMARK / DANA D21 & K21 15" & 20" ROCKWELL / MERITOR TK, TKD 20" RUBERY OWEN EARLY T SERIES SPIDER 20" / T SERIES STUD 20" STANDARD FORGE EARLY TYPE 15" AND 20"	MER663	MER653
MERSET406	MERITOR / DANA / SPICER / EATON	MER3782	MER3720
MERSET407	DANA	MER28682	MER28622
MERSET408	MERITOR / DANA	MER39590	MER39520
MERSET409	MERITOR	MER45280	MER45220
MERSET410	MERITOR	MER45284	MER45220
MERSET411	MERITOR	MER47686	MER47620
MERSET412	MERITOR / DANA / SPICER / EATON	MERHM212047	MERHM212011
MERSET413	AUSTRALIAN TANNER ATN20" / ATN 15" COLRAIN TQ20" DANA / SPICER / HENDRICKSON EARLY TYPE 15" & 20" DANA / SPICER / HENDRICKSON D21 & K21 15" & 20" DANA / SPICER / HENDRICKSON D22 TAPER SPINDLE & K22 15" & 20" FREIGHTER EATON E34 15" FREIGHTER A19H 15" FREIGHTER EATON JE07-L & JE501-L 20" FREIGHTER - INGERSOLL A22H, F22H 15" & 20" HAULMARK - ROCKWELL MERITOR TL RUBERY OWEN HAULMARK - DANA D21 & K21 15" & 20" HAULMARK - DANA D22 ROCKWELL MERITOR TN 20" HOLLAND TAPER SPINDLE 20" KIC SUDISA TN20" KRUEGER - DANA D22 ROCKWELL / MERITOR TK, TKD 20" ROCKWELL / MERITOR ARN, ATN, RN, TN, TQ 15" & 20" ROCKWELL / MERITOR ATL, TKL, TL, TLD, RL 15" & 20" ROR TN 15" & 20" RUBERY OWEN EARLY T SERIES SPIDER 20" RUBERY OWEN LATE U SERIES SPIDER 15" & 20" STANDARD FORGE EARLY TYPE 15" & 20" TRAIL QUIP ATN 15" & 20" YORK 782, 784, 20" & 783 15" DANA / SPICER I-100, I-120, I-140 & W15 / DANA / SPICER I-150S EATON EFA-12F3, 12F4, 13F4 MERITOR FG941	MERHM212049	MERHM212011
MERSET414	AUSTRALIAN TANNER ATN20" COLRAIN TQ20" DANA / SPICER / HENDRICKSON D22 TAPER SPINDLE & K22 15" & 20" FREIGHTER EATON JE07-L & JE501-L 20" FREIGHTER - INGERSOLL A22H, F22H 15" & 20" HAULMARK - DANA D22 HOLLAND TAPER SPINDLE 20" KIC SUDISA TN20" KRUEGER - DANA D22 MOSS METRIC AND LOW LOADER ROCKWELL / MERITOR TN20" ROCKWELL / MERITOR ARN, ATN, RN, TQ 15" & 20" ROR TN 15" & 20" / ROR TM 20" TRAIL QUIP ATN 15" & 20" YORK 782, 784, 20" & 783 15" / YORK 160 20" / YORK 160 LOW LOADER	MERHM218248	MERHM218210
MERSET415	DANA / SPICER / HENDRICKSON P22 PARALLEL SPINDLE 15" & 20" FRUEHAUF PROPAR 15" & 20" HOLLAND PROPAR 20" PARALLEL SPINDLE YORK HEAVY DUTY OUTBACK 20"	MERHM518445	MERHM518410
MERSET416	MERITOR / DANA	MER45291	MER45220
MERSET417	MERITOR	MER47890	MER47820
MERSET418	MERITOR	MERH715334	MERH715311
MERSET419	MERITOR	MERH715343	MERH715311
MERSET420	MERITOR	MERH715345	MERH715311



# ADDITIONAL INFORMATION

## WHEEL BEARING KITS cont'd

MERITOR PART NUMBER	APPLICATION	BEARING CONE	BEARING CUP
MERSET421	MACK	MERHM516449A	MERHM516410
MERSET422	MACK	MERHM516449C	MERHM516410
MERSET423	MERITOR FL941, MFS73	MER6461A	MER6420
MERSET424	MERITOR FL941, MFS73	MER555S	MER552A
MERSET425	MERITOR / DANA	MER567	MER563
MERSET426	MACK	MER47679	MER47620
		INNER	OUTER
MERSET501	BPW OLD GEN EHZ8000 15"	MER33215*	MER32310*
MERSET502	BPW OLD GEN EHZ9000-9008-9010 15"	MER33217*	MER33213*
MERSET503	LIGHTWEIGHT H&R KH9000 20" NR900015" & ECO	MER33116*	MER32310*
MERSET504	NEW GEN NH9000 H91000 H&R KH 10000 20" & ECO	MER33118*	MER33213*
MERSET505	H, KH, NH9000 + ECO ECO MAX	MER33118*	MER32310*

## WHEEL SEALS

### SPECIFICATIONS - STANDARD WHEEL SEALS

MERITOR STANDARD	APPLICATION	SKF®/CR CLASSIC	NATIONAL® RED	STEMCO® VOYAGER	DANA®
MER0143	Trailer	46305	370025A	373-0143	—
MER0173	Drive	47697	370003A	393-0173	—
MER0136	Steer	35066	370001A	383-0136	—
MER0123	Trailer	42623	370065A	373-0123	—
MER0112	Drive	38780	370023A	393-0112	—
MER0164	Steer	43764	370048A	383-0164	—
MER0113	Trailer	40136	370036A	373-0113	—
MER0103	Drive	45099	370022A	393-0103	—
MER0104	Drive	42672	370031A	393-0104	—

### SPECIFICATIONS - PREMIUM WHEEL SEALS

MERITOR PREMIUM	APPLICATION	SKF/CR PLUS XL LONGLIFE	NATIONAL "GOLD" 5-STAR	STEMCO DISCOVER	DANA OUTRUNNER
MER0243	Trailer	46300	380025A	373-0243	859
MER0273	Drive	47692 / 47691 (ABS)	380003A	393-0273	861
MER0236	Steer	35058	380001A	383-0236	847
MER0223	Trailer	42627	380065A	373-0223	851
MER0212	Drive	38776	380023A	393-0212	849
MER0264	Steer	43761	380048A	383-0264	863
MER0213	Trailer	40129	380036A	373-0213	850
MER0203	Drive	45093	380022A	393-0203	856
MER0204	Drive	42673	380031A	393-0204	852



# PARTS CROSS REFERENCE

## ATAP

PART NUMBER	MERITOR PART NUMBER
593	593
653	653
50108	50108
85000	85000
85013	85013
85030	85030
85310	85310
85323	85323
85900	85900
89436	89436
89440	89440
21228930	21228930
90054007	E-11494
592A	592A
665A	665A
745400P	MER0123
747400P	MER0113
755400P	MER0143
BD200	03-122963-002
BD733	03-122222-002
BD737	85-120586-002
BD743	3219T176A
BD803	03-122971-002
BP1101	E-1020
BP1101U	E-7432
BP1102	E-1999A
BP1109	E-1966
BP1110	E-1159
BP1112A	E-4827
BP1113	21222609
BP1165	E-2830
BP1195	E-4813
BP1195C	E-10250
BP1196	E-2846A
BP1213	E-1967
BP1214	E-1968
BP1215	E-1969
BP1216	E-3972
BP1218	E-1987
BP1225	E-4830
BP1231	E-2001
BP1301	E-927
BP1301U	E-7433
BP1302	E-934
BP1308	E-1980
BP1309	E-1982
BP1310	E-10057
BP1311	E-1160

PART NUMBER	MERITOR PART NUMBER
BP1312	E-1061
BP1317	E-5275
BP1318	R302226
BP1319	R302228
BP1320	E-10303
BP1321	E-4669
BP1401	E-1018
BP1403	E-901
BP1408	E-1074
BP1411	E-905
BP1412	E-4421
BP1413	E-900
BP1414	E-907
BP1415	E-1166
BP1432	21222326
BP1433	21223928
BP1438	21224663
BP1439	21222234
BP1440	21222230PK10
BP1441	21222231PK10
BP1442	99527003
BP1443	99527004PK50
	99527004PK5
BP1444	99513008
BP1445	99513007
BP1446	21222243
BP1448	21222221
BP1449	21222287
BP1450	21222690
BP1451	21224386
BP1452	21222247
BP1453	21224664
BP1455	21230041
BP1456	21228664
BP1457	21228663
BP1458	21226663PK12
BP1459	21222923PK50
BP1461	21216189PK4
BP1462	99544001PK10
BP1463	99526002PK50
BP1464	99510003PK20
BP1465	21228171PK4
BP1805	FS9373
BP1806	FS9270
BP1807	FS9265
BP1808P	FS9466
BP1813P	FS9422
BP1816P	21208082

PART NUMBER	MERITOR PART NUMBER
BP1827	FS8091
BP1828P	FS8709
BP1829	21222442
BP1836	FS9622
	FS9617
	FS9618
BP1837	FS9625
BP1850	21222239FS
BP1866	FS9616
BP1871	21229214
BP2001	E-2099
BP2002	E-2100
BP2003	E-1425A
BP2003-4CT	E-4737A
BP2004	E-1424A
BP2005	E-685
BP2006	E-684
BP2007	E-1563
BP2008	E-1564
BP2011	E-2449A
BP2012	E-2450A
BP2013	E-1773C
BP2014	E-1774C
BP2017	E-2693
BP2018	E-2694
BP2019	E-2800
BP2020	E-2799
BP2021	E-1776
BP2022	E-1775
BP2025	E-1411
BP2026	E-1410
BP2027	E-2443B
BP2028	E-2444B
BP2029	E-1394
BP2030	E-1393
BP2031	W-1148C
BP2032	W-1147C
BP2033	E-9661
BP2034	E-9662
BP2035	21219257S
BP2036	21219258S
BP2045	E-4890
BP2046	E-4891
BP2047	E-5511
BP2048	E-5510
BP2055P	E-4739
BP2089	E-3861
BP2090	E-3862

Indicative list only. For part numbers not found above, please contact Meritor Customer Service on (03) 8353 6000



# PARTS CROSS REFERENCE

## ATAP cont'd

PART NUMBER	MERITOR PART NUMBER
BP2101	E-535
BP2102	E-1571
BP2103	E-1577A
BP2104	E-661
BP2107	E-2102
BP2109	E-2695
BP2110	E-1385
BP2112	E-11867
BP2113	E-11866
BP2116	E-5509
BP2117	E-5508
BP2201 + BP2202	E-943
BP2203	E-1567
BP2204	1205G761
BP2208	E-759
BP2208B	E-807
BP2209	1225L1208
BP2209B	E-667
BP2211	E-2690A
BP2212	1225M897
BP2215	21209990PK10
BP2216	E-2517
BP2217	E-11449
BP3002	E-603
BP3003-4	E-4594
BP3005ROR	15213430
BP3005SQ	E-1318A
BP3006	E-2361
BP3007	E-1314
BP3008	15224821
BP3013	E-2365
BP3100	E-1569
BP3101	E-656
BP3102	E-580
BP3103	1229Q771
BP3104	1229M559
BP3105	E-2409
BP3106	E-1565
BP3107	1229Z1118
BP3112	E-564
BP3113	E-1272
BP3114	E-2380
BP3115	E-1271
BP3116	A1205P1602
BP3117	1229X3118
BP3118	E-3991
BP3119	E-2407

PART NUMBER	MERITOR PART NUMBER
BP3120	E-2408
BP3121	E-2406
BP3122	E-1416
BP3123	A1205V1556
BP3133	E-1416A
BP3134	E-1113
BP3135	R627005
BP3136	E-1781
BP3137	E-3234
BP3138	E-2405
BP3145	E-2717
BP3149	E-5482
BP3199	1259M1131
	E-1112A
BP3200	1259Q251
BP3202	E-1106
BP3204	1199E1695
BP3205	1229X1116
BP3206	1225U827
BP3207	E-1893
BP3207B	1225B496
BP3212	E-541
BP3213	E-919
BP3214	E-563
BP3216	E-2390
BP3217	E-2391
BP3218	E-2392
BP3222	E-1808
BP3223	1229D2942
BP3300	E-502
BP3305	1259N274
BP3307	E-2773
BP3308	E-1403
BP3312	E-3711
BP3330	KIT9000
	E-1816SHD
BP3332	E-8466AU
BP3332S	E-8465AU
BP3333	E-2769HD
	KIT8000HD
BP3335	R507008
BP3338	E-1887AHD
BP3339	E-4709ES-N
BP3340	E-10244
BP3343	E-3374HD
BP3344	E-2403HD
BP3345	E-2402HD
BP3348	E-3373HD

PART NUMBER	MERITOR PART NUMBER
BP3350	1229Q2851
BP3351	E-2720
BP3400	E-1582
BP3401	E-539
	E-5478
BP3402	E-3227
BP3403	E-2177
BP3403S	E-2177
BP3404	E-2215
BP3404S	E-781
BP3405	E-586
BP3418	3105B210
BP3419	E-2208
BP3419A	E-1406
BP3420	E-596A
BP3421	E-595
BP3421K	E-2217A
BP3425	E-527
BP3432	E-2395
BP3433	E-2396
BP3435	E-500
	E-2176
BP3436	E-501
BP3437	E-773
BP3451	E-1880B
BP3452	E-747
BP3453	E-2767
BP3454	2258W803
BP3456	21210215PK10
BP3462	E-2785
BP3463	E-1418
BP3464	E-1428A
BP3465	E-1400
BP3466	R567004
BP3471	2258V256
BP3474	E-1583
BP3475	E-1581
BP3602	E-5540
BP3603	E-2522
BP3604	E-3995
BP3607	E-3997
BP3608	1205C2005
BP3611	E-1137
BP3612	E-1136
BP3613	2258H580
BP3616	E-1261
BP3623	E-2484
BP3626	E-5531

Indicative list only. For part numbers not found above, please contact Meritor Customer Service on (03) 8353 6000



# PARTS CROSS REFERENCE

## ATAP cont'd

PART NUMBER	MERITOR PART NUMBER
BP3635	E-5539
BP3650	A2297V2882
BP3651	E-5532
BP3656	E-5532
BP3652	2297N2874
BP3657	E-1458
BP3664	E-5541
BP4001	E-576
BP4002	E-2550
BP4006	E-572
BP4007	E-573
BP4007T	E-2237
BP4008	E-540
BP4009	E-1561
BP4010	E-620
BP4012	E-1251
BP4013	E-1252
BP4014	E-2128
BP4020	E-04075
BP4021	E-05500
BP4022	E-04000
BP4024	E-03009
BP4029G	E-975
BP4052	E-1559
BP4059	21210819
	21020818
	21205571
BP5019BLH	E-2762
BP5019BRH	E-2763
BP5020	E-612SBK
BP5021	E-1574SBK
BP5023	E-940SBK
BP5025	E-2458SBK
BP5028B	E-2091
BP5030	E-2685
BP5030WR	EKSMG2A4515F
	KSMA2124515F
	SMG2A4515F
BP5032	E-2241
BP5032WR	PKSMA2124515P
	EKSMG2A4515PSSK
	EKSMG2A4515PHD
	EKSMG2A4515PSS
	SMG2A4515PSS
	SMA2124515P
	SMA2124515PSS
SMG2A4515PHD	
BP5036	E-2819

PART NUMBER	MERITOR PART NUMBER
BP5036R	EKSMG2A4311E
	SMA2124311E
	SMG2A4311E
BP5041R	KSMA2124515F3
	EKSMG2A4515F3
	SMA2124515F3
	SMG2A4515F3
BP5042	R4515
BP5042R	KSMA2124707QP
	KSMA2124515Q
	EKSMG2A4707QP
	EKSMG2A4515Q
	SMA2124515Q
SMG2A4515Q	
BP5043	E-1398
BP5048	E-2684
BP5049R	A3722D82
BP5051	E-1777
BP5052	EKSMG2A4692
	KSMA2124692FC2
	SMA2124692FC2
	SMG2A4692
BP5052HD	KMG14591S
BP5053	E-10270
BP5100	E-886
BP5100P	E-3775
BP6001	R004956A
BP6002	E-7775
BP6051	E-5571A
BP6058	E-5040A
BP7001	KIT8048
BP7001	E-3520A
BP7002	E-2104
BP7003	E-3975
BP7004	E-2101
BP7011	KIT1129
BP7012	E-10754
BP7013	E-10755
BP7017	E-1580
BP7018	E-10730A
BP7022	E-6121
BP7024	E-3771
BP7025	E-3768
BP7026	E-6122
BP7027	E-3303
BP7028	SMG2A1308T
BP7029	E-1308Q
BP7031	E-3421A

PART NUMBER	MERITOR PART NUMBER
BP7032	2258E1123
BP7033	SMG2A1308Q
BP7034	E-3876
BP7035	2258G579
BP7037	E-937
BP7064	E-2474
BP7065	4711XT
BP7065R	SMG2A4711QP
BP7074	R4707
BP7074R	SMA2124707QP
	SMG2A4707QP
BP7075R	SMG2A4709E1
	SMA2124709E2
	SMG2A4709E2
BP7083	E-10271
BP7085	E-10197
	E-1019
BP7086	E-10198
BP7091	E-11456
BP7092	E-3304
BP7093	E-10854
BP7094	E-9062
BP7095	E-11453
BP7096	A3222P2200
BP7099	E-5477
BP7103	E-2475
BP7123	E-10729A
BP7132	E-9063
BP7183	1205G761
BP7184	E-9772
BP7185	E-9771
BP9004	KIT9078
	E-2086B
BP9005	E-1357A
BP9006	E-2122
BP9006R	E-2090
BP9007	E-2088AHD
BP9008	KIT970
BP9009	E-2287
	R615008
BP9010	E-2696A
BP9015	E-6078
BP9020	E-9791HD
BP9021	E-11450
BP9022	E-11897
BP9024	AXL122
HH506310	HH506310
HH506348	HH506348

Indicative list only. For part numbers not found above, please contact Meritor Customer Service on (03) 8353 6000



# PARTS CROSS REFERENCE

## ATAP cont'd

PART NUMBER	MERITOR PART NUMBER
SET405	MERSET405
SET413	MERSET413

PART NUMBER	MERITOR PART NUMBER
SET414	MERSET414

PART NUMBER	MERITOR PART NUMBER
SET415	MERSET415

## CONTITECH

PART NUMBER	MERITOR PART NUMBER
4157N P05	21222442

## DANA SPICER

PART NUMBER	MERITOR PART NUMBER
12-391	E-540
12-392	E-573
12-393	E-572
12-394	E-2237
12-397	E-1252
12-398	E-1251
12-399	E-2128
12-400	E-2550
12-402	E-1561
12-404	E-576
12-405	E-620
15-527	1259M1131
15-537	E-2390
15-542	1259N274
16-561	1225U827
16-563	E-1893
17-580	E-1424A
17-581	E-1425A
17-582	E-684
17-583	E-685
17-618	E-4891
17-619	E-4890
17-623	E-3227
17-628	E-2444B
17-629	E-2443B
17-632	E-2450A
17-633	E-2449A
17-684	E-1410

PART NUMBER	MERITOR PART NUMBER
17-685	E-1411
19-853	E-1880B
19-857	E-2101
19-860	E-2767
19-862	2258V256
19-863	E-1583
20-881	E-747
21-895	E-2685
27-1191	E-2517
27-1194	E-1577A
27-1195	E-2102
27-1197	E-2361
27-1198	E-1571
27-1208	E-1314
28-1232	E-759
28-1233	1225L1208
28-1236	E-943
28-1237	E-1567
28-1238	E-2690A
28-1241	E-2408
28-1252	E-2380
28-1253	E1271
28-1257	E-661
29-1267	E-1272
29-1269	E-1416
29-1274	E-3991
29-1275	E-2406
29-1301	1229Z1118

PART NUMBER	MERITOR PART NUMBER
29-1302	E-1569
29-1307	1229Q771
29-1308	E-580
29-1309	E-564
29-1310	E-656
29-1312	1229X3118
29-1326	E-2409
30-1357	E-2104
30-1358	E-1318A
30-1362	E-603
30-1385	E-2365
31-1401	E-4737A
31-1405	E-4739
32-1425	E-2177
32-1426	E-781
32-1430	E-1582
32-1445	E-2395
32-1446	E-2396
33-1478	E-886
34-1525	1229X1116
34-1526	E-527
34-1527	E-2392
34-1529	E-539
34-1531	E-1581
34-1532	3105B210
34-1533	1199E1695
35-1581	E-2391
52-1301	E-5571A

Indicative list only. For part numbers not found above, please contact Meritor Customer Service on (03) 8353 6000



# PARTS CROSS REFERENCE

## EATON

PART NUMBER	MERITOR PART NUMBER
39074	E-595
39075	E-596A
70306	E-1776
70307	E-1775
70326	E-1418
125011	E-1565
125012	E-1569
10000087	E-2800
10000088	E-2799
2-806380	E-5482
B-1214	1229X1116
B-1216	E-580
B-1552	1199E1695
B-1661	E-527
B-1736-1	E-1416
B-2010	E-1400

PART NUMBER	MERITOR PART NUMBER
B-2011	E-2208
B-2012-2A	E-1398
B-2022	E-1893
B-2028A	E-535
B-2076	1259M1131
125034	E-2693
125035	E-2694
804365	E-2819
819706	E-10271
1000406	E-2475
1002262	E-2695
1002279	E-3991
1003817	E-1428A
1008412	E-2690A
B-1216	E-580
B-1552	1199E1695

PART NUMBER	MERITOR PART NUMBER
B-1661	E-527
B-1662-1	A1205V1556
B-1688A	E-886
B-1691-1	E-1425A
B-1691-2	E-1424A
B-1705	E-3711
B-1716	1229Z1118
B-2138	E-2091
B-2460-37	E-1394
B-2460-38	E-1393
B-866	R567004
F-1529	E-540
F-1530	E-572
F-1531	E-573
X-115	E-576
X-4212	E-3975

## FIRESTONE

PART NUMBER	MERITOR PART NUMBER
7074	21222442
7370	2122239FS
8091	FS8091
8608	21229214
9270	FS9270
9297	FS9373
9373	FS9373

PART NUMBER	MERITOR PART NUMBER
9616	FS9616
9622	FS9622
9625	FS9625
1T15MM-9 9265	FS9265
1T15MP-7 7074	21222442
1T15MT-8 9297	FS9373
1T15MT-8 9373	FS9373

PART NUMBER	MERITOR PART NUMBER
1T15VM-3.5 9270	FS9270
1T19FC-5 8091	FS8091
1T19FC-6 8091	FS8091
W01-358-9616	FS9616
W01-M58-8608	21229214

## FLEETLINE

PART NUMBER	MERITOR PART NUMBER
FL08.296	E-05500
FL10.353	E-2091
FL10.367	E-1574SBK
FL12.391	E-540
FL12.392	E-573
FL12.393	E-572
FL12.394	E-2237
FL12.397	E-1252
FL12.398	E-1251
FL12.399	E-2128
FL12.400	E-2550
FL12.402	E-1561
FL12.404	E-576
FL12.405	E-620

PART NUMBER	MERITOR PART NUMBER
FL14A	KIT9000
FL15.527	1259M1131
FL15.540	E-1403
FL15.542	1259N274
FL15-537	E-2390
FL16.561	1225U827
FL16.563	E-1893
FL17.580	E-1424A
FL17.581	E-1425A
FL17.582	E-684
FL17.583	E-685
FL17.618	E-4891
FL17.619	E-4890
FL17.622	E-2100

PART NUMBER	MERITOR PART NUMBER
FL17.623	E-2099
FL17.628	E-2444B
FL17.629	E-2443B
FL17.632	E-2450A
FL17.633	E-2449A
FL17.634	E-2694
FL17.635	E-2693
FL17.682	E-1393
FL17.683	E-1394
FL17.684	E-1410
FL17.685	E-1411
FL17-582	E-684
FL17-583	E-685
FL17-620	E-1564

Indicative list only. For part numbers not found above, please contact Meritor Customer Service on (03) 8353 6000





# PARTS CROSS REFERENCE

## FLEETLINE cont'd

PART NUMBER	MERITOR PART NUMBER
FL17-621	E-1563
FL17-622	E-2100
FL17-623	E-2099
FL17-628	E-2444B
FL17-629	E-2443B
FL17-632	E-2450A

PART NUMBER	MERITOR PART NUMBER
FL17-633	E-2449A
FL17-634	E-2694
FL17-635	E-2693
FL17-682	E-1393
FL17-683	E-1394
FL18-726	E-2799

PART NUMBER	MERITOR PART NUMBER
FL18-727	E-2800
FL18-738	E-1775
FL18-739	E-1776
FL18-811	E-1776
FL19.6855A	21210215PK10
FL19.853	E-1880B

## GOODYEAR

PART NUMBER	MERITOR PART NUMBER
1R11-106	21222442
1R11-221	FS9622
1R11-222	FS9625
1R12-375	FS9265

PART NUMBER	MERITOR PART NUMBER
1R12-402	FS9373
1R12-403	FS9373
1R13-119	FS9270
1R14-093	FS8091

PART NUMBER	MERITOR PART NUMBER
1R14-171	FS8091
1R14-721	2122239FS
1S12-029	FS9373
1S12-030	FS9373

## HENDRICKSON

PART NUMBER	MERITOR PART NUMBER
44695	R302226
44695000L	R302226
44697000L	R302228
47691	E-5275
57122-002	FS9373
57256-00C	E-9395
58849-002	FS9373
A-20811	1229Q2851
C-20010	FS9270

PART NUMBER	MERITOR PART NUMBER
C-20124	FS9265
C-20559	FS9270
C-21208	FS9270
C-21784	FS8091
C-24636-1L	E-11866
C-24636-1R	E-11867
C-3558	E-6121
S-20901	FS8091
S-20924	E-10755

PART NUMBER	MERITOR PART NUMBER
S-20925	E-10754
S-21208	FS9270
S-22885	E-2717
S-22898	E-11449
S-24679	E-10730A
S-24691	E-10729A
S-26348	E-11897

## IVECO

PART NUMBER	MERITOR PART NUMBER
BRB2052R	E-2100
FL18-727	E-2800
FL18-738	E-1775
FL18-738	E-1775
FL18-739	E-1776
FL18-739	E-1776
FL18-811	E-1776
FL18-811	E-1776
FL19.6855A	21210215PK10
FL19.6855A	21210215PK10
FL19.853	E-1880B
IT1101P	E-7432

PART NUMBER	MERITOR PART NUMBER
IT1110	E-1159
IT1116L	E-1425A
IT1116R	E-1424A
IT1165	E-2830
IT1195	E-4813
IT1196	E-2846A
IT12.391	E-540
IT12.392	E-573
IT12.393	E-572
IT12.394	E-2237
IT12.397	E-1252
IT12.398	E-1251

PART NUMBER	MERITOR PART NUMBER
IT12.400	E-2550
IT12.402	E-1561
IT12.404	E-576
IT12.405	E-620
IT1301	E-927
IT1301P	E-7433
IT1308	E-1980
IT1309	E-1982
IT1310N	E-10057
IT1311	E-1160
IT1401HD	E-1018
IT2025	E-1411

Indicative list only. For part numbers not found above, please contact Meritor Customer Service on (03) 8353 6000



# PARTS CROSS REFERENCE

## IVECO cont'd

PART NUMBER	MERITOR PART NUMBER
IT2026	E-1410
IT2027	21219257S
IT2028	21219258S
IT2029	E-2693
IT2030	E-2694
IT20-881	E-747
IT21.889	E-2241
IT21.895	E-2685
IT21.898	R4515
IT21.922E	E-2819
IT21.929	E-1580
IT27.1194	E-1577A
IT27.1195	E-2102
IT27.1196	E-2695
IT27.1197	E-2361
	15224821
IT27.1198	E-1571
IT27.1200	E-535
IT27.1208	E-1314
IT28.1232	E-759
IT28.1233	1225L1208
IT28.1234	E-667
IT28.1236	E-943
IT28.1237	E-1567
IT28.1238	E-2690A
IT28.1240	E-2407
IT28.1241	E-2408
IT28.1252	E-661
IT28.1253	E1271

PART NUMBER	MERITOR PART NUMBER
IT28.1257	E-661
IT29.1266	E-1416A
IT29.1267	E-1272
IT29.1269	E-1416
IT29.1270	A1205V1556
IT29.1274	E-3991
IT29.1275	E-2406
IT29.1301	1229Z1118
IT29.1302	E-1569
IT29.1303	E-3234
IT29.1307	1229Q771
IT29.1308	E-580
IT29.1309	E-564
IT29.1310	E-656
IT29.1311	1229M559
IT29.1312	1229X3118
IT29.1322	E-1565
IT29.1326	E-2409
IT30.1357	E-2104
IT30.1358	E-1318A
IT30.1362	E-603
IT31.1401	E-4737A
IT31.1405	E-4739
IT32.1425	E-2177
IT32.1426	E-2215
IT32.1427	E-586
IT32.1428	2297T7222
IT32.1428A	E-2215
IT32.1428B	E-586

PART NUMBER	MERITOR PART NUMBER
IT32.1430	E-1582
IT32.1441	E-595
IT32.1442	E-596A
IT32.1445	E-2395
IT32.1446	E-2396
IT3202	E-1106
IT33.1476A	E-886
IT34.1525	1229X1116
IT34.1526	E-527
IT34.1529	E-539
IT34.153	E-3227
IT34.1530	E-3227
IT34.1531	E-1581
IT34.1532	3105B210
IT34.1533	1199E1695
IT3456	21210215PK10
IT35.1581	E-2391
IT43.7036	E-1357A
IT43.7037	KIT970
IT43.7038	E-2122
IT43.7044	E-2088AHD
IT6001	R004956A
IT6002	E-7775
IT6051	E-5571A
IT8.295	E-04075
IT8.296	E-05500
IT8.297	E-04000
ITBD20	03-122222-002
ITBD40	85-120586-002

## REYCO

PART NUMBER	MERITOR PART NUMBER
0650-00	E-4813

PART NUMBER	MERITOR PART NUMBER
0850-00	E-10250

PART NUMBER	MERITOR PART NUMBER
T5427	E-2846A

## WATTS

PART NUMBER	MERITOR PART NUMBER
WT1002	E-2846A
WT1004C	E-4813
	E-10250
WT1005	E-2830
WT1101	E-1020
WT1101U	E-7432
WT1102	E-1999A

PART NUMBER	MERITOR PART NUMBER
WT1110	E-1159
WT1201	E-1019
WT1225	E-4830
WT1231	E-2001
WT1301R	E-927
WT1301U	E-7433
WT1302	E-934

PART NUMBER	MERITOR PART NUMBER
WT1308	E-1980
WT1309	E-1982
WT1310	E-10057
WT1311	E-1160
WT1312	E-1061
WT1401C	E-1018
WT2001	E-2099

Indicative list only. For part numbers not found above, please contact Meritor Customer Service on (03) 8353 6000



# PARTS CROSS REFERENCE

## WATTS cont'd

PART NUMBER	MERITOR PART NUMBER
WT2002	E-2100
WT2003	E-1425A
WT2004	E-1424A
WT2005	E-685
WT2006	E-684
WT2011	E-2449A
WT2012	E-2450A
WT2013	E-1773C
WT2014	E-1774C
WT2017	E-2693
WT2018	E-2694
WT2019	E-2800
WT2020	E-2799
WT2021	E-1776
WT2022	E-1775
WT2025	E-1411
WT2026	E-1410
WT2027	E-2443B
WT2028	E-2444B
WT2029	E-1394
WT2030	E-1393
WT2031	W-1148C
WT2032	W-1147C
WT2033	E-9661
WT2034	E-9662
WT2035	21219257S
WT2036	21219258S
WT2055	E-4737A
WT2055P	E-4739
WT2101	E-535
WT2102	E-1571
WT2103	E-1577A
WT2104	E-661
WT2107	E-2102
WT2201 + WT2202	E-943
WT2203	E-1567
WT2204	1205G761
WT2208	E-759
WT2208B	E-807
WT2211	E-2690A
WT2216	E-2517
WT3002	E-603
WT3003/4	E-4594
WT3005SQ	E-1318A
WT3006	E-2361

PART NUMBER	MERITOR PART NUMBER
WT3007	E-1314
WT3013	E-2365
WT3100	E-1569
WT3101	E-656
WT3102	E-580
WT3103	1229Q771
WT3105	E-2409
WT3106	E-1565
WT3107	1229Z1118
WT3112	E-564
WT3113	E-1272
WT3114	E-2380
WT3115	E1271
WT3117	1229X3118
WT3118	E-3991
WT3119	E-2407
WT3120	E-2408
WT3121	E-2406
WT3122	E-1416
WT3123	A1205V1556
WT3202	E-1106
WT3207	E-1893
WT3212	E-541
WT3213	E-919
WT3214	E-563
WT3216	E-2390
WT3217	E-2391
WT3218	E-2392
WT3300	E-502
WT3305	1259N274
WT3307	E-2773
WT3308	E-1403
WT3330	KIT9000
WT3332	E-8466AU
WT3345	E-1828
WT3400	E-1582
WT3401	E-539
WT3402	E-3227
WT3403	E-2177
WT3404	E-2215
WT3404S	E-781
WT3418	3105B210
WT3419	E-2208
WT3420	E-596A
WT3421	E-595
WT3425	E-527

PART NUMBER	MERITOR PART NUMBER
WT3432	E-2395
WT3433	E-2396
WT3451	E-1880B
WT3452	E-747
WT3453	E-2767
WT3454	2258W803
WT3463	E-1418
WT3464	E-1428A
WT3465	E-1400
WT3466	R567004
WT3471	2258V256
WT3473	E-2101
WT3603	E-2522
WT4001	E-576
WT4002	E-2550
WT4006	E-572
WT4007	E-573
WT4007T	E-2237
WT4008	E-540
WT4009	E-1561
WT4010	E-620
WT4012	E-1251
WT4013	E-1252
WT4014	E-2128
WT4020	E-04075
WT4021	E-05500
WT4024	E-03009
WT5021	E-1574SBK
WT5028	E-2091
WT5030	E-2685
WT5032	E-2241
WT5036	E-2819
WT5042	R4515
WT5043	E-1398
WT5052	EKSMG2A4692
WT5100	E-886
WT6001	R004956A
WT6002	E-7775
WT6051	E-5571A
WT6058	E-5040A
WT6601	85-120586-002
WT6605	03-122222-002
WT9004	KIT9078
WT9005	E-1357A
WT9006	E-2122
WT9007	E-2088AHD

Indicative list only. For part numbers not found above, please contact Meritor Customer Service on (03) 8353 6000









**Meritor Heavy Vehicle Systems**  
50 Calarco Drive  
DERRIMUT VIC 3030  
AUSTRALIA

Phone: (+61 3) 8353 6050  
Fax: (+61 3) 8353 6060  
Email: [cvaau.sales@meritor.com](mailto:cvaau.sales@meritor.com)

[meritorpartsonline.com](http://meritorpartsonline.com)  
[meritor.com](http://meritor.com)